

iPad Kiosk - 01

TABLET-STD-01

Sleekly-designed free standing tablet stands and kioks make it easy to encourage interactivity, present information and engage your customers in any space.



features and benefits:

- State-of-the-art 30mm aluminum tube frame with sturdy internal spigot assembly
- Easy to store and ship
- Quick to set up
- Kit includes: one frame, one dye-sublimated pillowcase graphic, medium monitor mount, tablet holder, and one wheeled molded OCH2 storage case
- Lifetime hardware warranty against manufacturer defects

dimensions:

Hardware	Graphic
<p>Assembled unit: 30" w x 84" h x 23" d 762mm(w) x 2134mm(h) x 584mm(d)</p> <p>Monitor mount: 32" / 30 lbs max</p> <p>Approximate weight (includes graphic): 25 lbs / 11.3 kg</p>	<p>Refer to related graphic template for more information.</p> <p>Visit: www.exhibitors-handbook.com/graphic-templates</p>
Shipping	
<p>Shipping dimensions: 1 OCH2 case: 52" l x 29" w x 15" h 1321mm(l) x 737mm(w) x 381mm(h)</p> <p>Approximate shipping weight (with case): 55 lbs / 24.95 kg</p>	

additional information:

Graphic material:
Dye-sublimated pillowcase fabric

Monitor and tablet not included.

*Tablet holder compatible with 2nd -4th gen. and Air iPad tablets only.



www.display-setup-animations.com

We are continually improving and modifying our product range and reserve the right to vary the specifications without prior notice. All dimensions and weights quoted are approximate and we accept no responsibility for variance. E&OE. See Graphic Templates for graphic bleed specifications.

Parts Included		
Part Label	Qty	Part Code
5/16-18 WING NUT	x9	5_16_18 WING NUT
5/16-18 X 2" STEEL STUD	x9	5_16_18X2 STUD
EXPANDING SPIGOT FOR 30MM TUBE	x9	ES-30
11 3/8" X 13 3/8" TABLET HOLDER (FOR GEN 2 & 3 ONLY)	x1	TABLET-HOLDER
MEDIUM MONITOR BRACKET	x1	MM-MB
BASE FOR STD-01 WITH FC RING	x1	STD-01-BASE
FABRIC GRAPHIC FOR STD-01	x1	STD-01-G
30MM TUBE SECTION	x1	STD-01-T2
30MM TUBE END SECTION	x1	STD-01-T3
30MM TUBE SECTION	x1	STD-01-T4
30MM CURVED TUBE SECTION LEFT	x1	STD-01-T5-L
30MM CURVED TUBE SECTION RIGHT	x1	STD-01-T5-R
30MM TUBE SECTION LEFT	x1	STD-01-T6-L
30MM TUBE SECTION RIGHT	x1	STD-01-T7
30MM CURVED TUBE SECTION WITH PLATE	x1	STD-01-T7
SILVER ANODIZE FINISH 30MM TUBE CLAMP	x2	TC-20

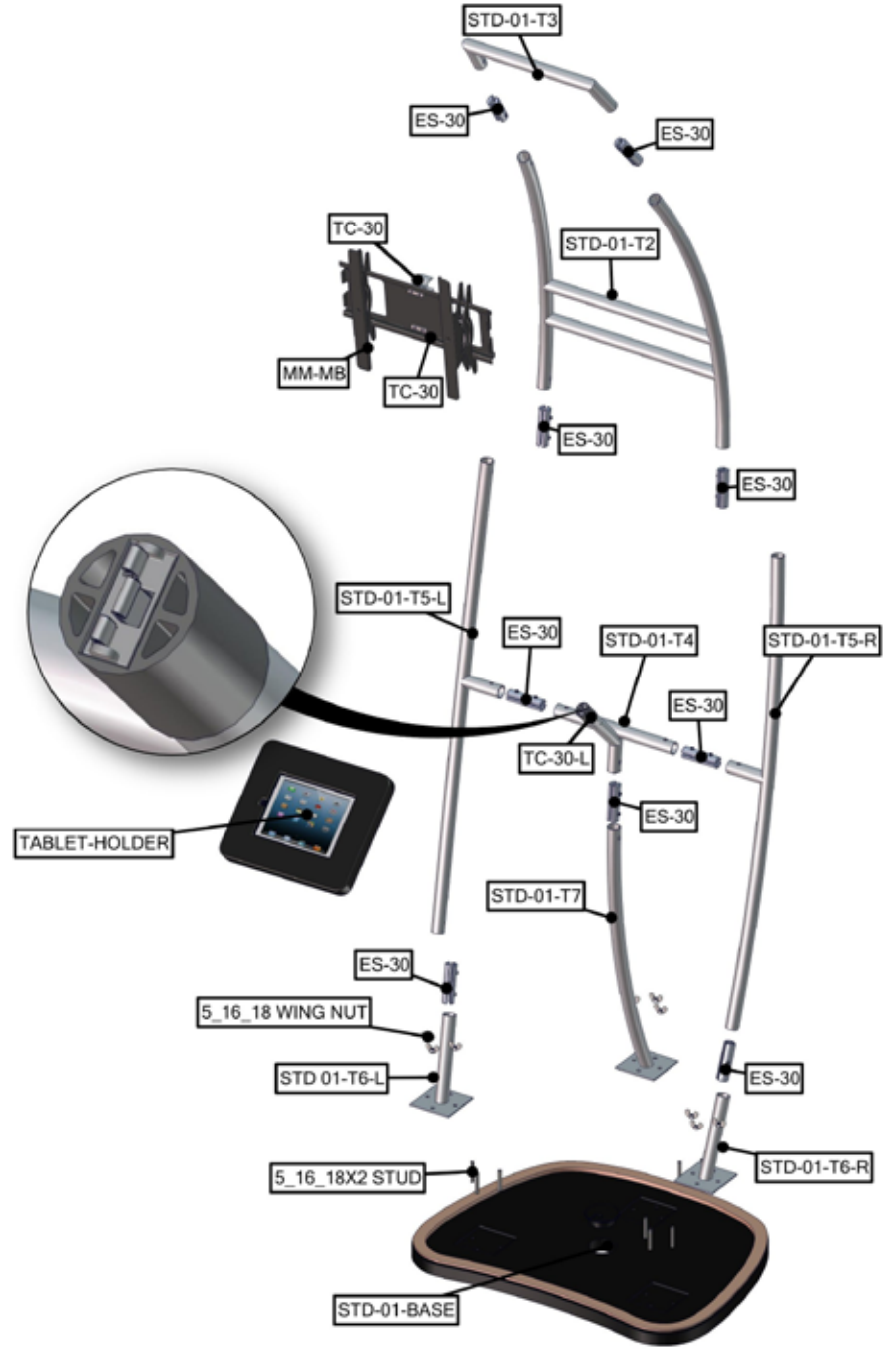
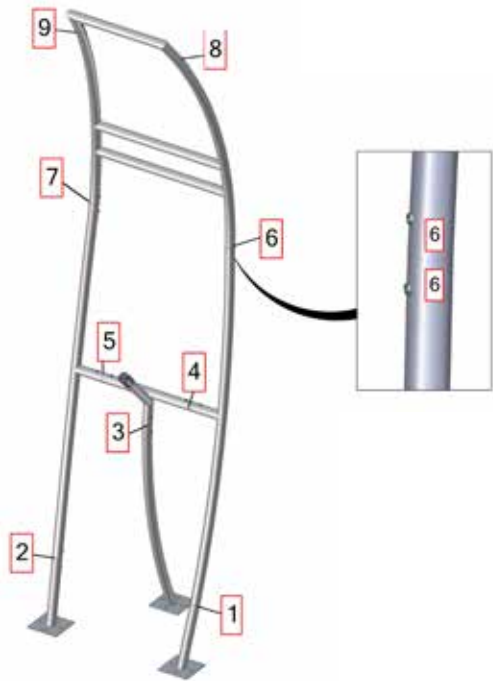

STEP 1: ASSEMBLE FRAME

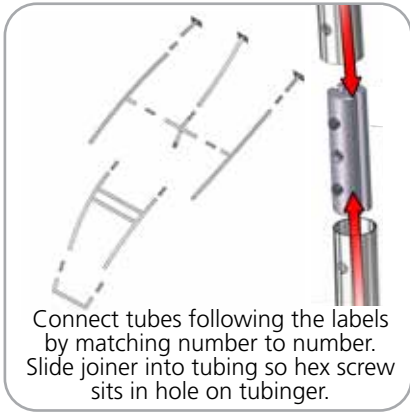

Connect tubes following the labels by matching number to number. Slide joiner into tubing so hex screw sits in hole on tubing.

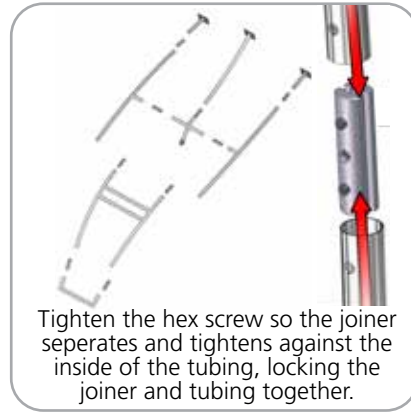

Tighten the hex screw so the joiner separates and tightens against the inside of the tubing, locking the joiner and tubing together.

STEP 2: ATTACH BASE

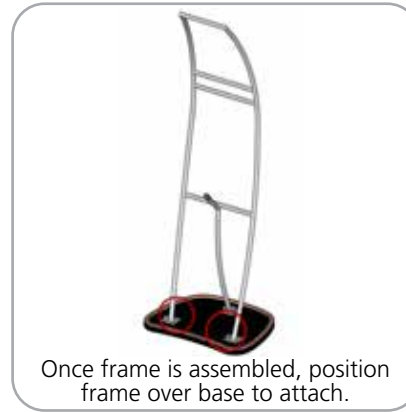

Once frame is assembled, position frame over base to attach.

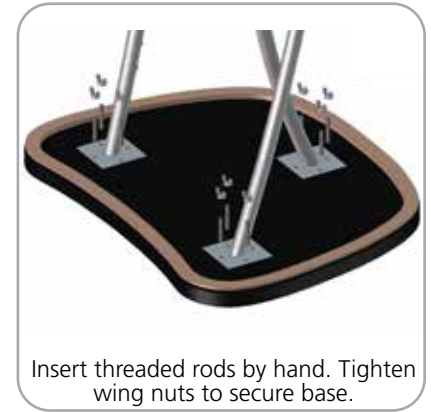

Insert threaded rods by hand. Tighten wing nuts to secure base.

STEP 3: ATTACH GRAPHICS



Pull graphic over top of frame.

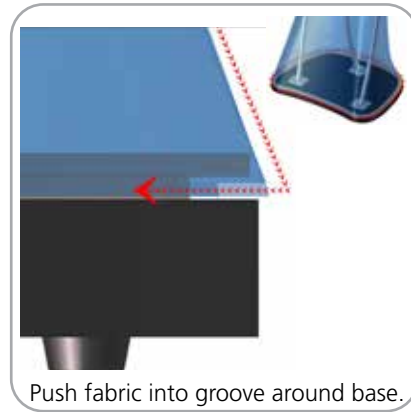

Push fabric into groove around base.

STEP 4: INSTALL MONITOR MOUNT

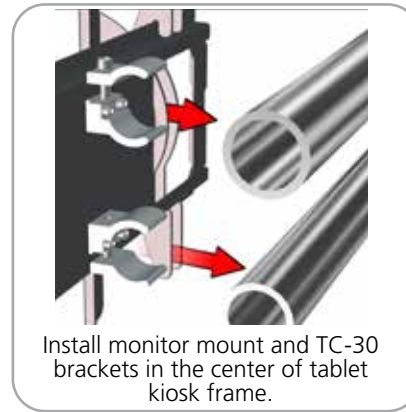

Install monitor mount and TC-30 brackets in the center of tablet kiosk frame.

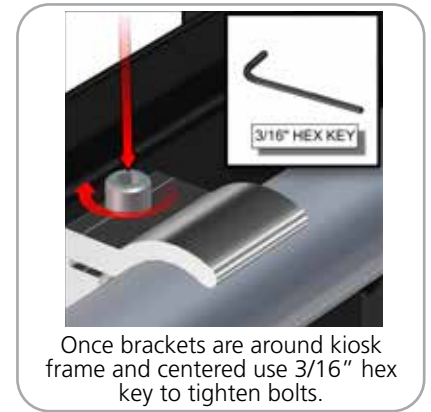

Once brackets are around the kiosk frame and centered use 3/16" hex key to tighten bolts.

STEP 5: INSTALL TABLET HOLDER



Once monitor mount is installed, begin tablet attachment.

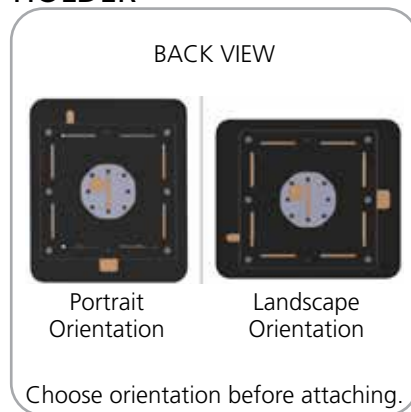

Choose orientation before attaching.

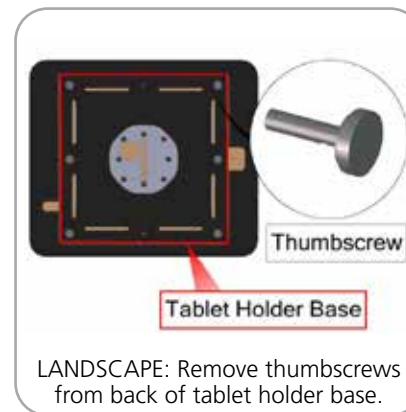

LANDSCAPE: Remove thumbscrews from back of tablet holder base.

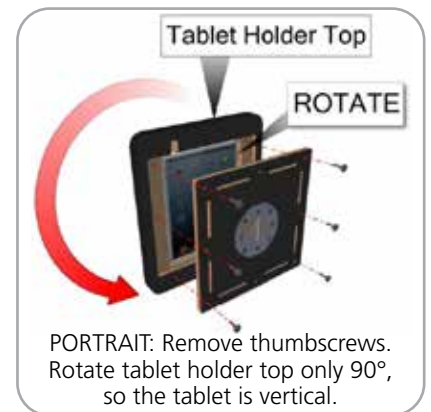

PORTRAIT: Remove thumbscrews. Rotate tablet holder top only 90°, so the tablet is vertical.

