

# Hybrid Pro Modular Kit 16

## HP-K-16

Hybrid Pro™ Modular exhibits and counters are a perfect solution for the serious exhibitor. Exhibits feature heavy-duty aluminum extrusion frames and push-fit fabric graphics. Count on making an unforgettable impact with Hybrid Pro Modular exhibit kits, counters, and accessories.

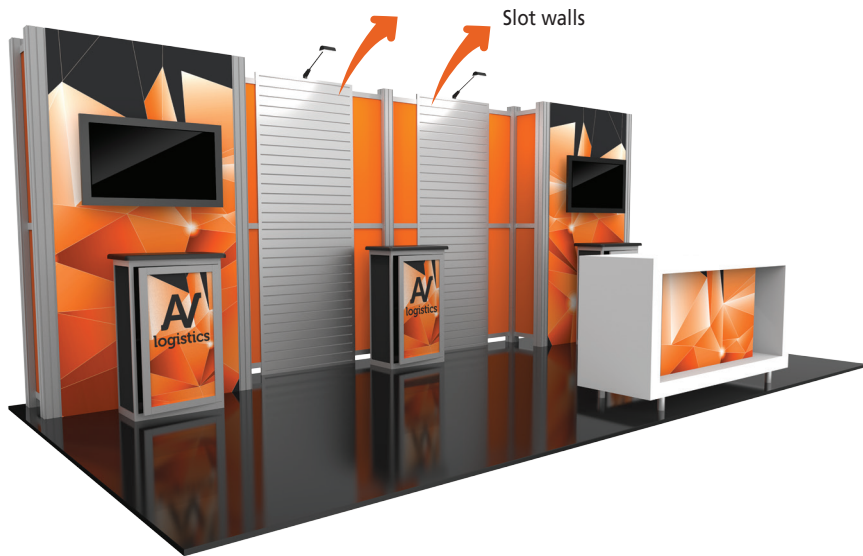

\* foreground counter not included

## features and benefits:

- Silver aluminum extrusion frame
- Slot walls
- Single-sided SEG dye-sublimated push-fit fabric graphics
- UV graphic printed on 6mm white printed Sintra infills
- Kit includes frame, two slot walls, two fabric graphic panels, sixteen Sintra infills, three backwall counters, two medium monitor mounts, two 200 LED floodlights and one molded OCH2 case and one SCRATE case.
- Lifetime hardware warranty against manufacturer defects

## dimensions:

Hardware	Graphic
<p>Assembled unit: 232.38" w x 94.5" h x 37.5" d 5902.45mm(w) x 2400.3mm(h) x 952.5mm(d)</p> <p>Counters (each): 25.5" w x 39.2" h x 15.1" d approx. 647.7mm(w) x 995.68mm(h) x 383.54mm(d)</p> <p>Counter (each) holds max weight 50 lbs / 22.68 kgs</p>	<p>Total visual area: UV Graphic Panels A, B, D, E, F, G, H, I, J, K, L, M, N, O, Q, R: 12.28" w x 43.28" h</p> <p>Dye Sub Graphic Panels C &amp; P: 47.125" w x 94.375" h</p> <p>Counter (UV graphic panels): Front: 21.31" w x 35.81" h Sides: 11" w x 35.81" h Door: 17.53" w x 32.18" h</p>
<p>Shipping</p> <p>Shipping dimensions - ships in 2 cases: 1 OCH2 case: 52" l x 30" h x 15" d 1320.8mm(l) x 762mm(h) x 381mm(d)</p> <p>1 SCRATE case: 59" l x 57" h x 34" d 1498.6mm(l) x 1447.8mm(h) x 863.6mm(d)</p> <p>Approximate shipping weight (entire kit): 658 lbs / 298.5 kgs</p>	<p>Please be sure to include a 2" bleed around the perimeter.</p> <p>Refer to related graphic templates for more information</p> <p>Visit: <a href="http://www.exhibitors-handbook.com/graphic-templates">www.exhibitors-handbook.com/graphic-templates</a></p>

## additional information:

Fabric material: Dye-sublimated fabric and UV printed on 6mm white Sintra

Tabletop color options:



silver black mahogany natural

\*Foreground counter and monitors not included

Lights Included: Lumina 200 LED floodlight, straight arm and adjustable head, black finish, 19.5" from end to end

Medium monitor bracket holds 26-40" LCD, maximum weight 50 lbs / 22.68 kgs

We are continually improving and modifying our product range and reserve the right to vary the specifications without prior notice. All dimensions and weights quoted are approximate and we accept no responsibility for variance. E&OE. See Graphic Templates for graphic bleed specifications.

R-HP-K-16

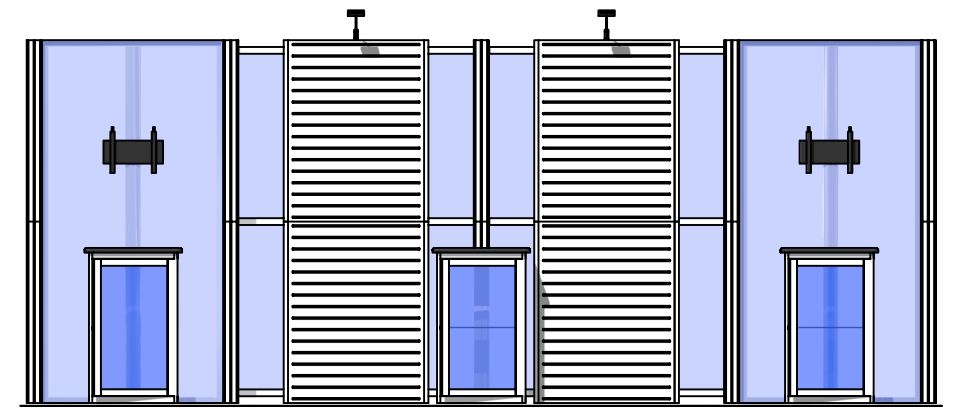
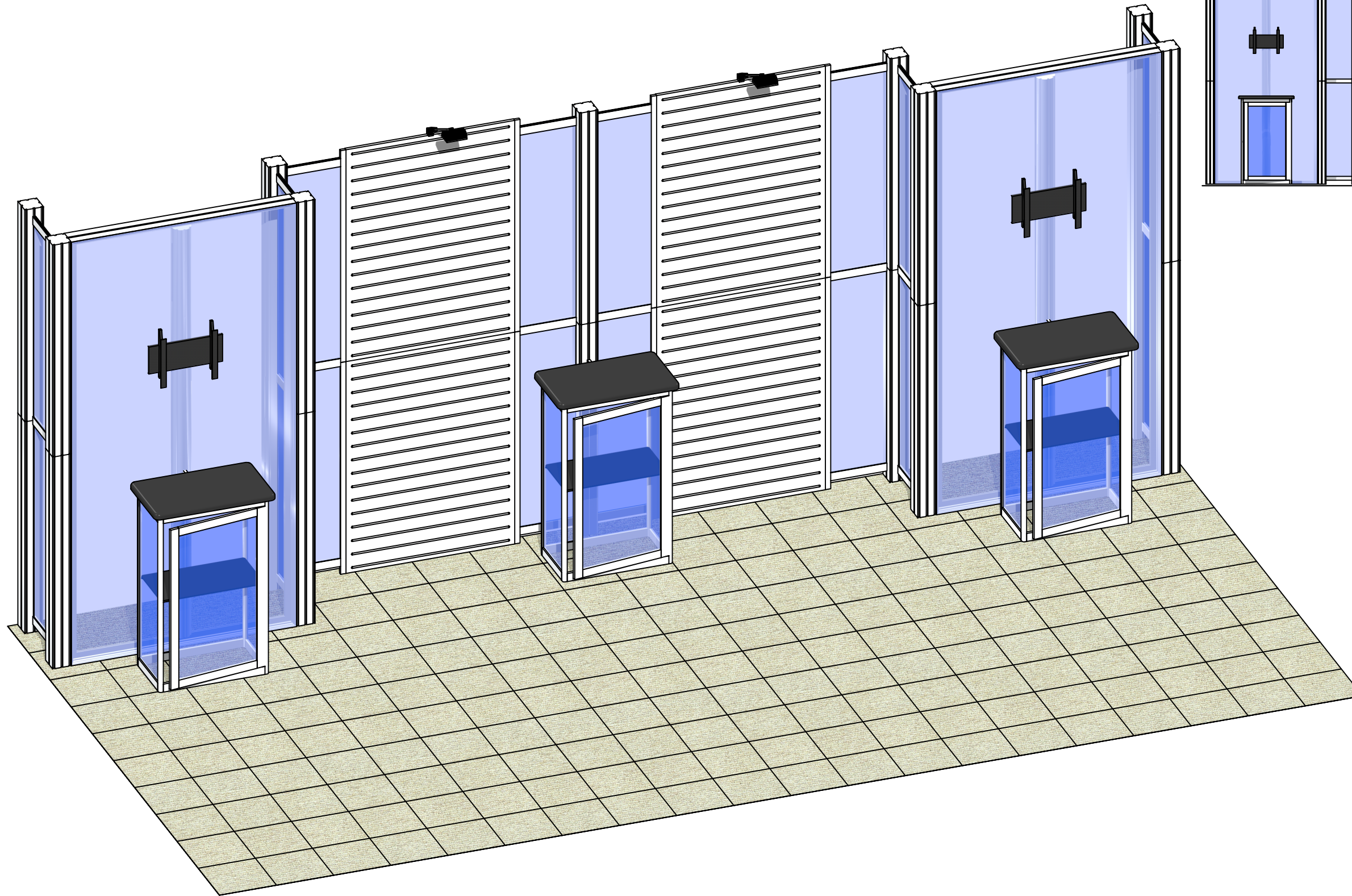

Code	#	Description
R11	8	1200MM (47.24") PHFC4 EXTRUSION WITH MITRE CUT 1 END FOR CB9 ONE END-IB2 HOLES ONE END WITH B
IB2	4	PH INLINE CONNECTOR
CB9	8	CB9 CORNER BRACKET
R9	4	1200MM (47.24") PHFC4 EXTRUSION WITH MITRE CUT BOTH ENDS
MM-MB	2	MEDIUM MONITOR BRACKET FOR MONITORS 15"-40"
GRAPHIC A	1	94.48" H x 47.24" W SINGLE SIDED (UNLINED) DYESUB GRAPHIC W/ FCE2 ALL 4 SIDES
R15	18	1200MM (47.24") 100MM PM4S2 SQUARE EXTRUSION WITH PH2 STOP AT 305MM BOTH ENDS
LED L10S	2	LED SPOTLIGHT, SILVER,3M,UL PLUG W/TRANSFORMER
R8	24	300MM (11.81") PH EXTRUSION WITH LOCKS 2 ENDS
R12	2	1155MM (45.47") 100MM PM4R8 ROUND EXTRUSION WITH PH2 STOP AT 305MM
R12	2	1155MM (45.47") 100MM PM4R8 ROUND EXTRUSION WITH LOCKS 1 END
R14	2	300MM (11.81") PM4D CONNECTOR WITH TENSION GLIDES
GRAPHIC I1	1	43.26" H x 12.28" W SINGLE SIDED DSG GRAPHIC ON 6MM WHITE SINTRA
GRAPHIC F	1	94.48" H x 47.24" W SINGLE SIDED (UNLINED) DYESUB GRAPHIC W/ FCE2 ALL 4 SIDES
R47	4	1200MM x 900MM LAMINATE SLOTWALL PANEL
GRAPHIC G2	1	43.26" H x 12.28" W SINGLE SIDED DSG GRAPHIC ON 6MM WHITE SINTRA
GRAPHIC G1	1	43.26" H x 12.28" W SINGLE SIDED DSG GRAPHIC ON 6MM WHITE SINTRA
GRAPHIC B2	1	43.26" H x 12.28" W SINGLE SIDED DSG GRAPHIC ON 6MM WHITE SINTRA
GRAPHIC B1	1	43.26" H x 12.28" W SINGLE SIDED DSG GRAPHIC ON 6MM WHITE SINTRA
GRAPHIC H2	1	43.26" H x 12.28" W SINGLE SIDED DSG GRAPHIC ON 6MM WHITE SINTRA
GRAPHIC H1	1	43.26" H x 12.28" W SINGLE SIDED DSG GRAPHIC ON 6MM WHITE SINTRA
GRAPHIC J2	1	43.26" H x 12.28" W SINGLE SIDED DSG GRAPHIC ON 6MM WHITE SINTRA
GRAPHIC J1	1	43.26" H x 12.28" W SINGLE SIDED DSG GRAPHIC ON 6MM WHITE SINTRA
GRAPHIC E2	1	43.26" H x 12.28" W SINGLE SIDED DSG GRAPHIC ON 6MM WHITE SINTRA
GRAPHIC E1	1	43.26" H x 12.28" W SINGLE SIDED DSG GRAPHIC ON 6MM WHITE SINTRA
GRAPHIC D2	1	43.26" H x 12.28" W SINGLE SIDED DSG GRAPHIC ON 6MM WHITE SINTRA
GRAPHIC D1	1	43.26" H x 12.28" W SINGLE SIDED DSG GRAPHIC ON 6MM WHITE SINTRA
GRAPHIC C2	1	43.26" H x 12.28" W SINGLE SIDED DSG GRAPHIC ON 6MM WHITE SINTRA
GRAPHIC C1	1	43.26" H x 12.28" W SINGLE SIDED DSG GRAPHIC ON 6MM WHITE SINTRA
R13	9	600MM (23.62") PM4D CONNECTOR WITH TENSION GLIDES
R48	3	100MM (3.94") PH1 EXTRUSION WITH LOCKS 2 ENDS
GRAPHIC I2	1	43.26" H x 12.28" W SINGLE SIDED DSG GRAPHIC ON 6MM WHITE SINTRA
R111	8	1200MM (47.24") P180 EXTRUSION W/LPJ

# BOM

R-HP-K-16

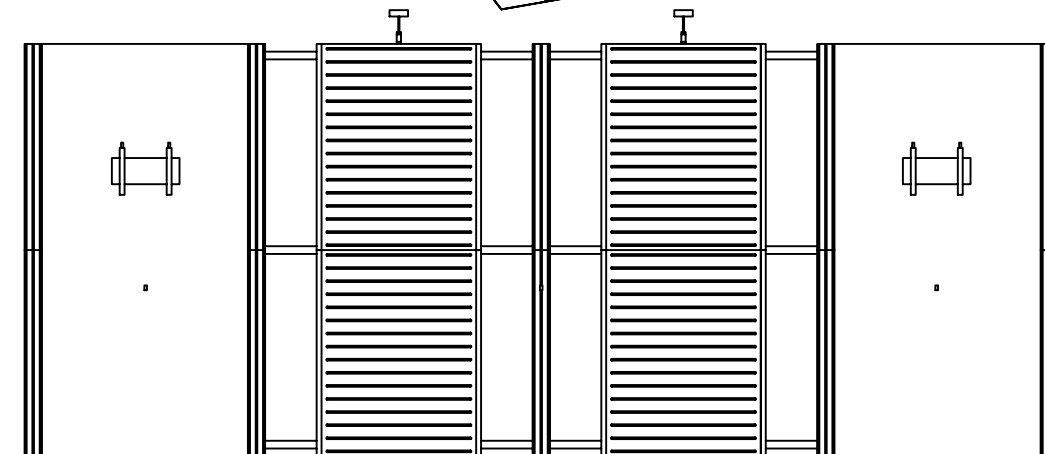
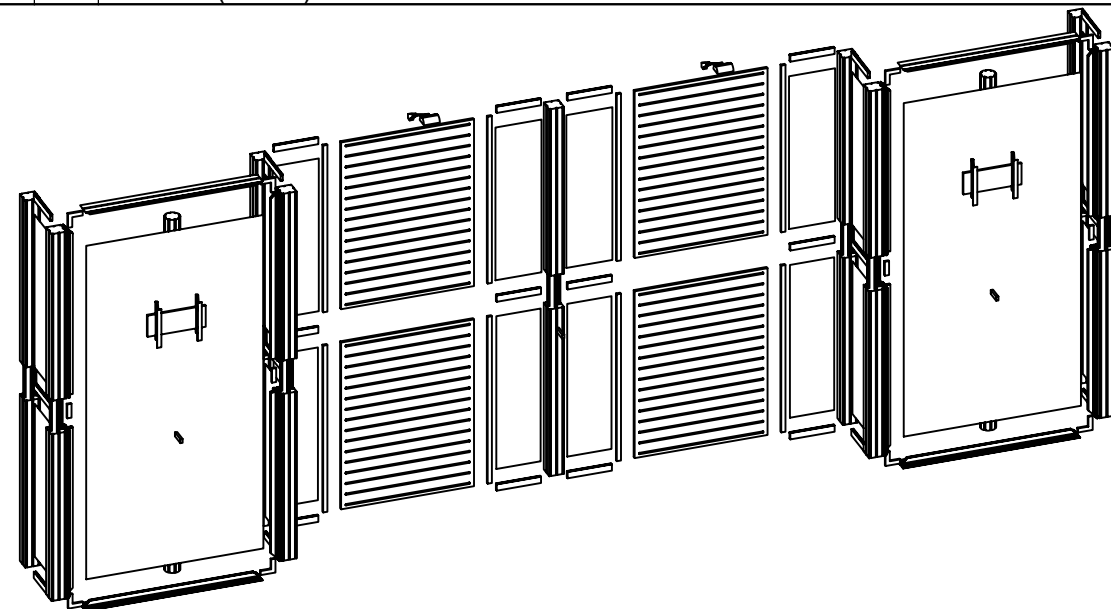
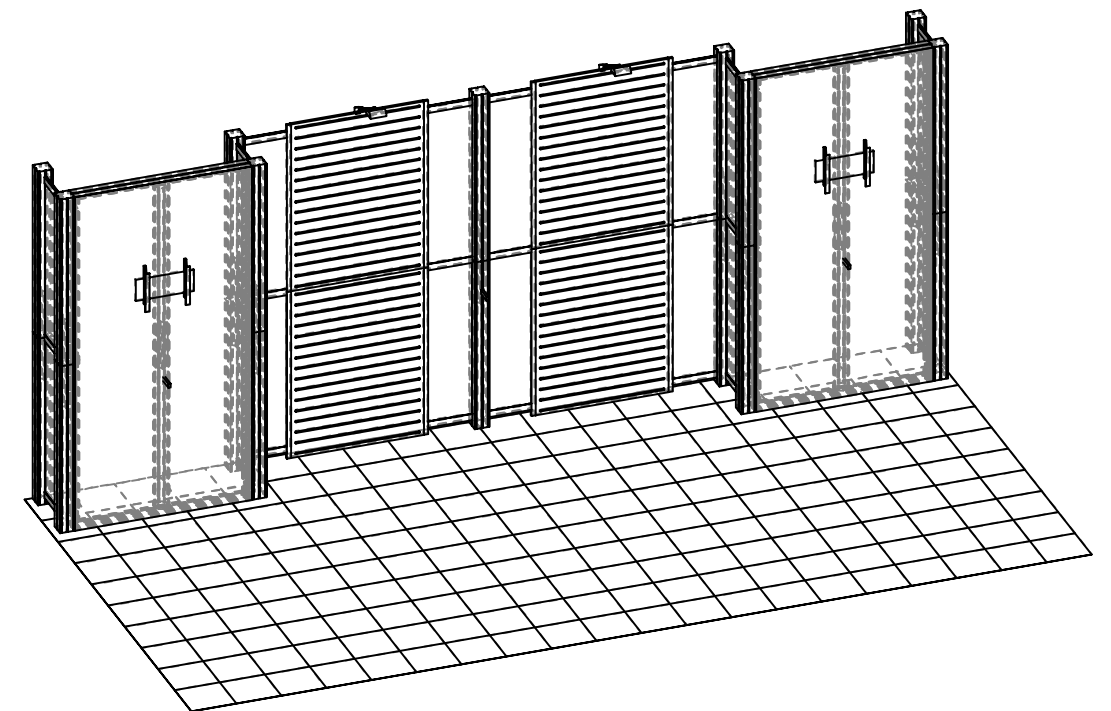
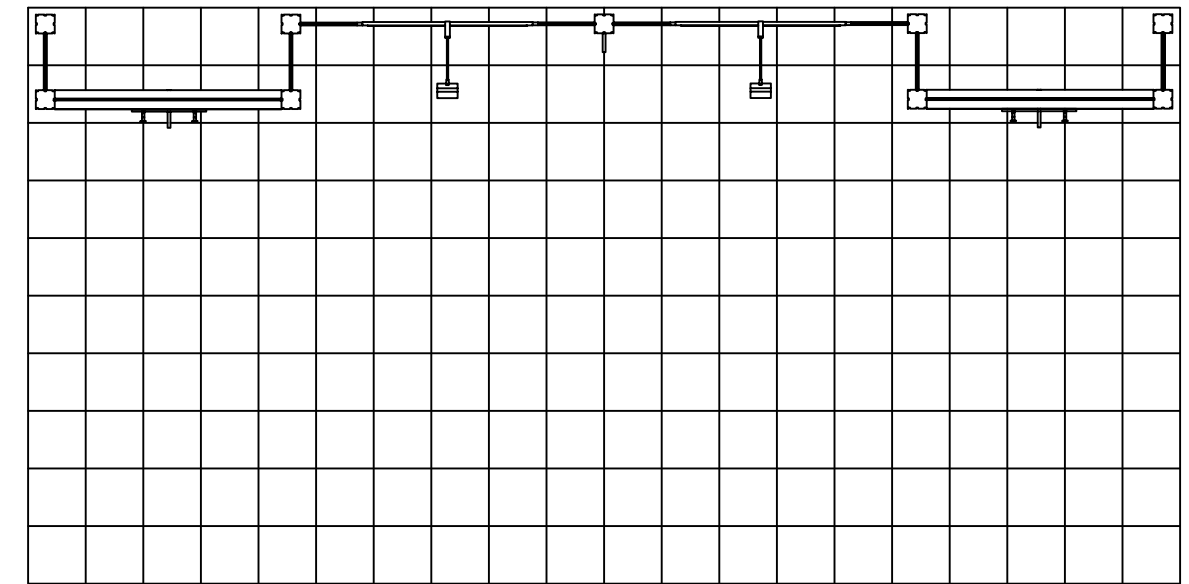

1. Redesign of this exhibit without approval by manufacturer may result in dangerous and unsafe structures. Manufacturer disclaims any responsibility for redesigned exhibits it does not approve in writing.

2. Parts and components such as panels and extrusions are manufactured to metric sizing. Where ever possible sizes have been noted in feet and inches as well as in metric. Below is the imperial to metric sizing table as reference. "Nominal" refers to approximate size.

- |                    |                                   |
|--------------------|-----------------------------------|
| 2400mm = (94 1/2") | ☒ Phone Line / Fax                |
| 2100mm = (82 5/8") | ☒ Internet connection             |
| 1800mm = (70 7/8") | ☒ Outlet                          |
| 1500mm = (59")     | ☒ Main Drop (point of distrution) |
| 1200mm = (47 1/4") |                                   |
| 900mm = (35 1/2")  |                                   |
| 600mm = (23 5/8")  |                                   |
| 300mm = (11 7/8")  |                                   |

--- Wire running under carpet

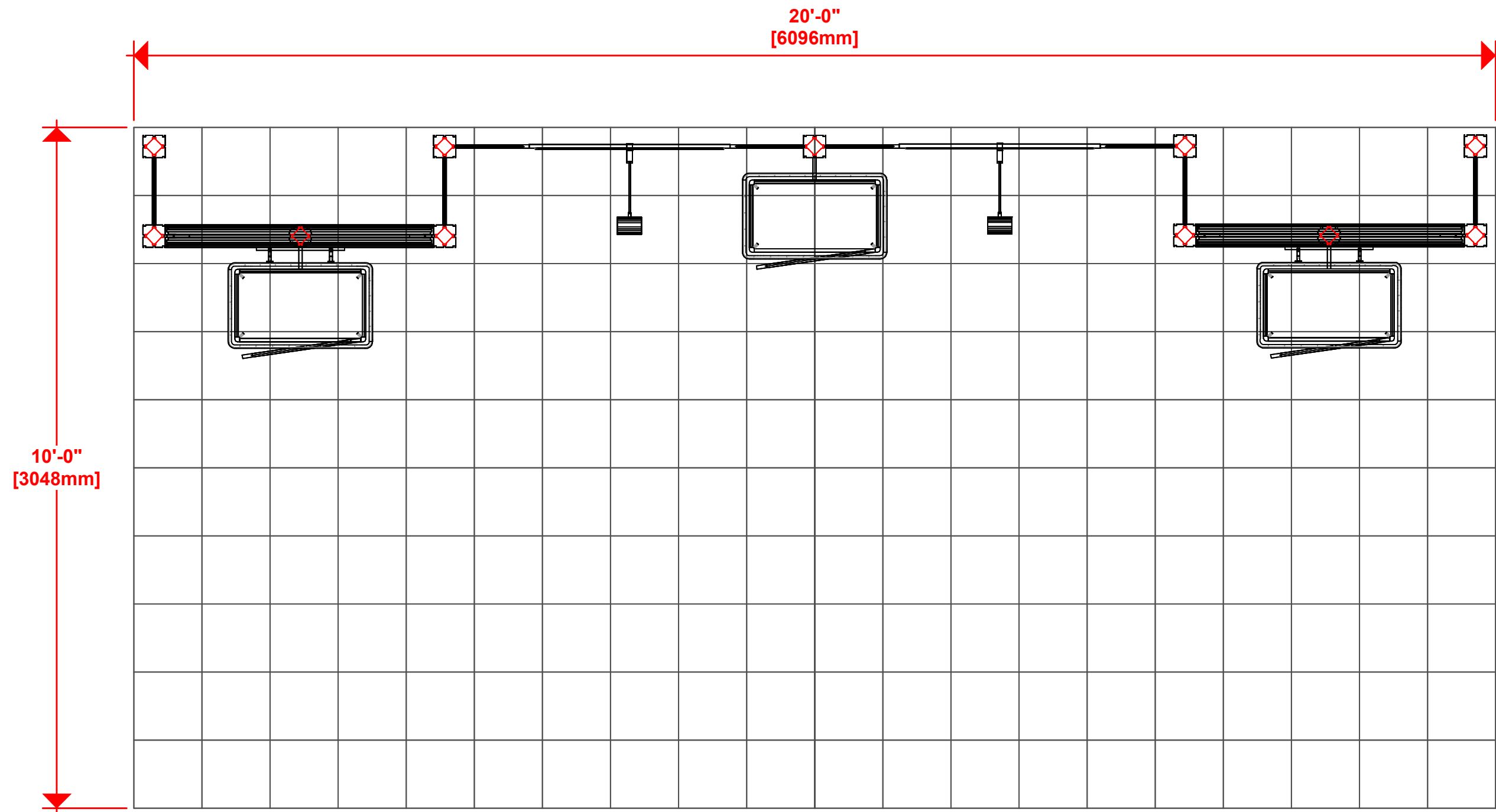

**(2) LED L10S LIGHTS = 50W PER STICK**

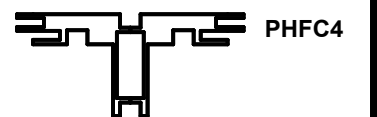
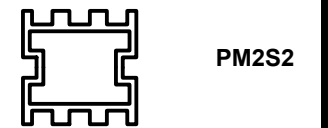

**HYBRID PRO RENTAL KIT**

Title: SET-UP INSTRUCTIONS

EP

Code	#	Description
R11	8	1200MM (47.24") PHFC4 EXTRUSION WITH MITRE CUT 1 END FOR CB9 ONE END-IB2 HOL
IB2	4	PH INLINE CONNECTOR
CB9	8	CB9 CORNER BRACKET
R9	4	1200MM (47.24") PHFC4 EXTRUSION WITH MITRE CUT BOTH ENDS
R12	2	1155MM (45.47") 100MM PM4R8 ROUND EXTRUSION WITH PH2 STOP AT 305MM
R12	2	1155MM (45.47") 100MM PM4R8 ROUND EXTRUSION WITH LOCKS 1 END
R14	2	300MM (11.81") PM4D CONNECTOR WITH TENSION GLIDES

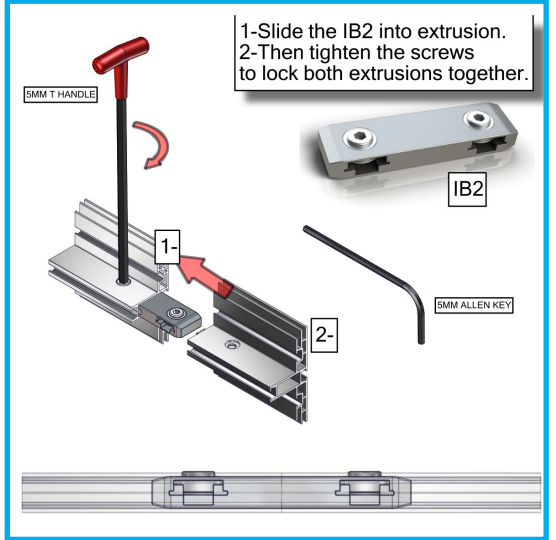
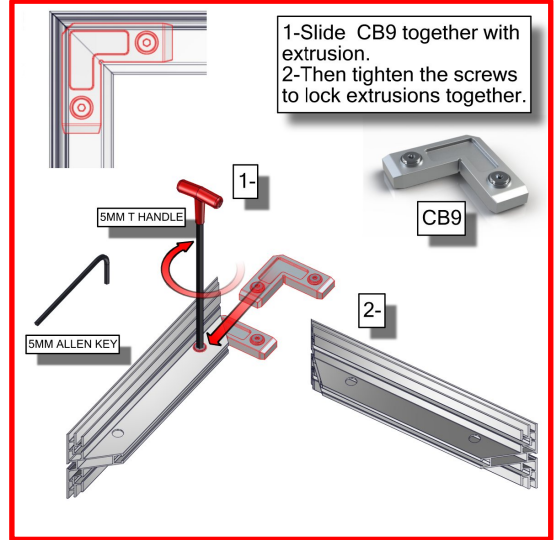
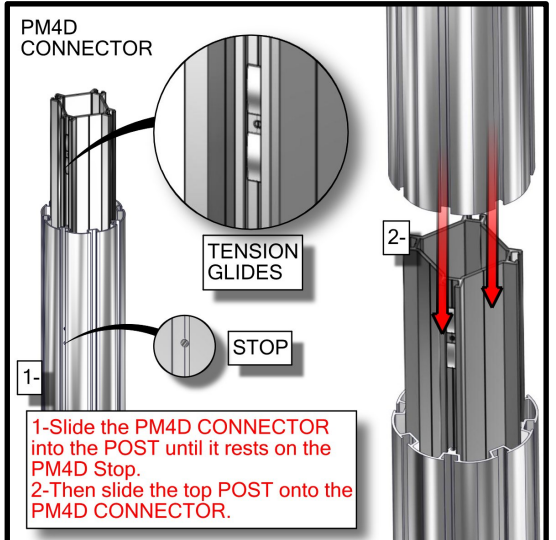
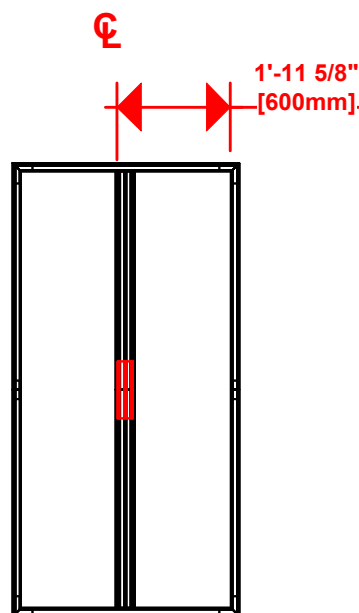
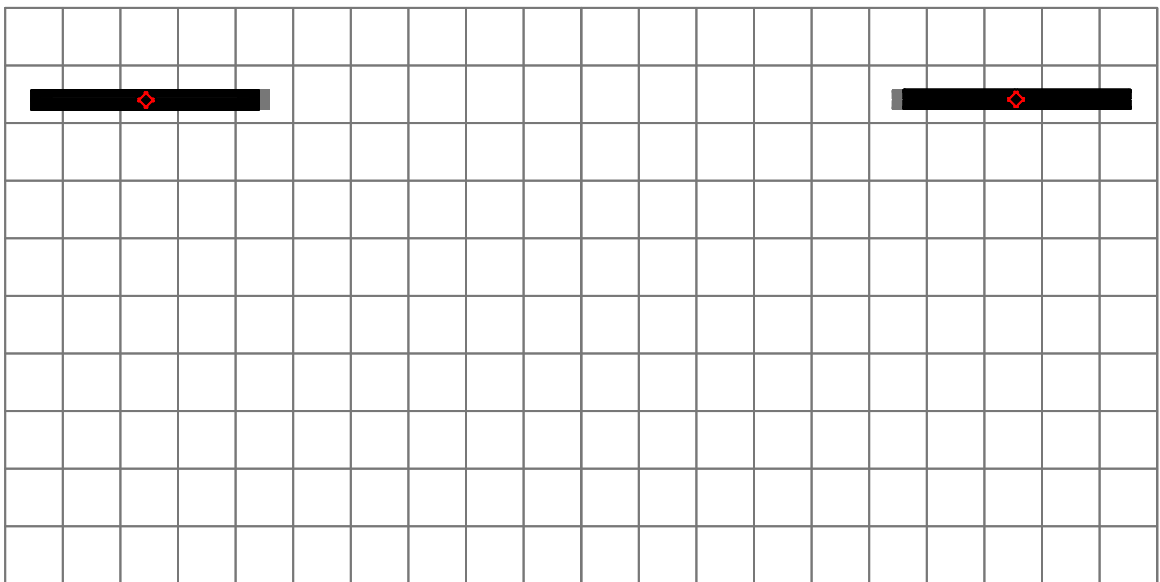
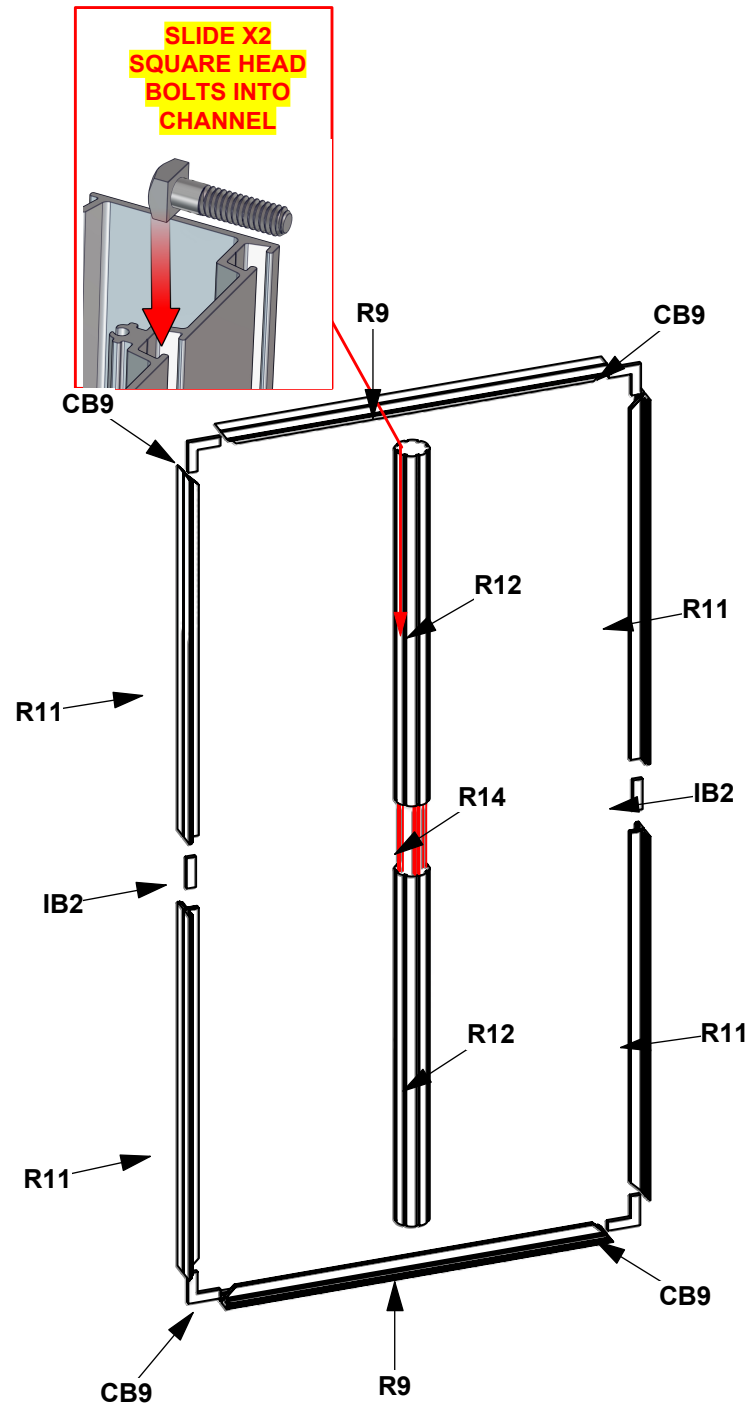

1. Redesign of this exhibit without approval by manufacturer may result in dangerous and unsafe structures. Manufacturer disclaims any responsibility for redesigned exhibits it does not approve in writing.

2. Parts and components such as panels and extrusions are manufactured to metric sizing. Where ever possible sizes have been noted in feet and inches as well as in metric. Below is the imperial to metric sizing table as reference. \*Nominal" refers to approximate size.

2400mm = (94 1/2")	Phone Line / Fax
2100mm = (82 5/8")	Internet connection
1800mm = (70 7/8")	Outlet
1500mm = (59")	Main Drop (point of distrution)
1200mm = (47 1/4")	
900mm = (35 1/2")	
600mm = (23 5/8")	
300mm = (11 7/8")	

--- Wire running under carpet

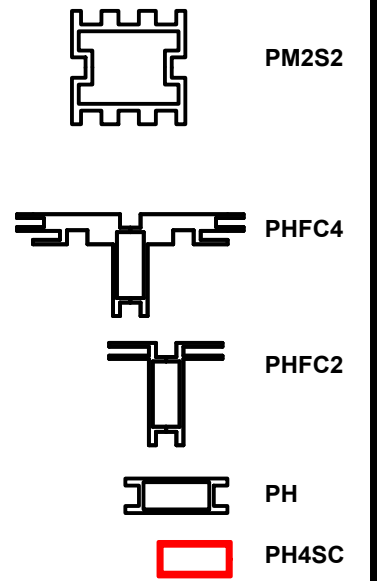

**BUILD 2 UNITS**

**HYBRID PRO RENTAL KIT**

Title: SET-UP INSTRUCTIONS

Code	#	Description
R15	9	1200MM (47.24") 100MM PM4S2 SQUARE EXTRUSION WITH PH2 STOP AT 305MM BC
R8	8	300MM (11.81") PH EXTRUSION WITH LOCKS 2 ENDS
R47	2	1200MM x 900MM LAMINATE SLOTWALL PANEL
R111	4	1200MM (47.24") P180 EXTRUSION WITH DI

**WARNING!**  
Locks should ONLY be turned a quarter turn, so as not to STRIP the locks by over torquing them

**WARNING!**  
Locks should ONLY be turned a quarter turn, so as not to STRIP the locks by over torquing them

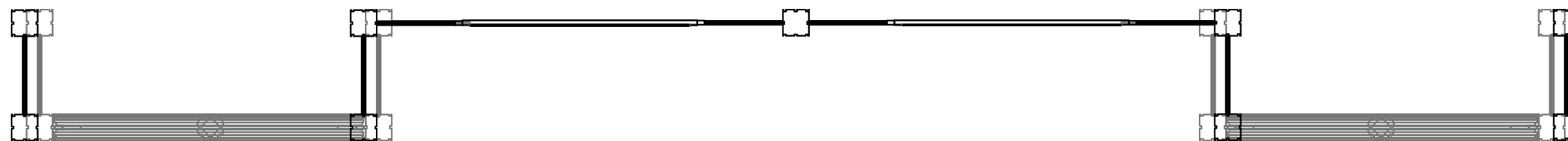
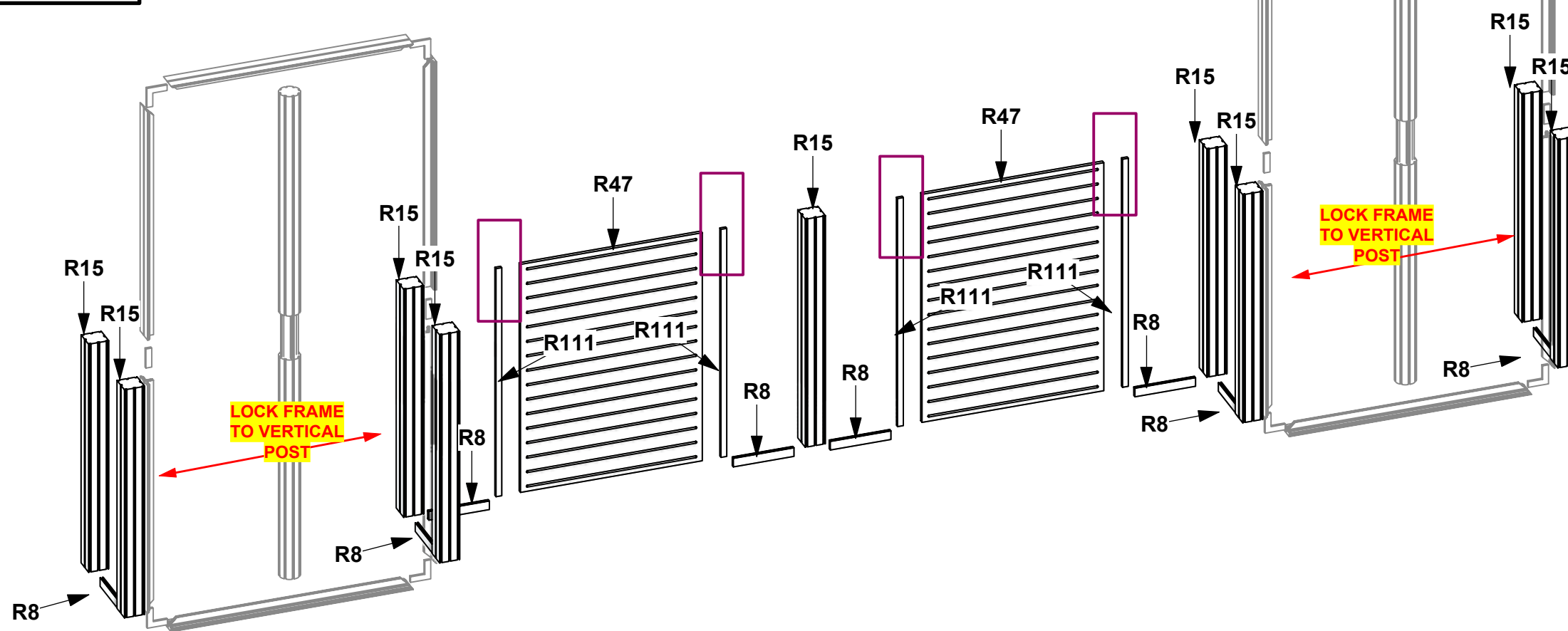
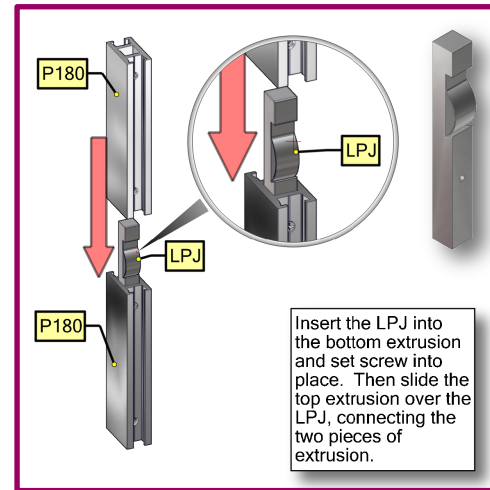
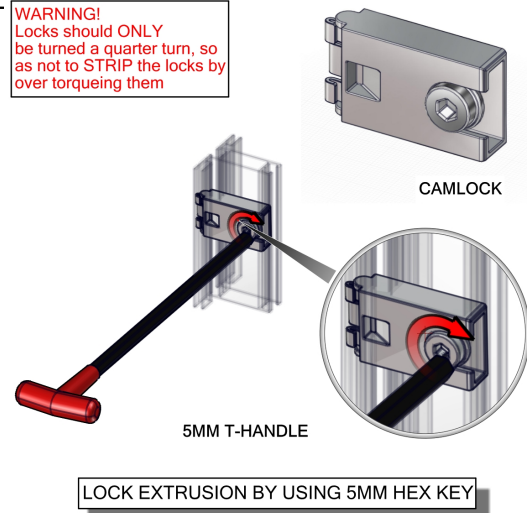
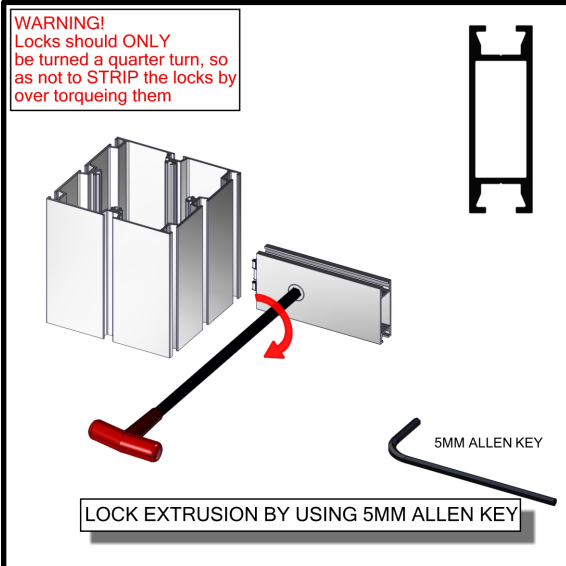

1. Redesign of this exhibit without approval by manufacturer may result in dangerous and unsafe structures. Manufacturer disclaims any responsibility for redesigned exhibits it does not approve in writing.

2. Parts and components such as panels and extrusions are manufactured to metric sizing. Where ever possible sizes have been noted in feet and inches as well as in metric. Below is the imperial to metric sizing table as reference. "Nominal" refers to approximate size.

2400mm = (94 1/2")	Phone Line / Fax
2100mm = (82 5/8")	Internet connection
1800mm = (70 7/8")	Outlet
1500mm = (59")	Main Drop (point of distrution)
1200mm = (47 1/4")	
900mm = (35 1/2")	
600mm = (23 5/8")	
300mm = (11 7/8")	

--- Wire running under carpet

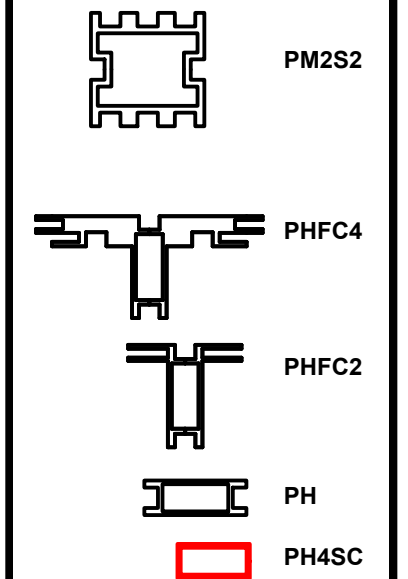

HYBRID PRO RENTAL KIT

Title: SET-UP INSTRUCTIONS

Code	#	Description
R15	9	1200MM (47.24") 100MM PM4S2 SQUARE EXTRUSION WITH PH2 STOP AT 305MM
R13	9	600MM (23.62") PM4D CONNECTOR WITH TENSION GLIDES

1. Redesign of this exhibit without approval by manufacturer may result in dangerous and unsafe structures. Manufacturer disclaims any responsibility for redesigned exhibits it does not approve in writing.

2. Parts and components such as panels and extrusions are manufactured to metric sizing. Where ever possible sizes have been noted in feet and inches as well as in metric. Below is the imperial to metric sizing table as reference. "Nominal" refers to approximate size.

2400mm = (94 1/2")	Phone Line / Fax
2100mm = (82 5/8")	Internet connection
1800mm = (70 7/8")	Outlet
1500mm = (59")	Main Drop (point of distrution)
1200mm = (47 1/4")	
900mm = (35 1/2")	
600mm = (23 5/8")	
300mm = (11 7/8")	

--- Wire running under carpet

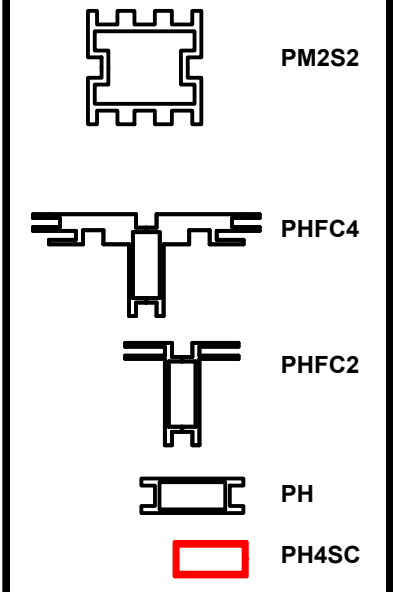
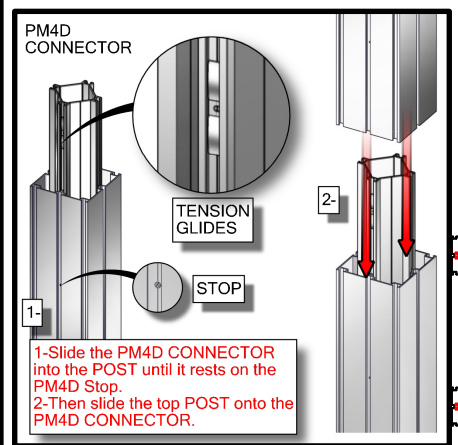
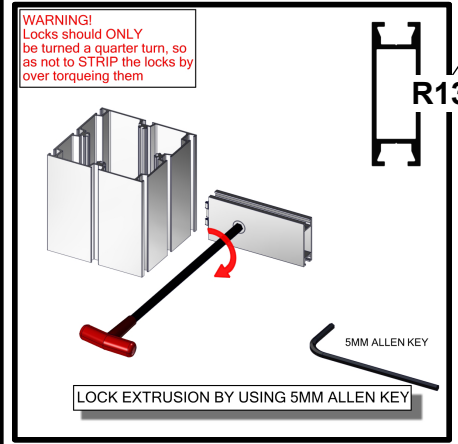
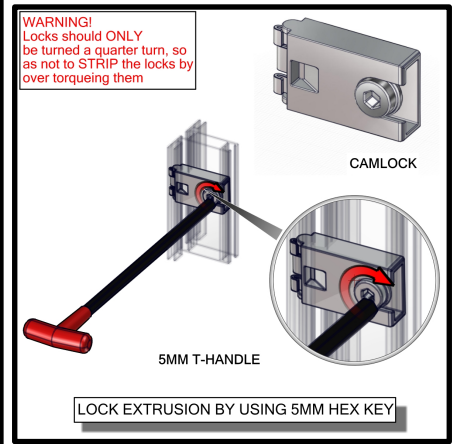
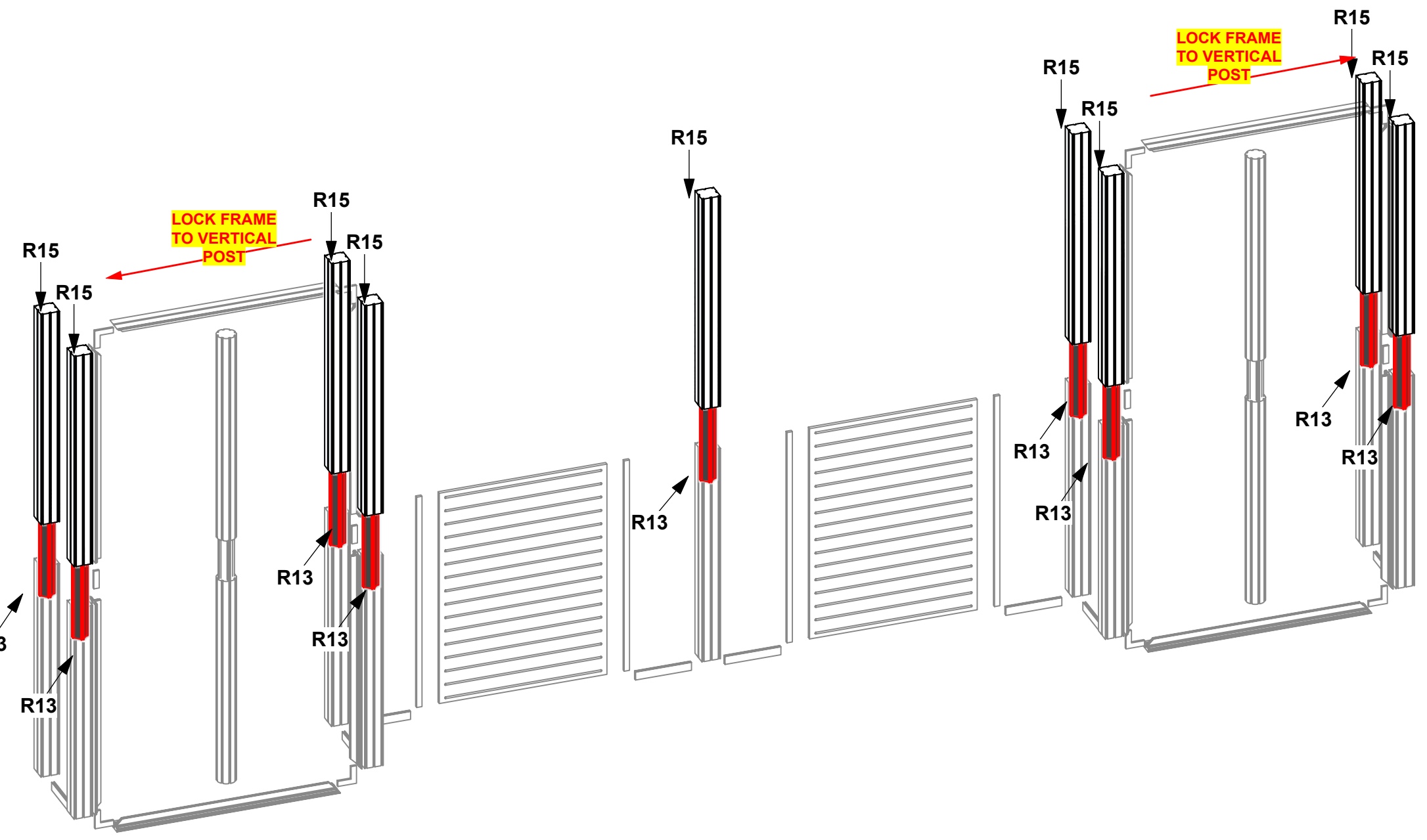

**HYBRID PRO RENTAL KIT**

Title: SET-UP INSTRUCTIONS

Code	#	Description
R8	8	300MM (11.81") PH EXTRUSION WITH LOCKS 2 ENDS
R47	2	1200MM x 900MM LAMINATE SLOTWALL PANEL
GRAPHIC B2	1	43.26" H x 12.28" W SINGLE SIDED DSG GRAPHIC ON 6MM WHITE SINTRA
GRAPHIC B1	1	43.26" H x 12.28" W SINGLE SIDED DSG GRAPHIC ON 6MM WHITE SINTRA
GRAPHIC E2	1	43.26" H x 12.28" W SINGLE SIDED DSG GRAPHIC ON 6MM WHITE SINTRA
GRAPHIC E1	1	43.26" H x 12.28" W SINGLE SIDED DSG GRAPHIC ON 6MM WHITE SINTRA
GRAPHIC D2	1	43.26" H x 12.28" W SINGLE SIDED DSG GRAPHIC ON 6MM WHITE SINTRA
GRAPHIC D1	1	43.26" H x 12.28" W SINGLE SIDED DSG GRAPHIC ON 6MM WHITE SINTRA
GRAPHIC C2	1	43.26" H x 12.28" W SINGLE SIDED DSG GRAPHIC ON 6MM WHITE SINTRA
GRAPHIC C1	1	43.26" H x 12.28" W SINGLE SIDED DSG GRAPHIC ON 6MM WHITE SINTRA
R111	4	1200MM (47.24") P180 EXTRUSION W/LPJ

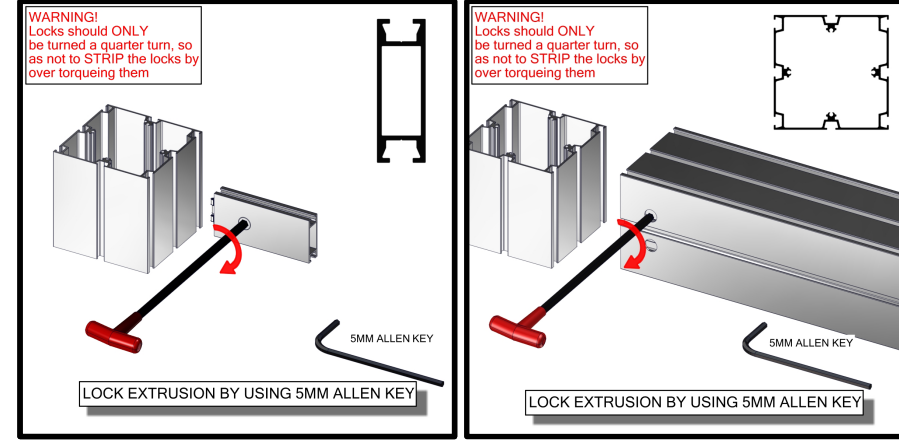

1. Redesign of this exhibit without approval by manufacturer may result in dangerous and unsafe structures. Manufacturer disclaims any responsibility for redesigned exhibits it does not approve in writing.

2. Parts and components such as panels and extrusions are manufactured to metric sizing. Where ever possible sizes have been noted in feet and inches as well as in metric. Below is the imperial to metric sizing table as reference. "Nominal" refers to approximate size.

2400mm = (94 1/2")	Phone Line / Fax
2100mm = (82 5/8")	Internet connection
1800mm = (70 7/8")	Outlet
1500mm = (59")	Main Drop (point of distrution)
1200mm = (47 1/4")	
900mm = (35 1/2")	
600mm = (23 5/8")	
300mm = (11 7/8")	

--- Wire running under carpet

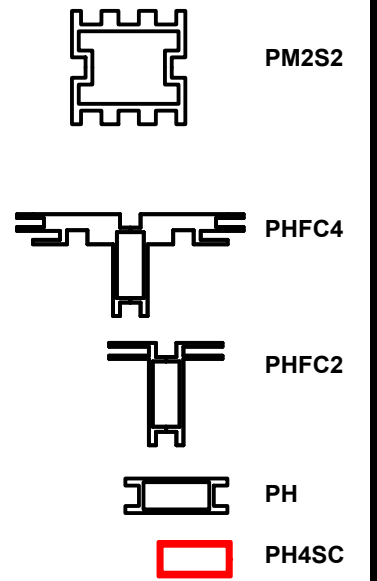
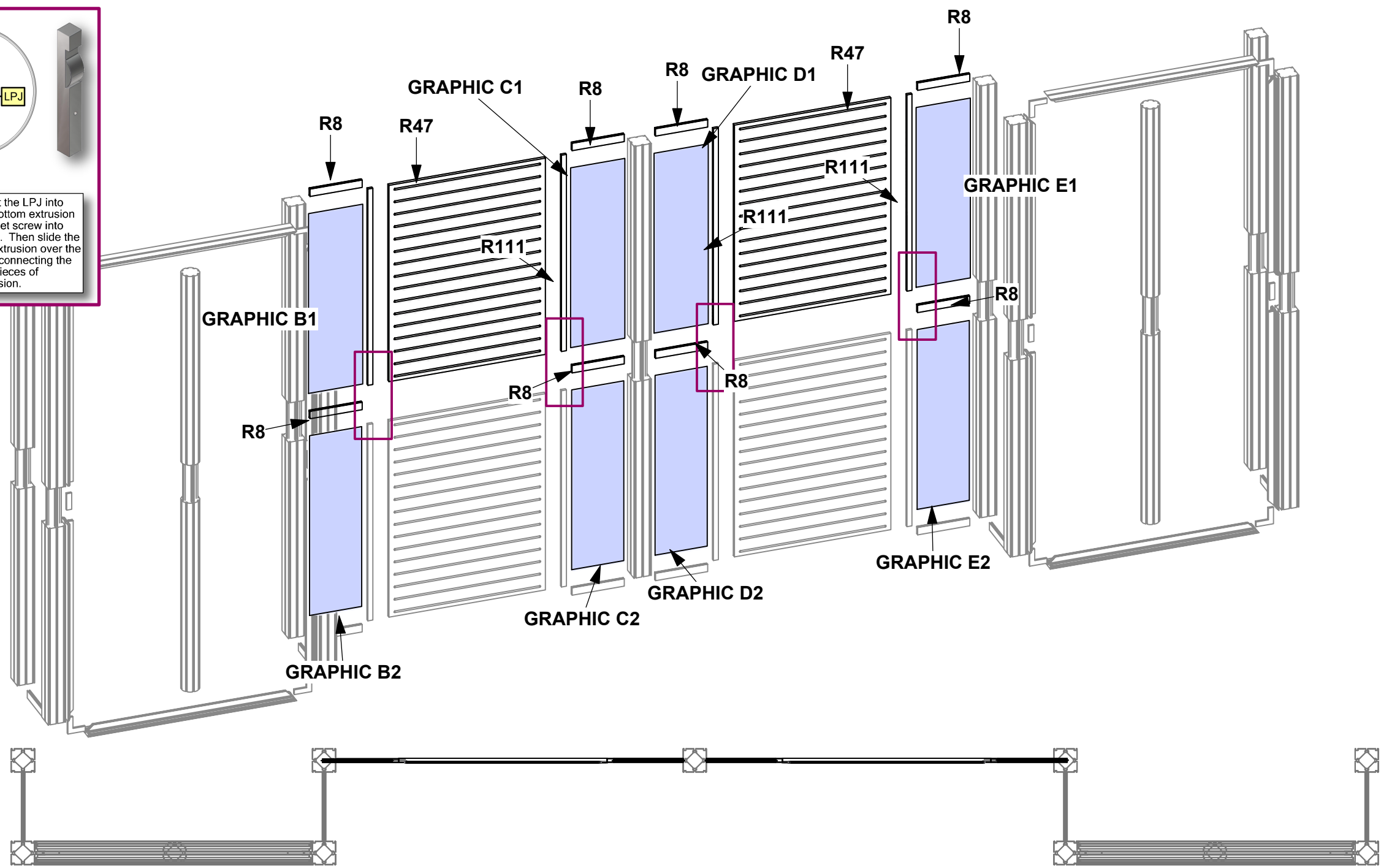
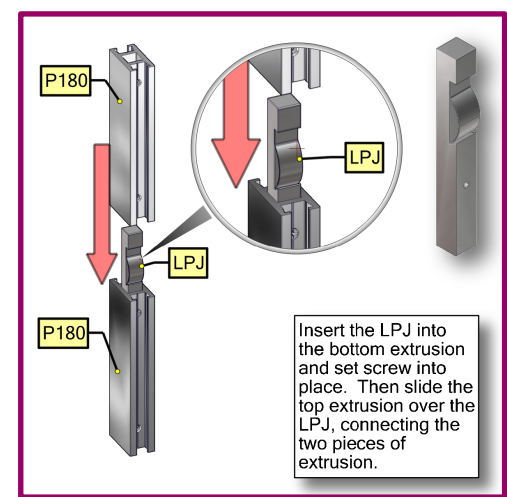

HYBRID PRO RENTAL KIT

Title: SET-UP INSTRUCTIONS



Code	#	Description
R8	8	300MM (11.81") PH EXTRUSION WITH LOCKS 2 ENDS
GRAPHIC G2	1	43.26" H x 12.28" W SINGLE SIDED DSG GRAPHIC ON 6MM WHITE SINTRA
GRAPHIC G1	1	43.26" H x 12.28" W SINGLE SIDED DSG GRAPHIC ON 6MM WHITE SINTRA
GRAPHIC H2	1	43.26" H x 12.28" W SINGLE SIDED DSG GRAPHIC ON 6MM WHITE SINTRA
GRAPHIC H1	1	43.26" H x 12.28" W SINGLE SIDED DSG GRAPHIC ON 6MM WHITE SINTRA

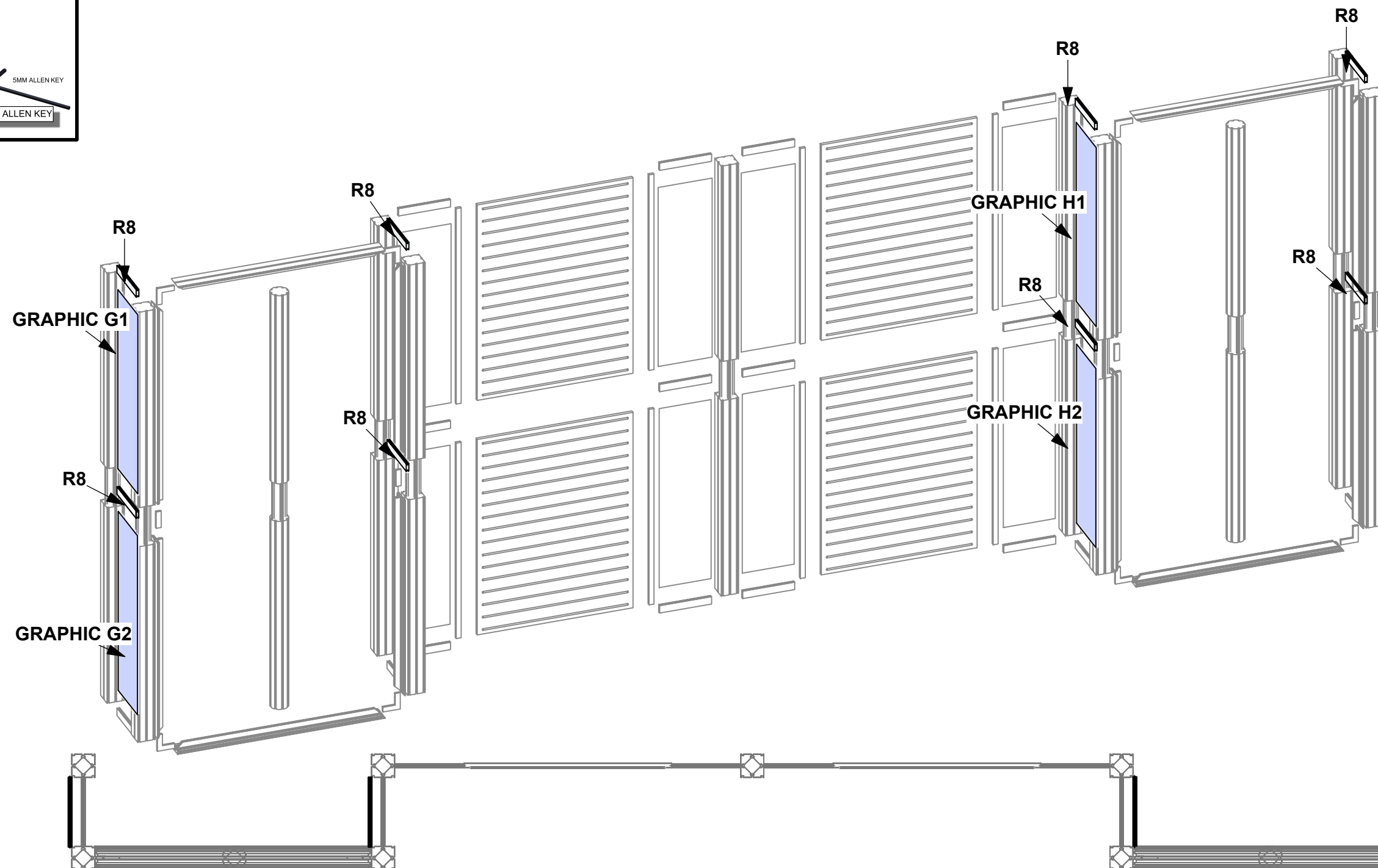
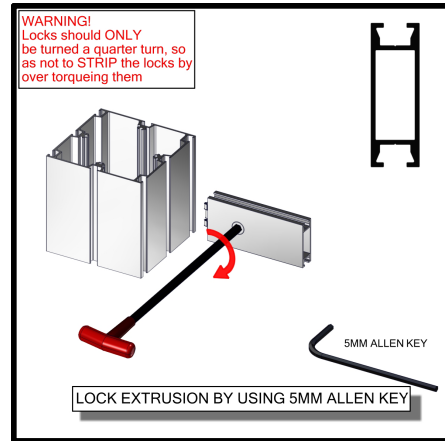

1. Redesign of this exhibit without approval by manufacturer may result in dangerous and unsafe structures. Manufacturer disclaims any responsibility for redesigned exhibits it does not approve in writing.

2. Parts and components such as panels and extrusions are manufactured to metric sizing. Where ever possible sizes have been noted in feet and inches as well as in metric. Below is the imperial to metric sizing table as reference. "Nominal" refers to approximate size.

2400mm = (94 1/2")	Phone Line / Fax
2100mm = (82 5/8")	Internet connection
1800mm = (70 7/8")	Outlet
1500mm = (59")	Main Drop (point of distrution)
1200mm = (47 1/4")	
900mm = (35 1/2")	
600mm = (23 5/8")	
300mm = (11 7/8")	

--- Wire running under carpet

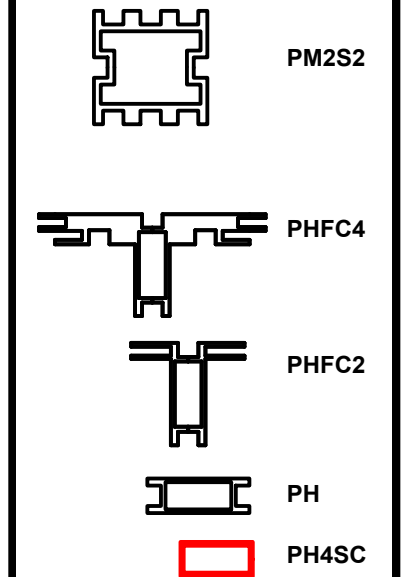

**HYBRID PRO RENTAL KIT**

Title: SET-UP INSTRUCTIONS

Code	#	Description
MM-MB	2	MEDIUM MONITOR BRACKET FOR MONITORS 15"-40"
GRAPHIC A	1	94.48" H x 47.24" W SINGLE SIDED (UNLINED) DYESUB GRAPHIC W/ FCE2 A
GRAPHIC F	1	94.48" H x 47.24" W SINGLE SIDED (UNLINED) DYESUB GRAPHIC W/ FCE2 A
R48	3	100MM (3.94") PH1 EXTRUSION WITH LOCKS 2 ENDS

1. Redesign of this exhibit without approval by manufacturer may result in dangerous and unsafe structures. Manufacturer disclaims any responsibility for redesigned exhibits it does not approve in writing.

2. Parts and components such as panels and extrusions are manufactured to metric sizing. Where ever possible sizes have been noted in feet and inches as well as in metric. Below is the imperial to metric sizing table as reference. "Nominal" refers to approximate size.

2400mm = (94 1/2")	Phone Line / Fax
2100mm = (82 5/8")	Internet connection
1800mm = (70 7/8")	Outlet
1500mm = (59")	Main Drop (point of distrution)
1200mm = (47 1/4")	
900mm = (35 1/2")	
600mm = (23 5/8")	
300mm = (11 7/8")	

--- Wire running under carpet

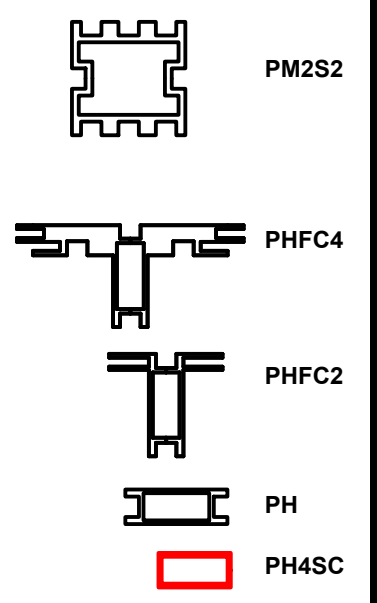
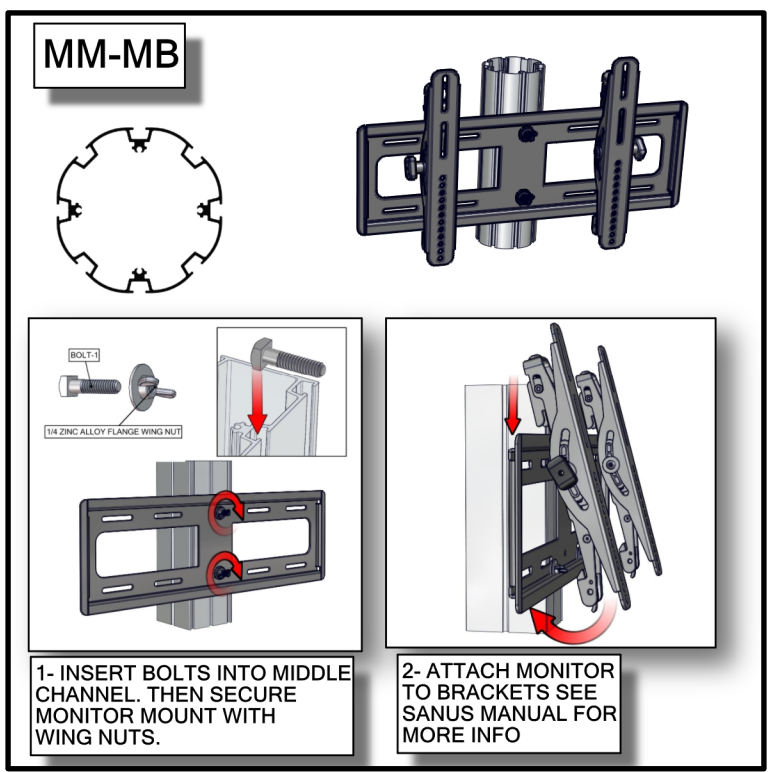
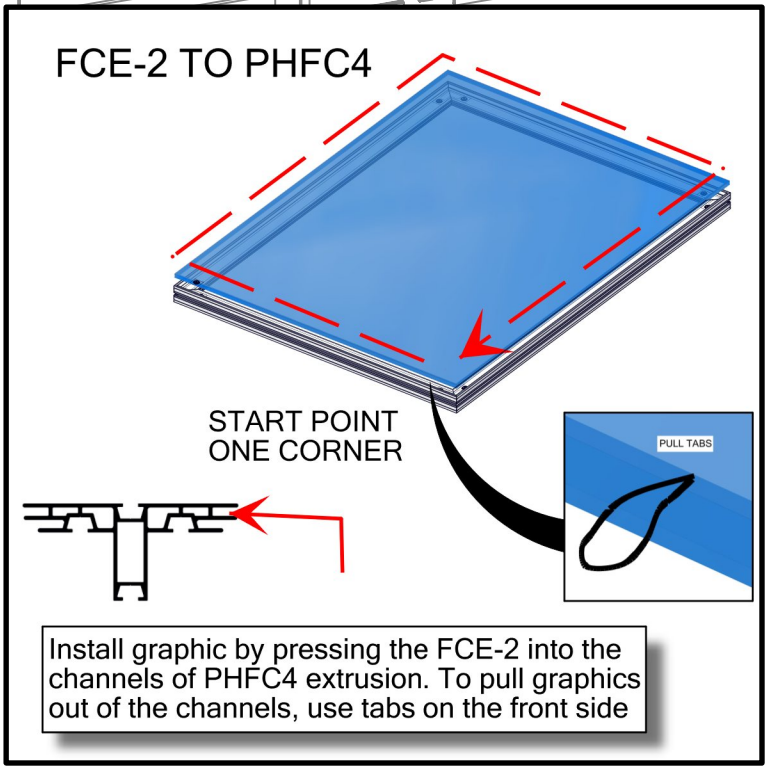
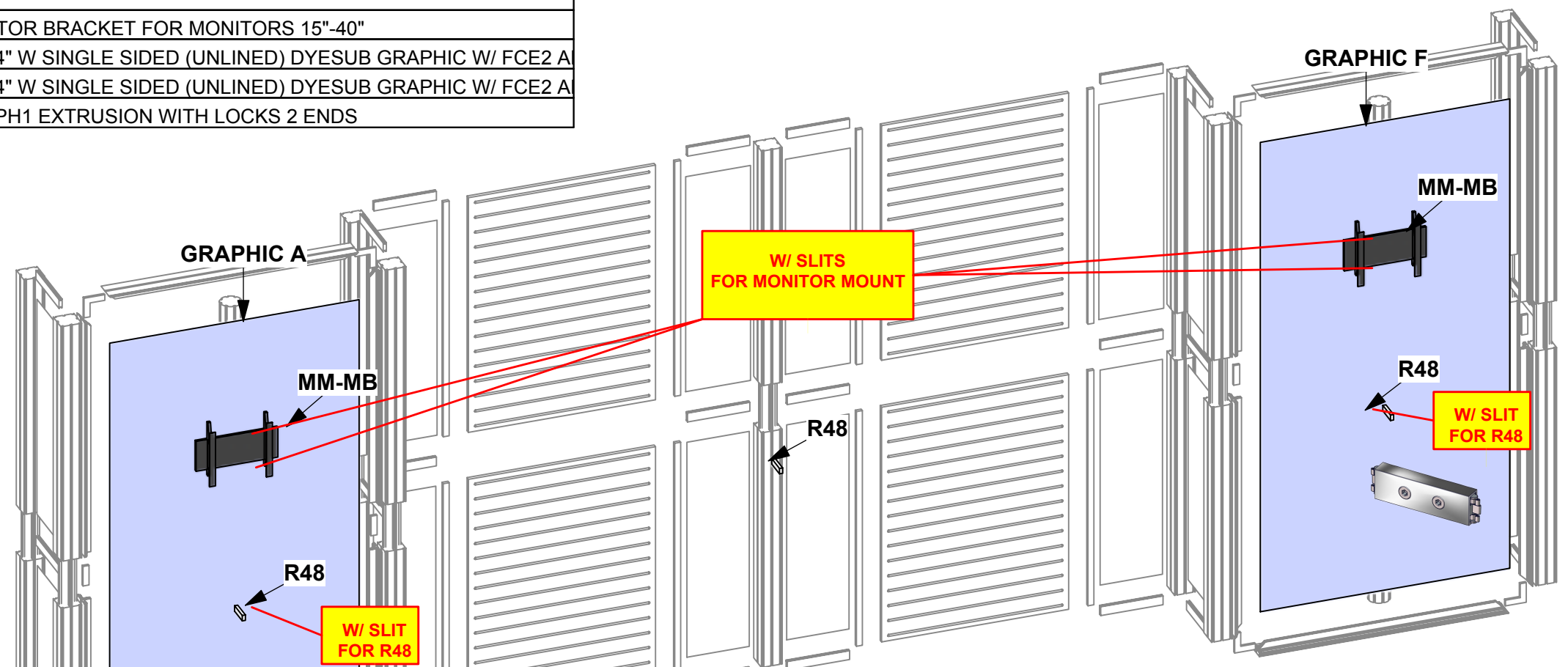
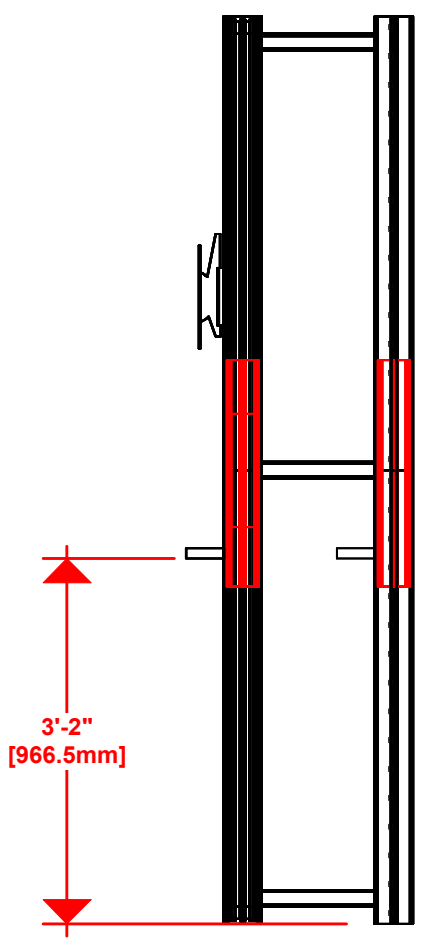

HYBRID PRO RENTAL KIT

Title: SET-UP INSTRUCTIONS

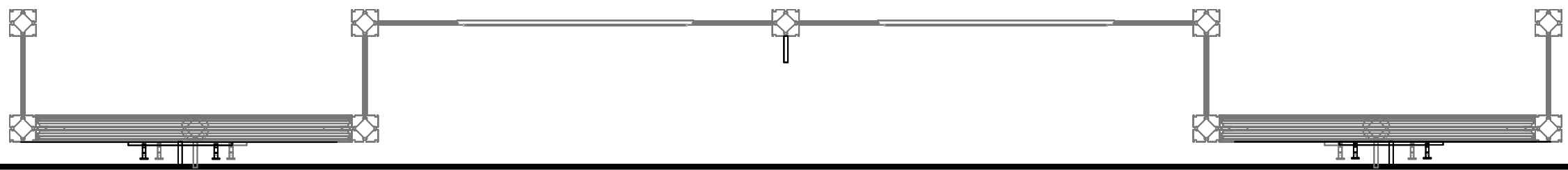

Code	#	Description
LED L10S	2	LED SPOTLIGHT, SILVER,3M,UL PLUG W/TRANSFORMER

1. Redesign of this exhibit without approval by manufacturer may result in dangerous and unsafe structures. Manufacturer disclaims any responsibility for redesigned exhibits it does not approve in writing.

2. Parts and components such as panels and extrusions are manufactured to metric sizing. Where ever possible sizes have been noted in feet and inches as well as in metric. Below is the imperial to metric sizing table as reference. "Nominal" refers to approximate size.

2400mm = (94 1/2")	☎ Phone Line / Fax
2100mm = (82 5/8")	🌐 Internet connection
1800mm = (70 7/8")	🔌 Outlet
1500mm = (59")	⚡ Main Drop (point of distrution)
1200mm = (47 1/4")	
900mm = (35 1/2")	
600mm = (23 5/8")	
300mm = (11 7/8")	

--- Wire running under carpet

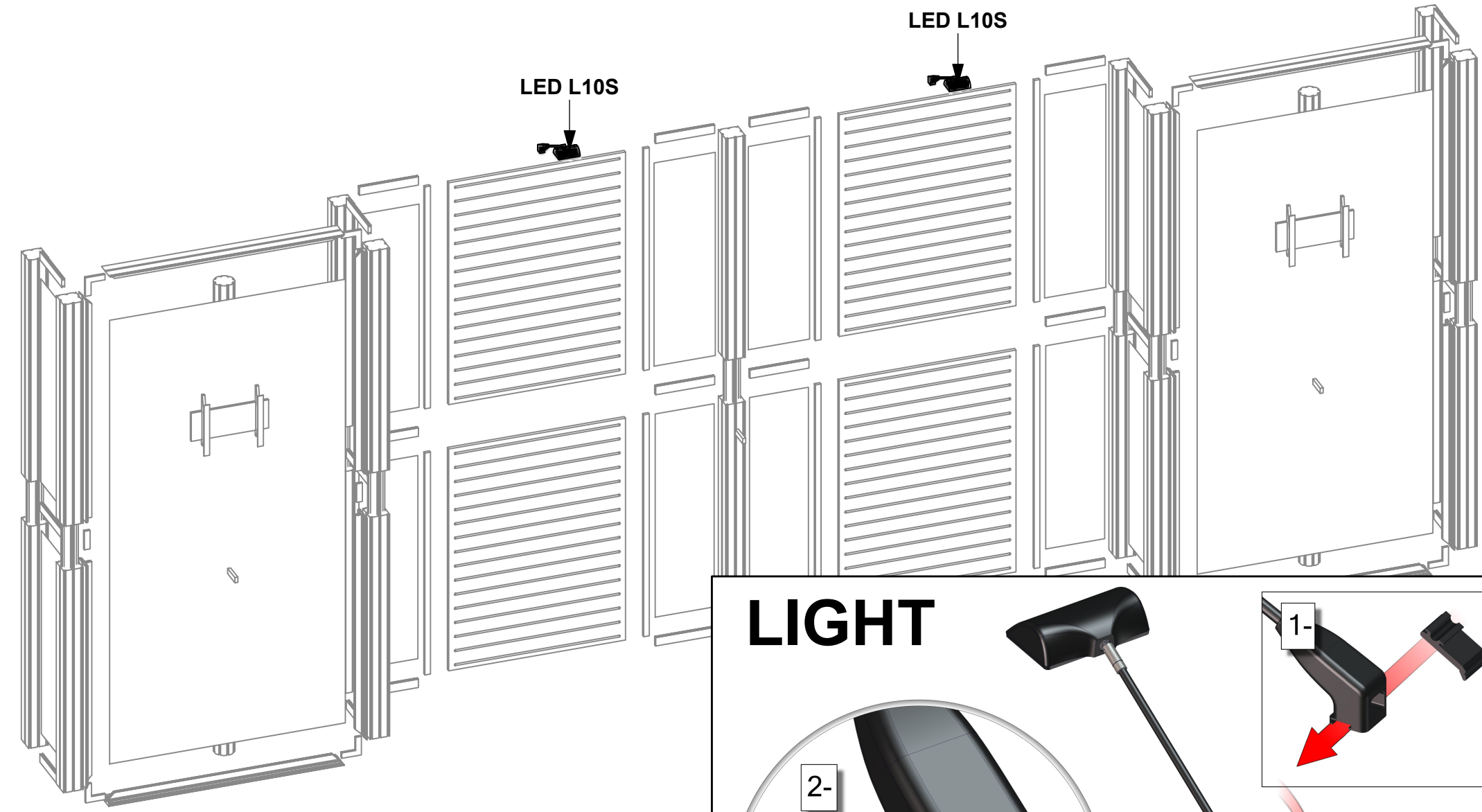

## LIGHT

**1-** Slide light clip onto the LIGHT.

**2-** Then slide the LIGHT into the channel at an angle and then gently lower down.

PANEL

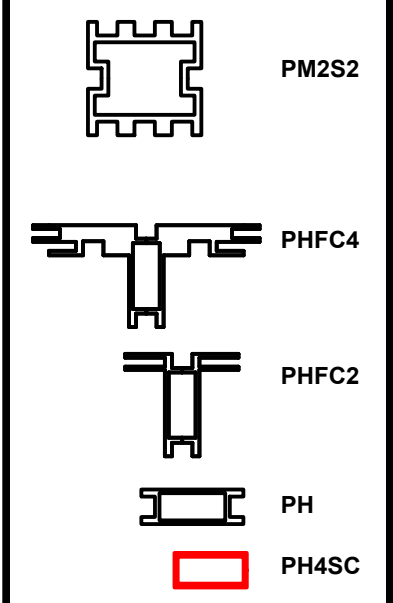

**HYBRID PRO RENTAL KIT**

Title: SET-UP INSTRUCTIONS

**R-LN-CU-06**  
**W/ SLIT**

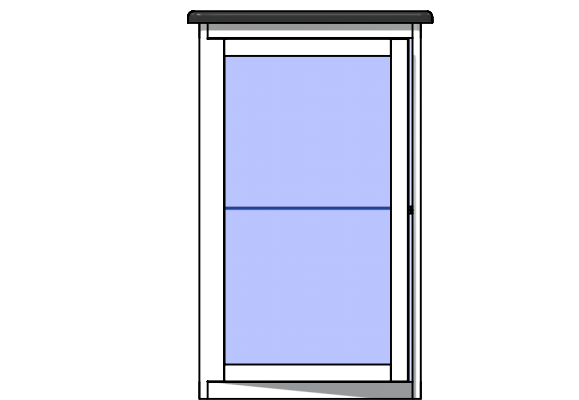
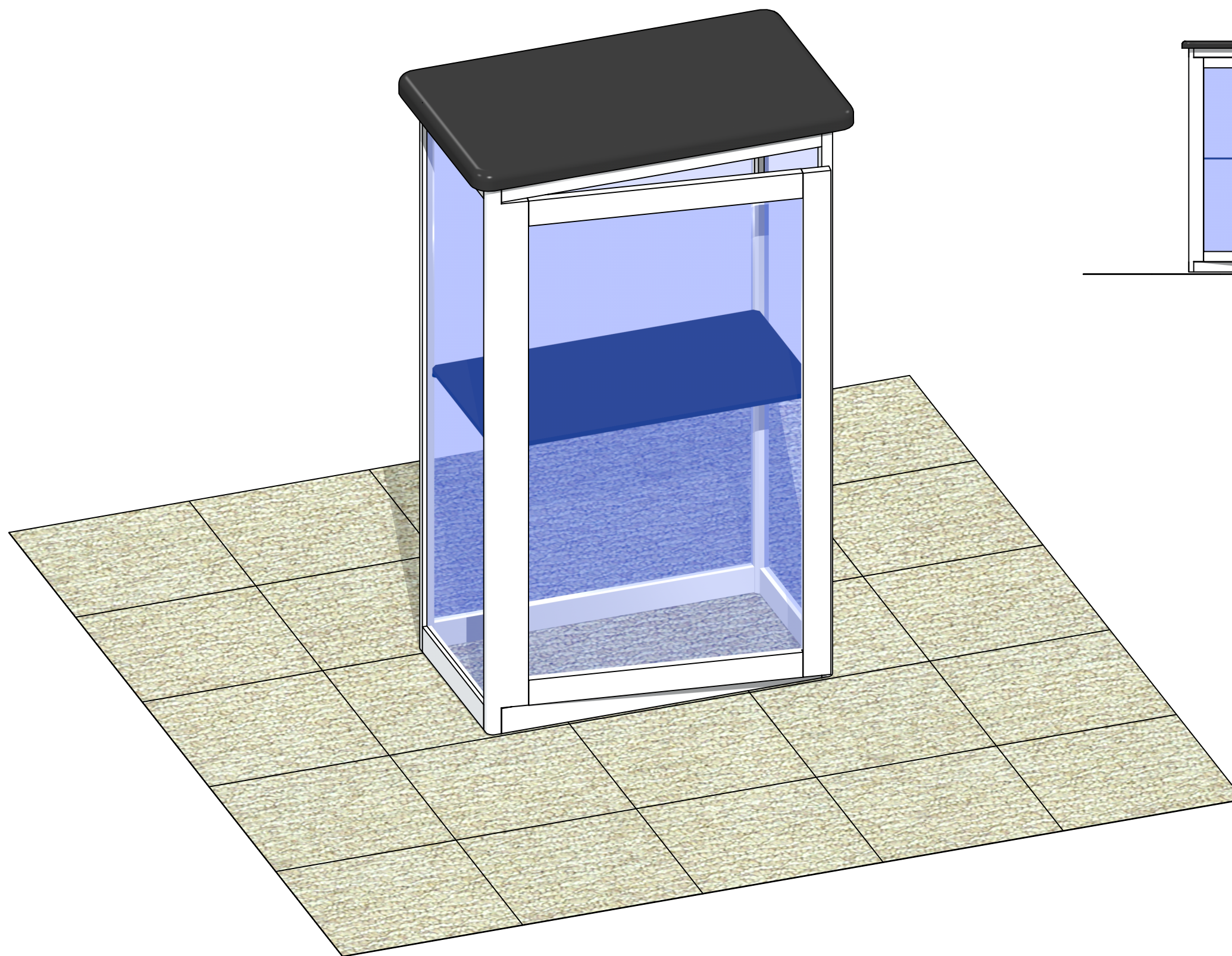

Code	#	Description
V-CU-CAB-01-S	3	292MM X 553 (11 1/2" X 21 3/4") INTERNAL SHELF FOR V-CU-CAB-01
R50	12	280MM (11") PH WITH SLIDE LOCK AT BOTH ENDS
R54	6	922MM X 292MM (36 5/16" X 11 1/2") SIDE SINTRA/FOAMEX
R53	3	581MM X 1000MM (22 7/8" X 39 3/8") FRONT FRAME W/GFX INFILL W/SLITS ON PH□□□□□
R52	3	581MM X 1000MM (22 7/8" X 39 3/8") CABINET DOOR W/GFX INFILL
V-SS1	12	SHELF SUPPORT
V-CW-CT-01	3	384MM X 646MM (15 1/8" X 25 7/16") HYBRID RECTANGLE TOP

# BOM

R-LN-CU-06  
W/ SLIT  
(3) UNITS

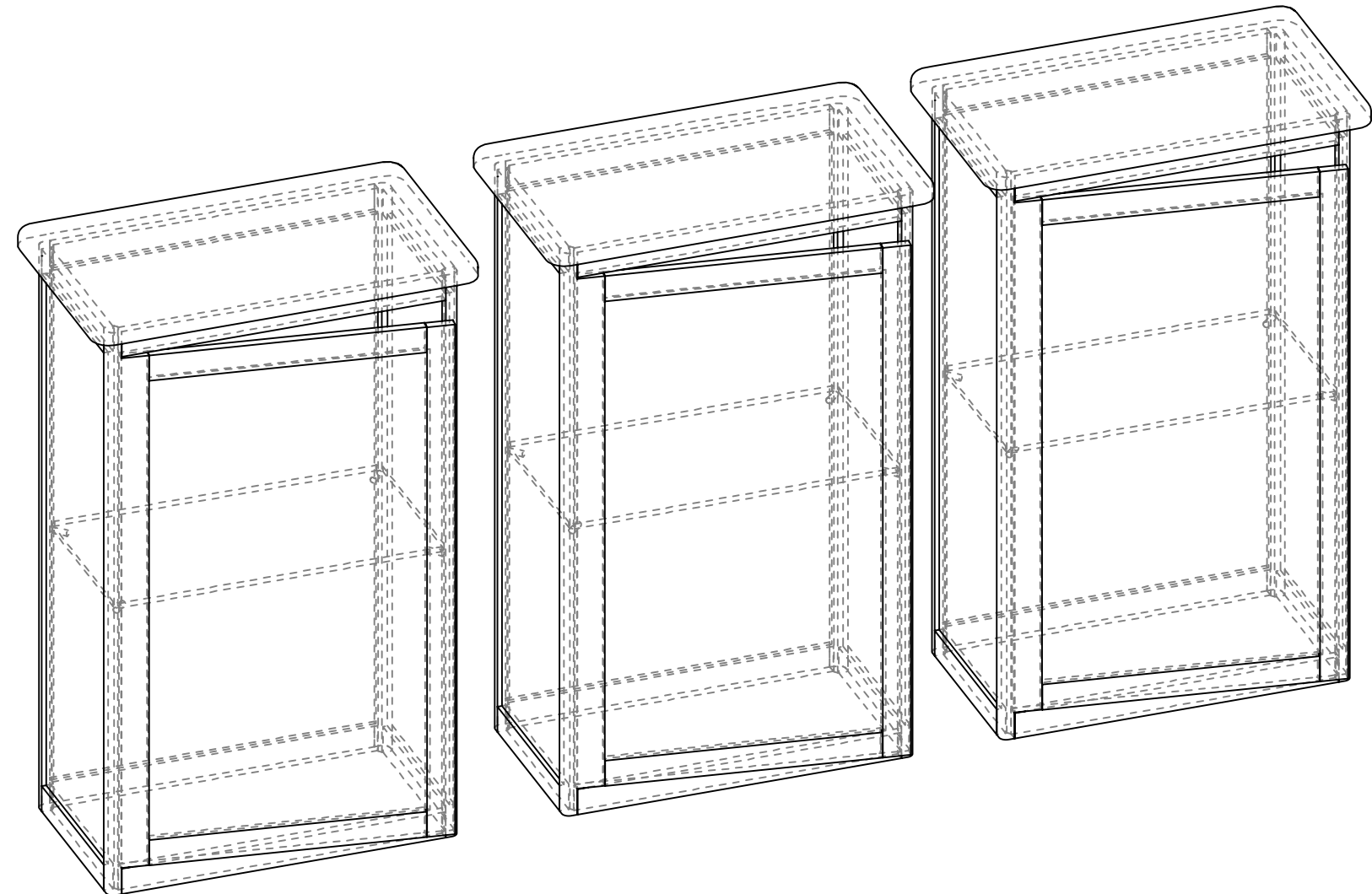
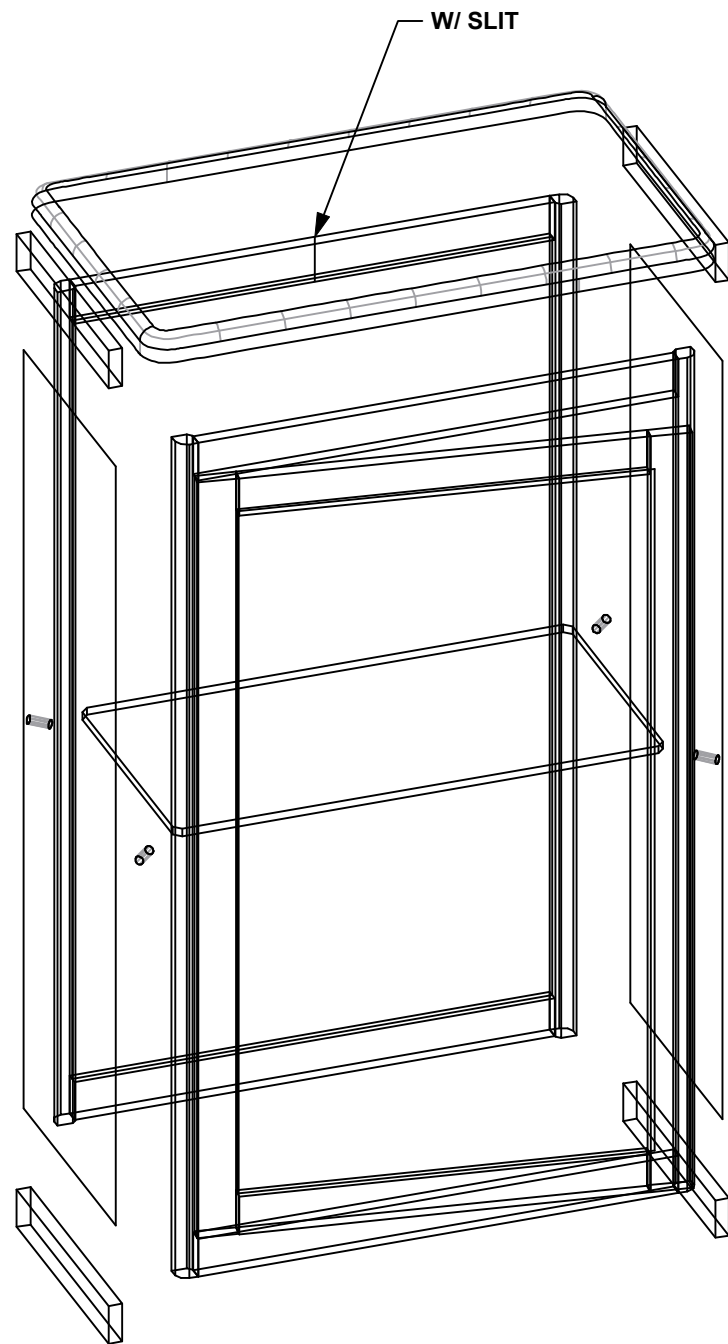
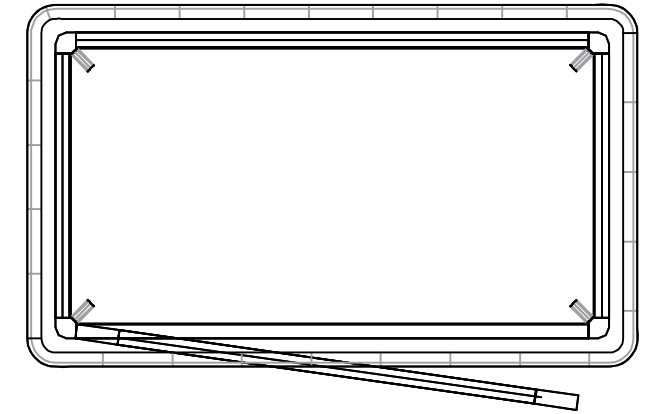

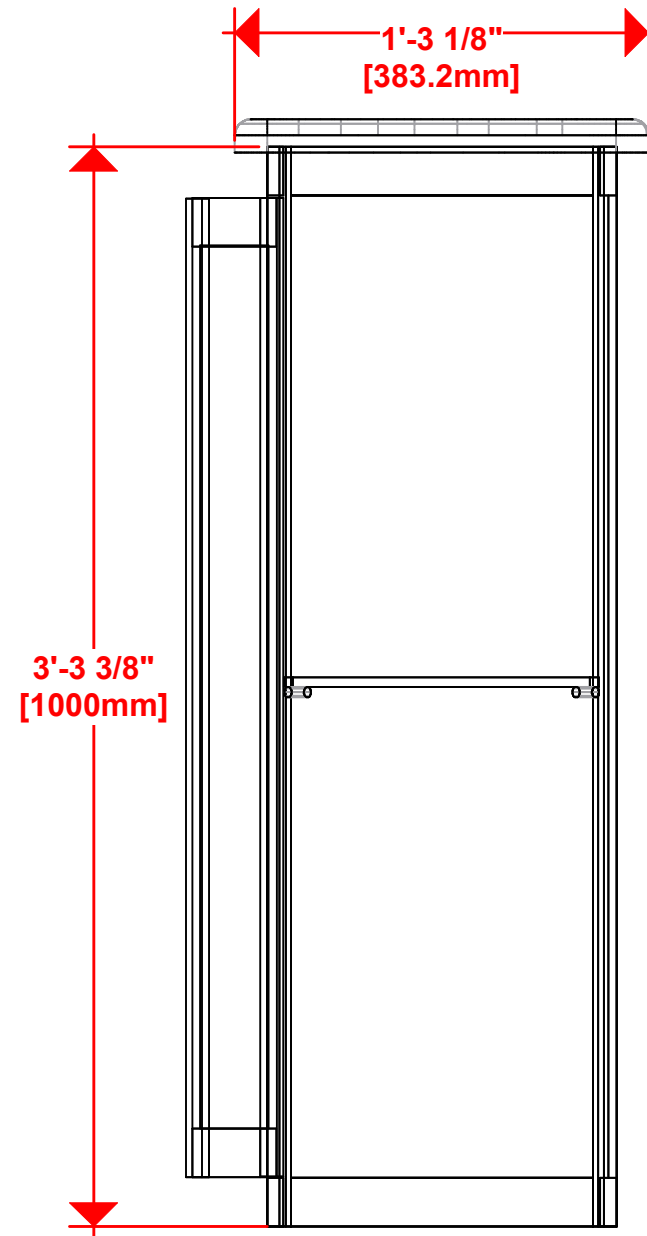
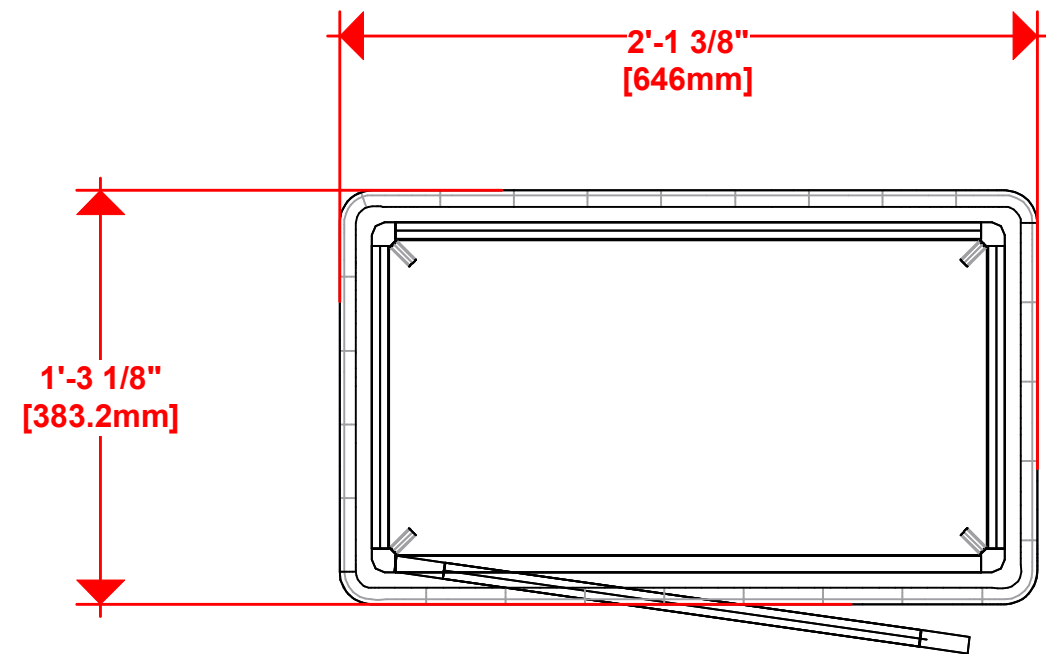

1. Redesign of this exhibit without approval by manufacturer may result in dangerous and unsafe structures. Manufacturer disclaims any responsibility for redesigned exhibits it does not approve in writing.

2. Parts and components such as panels and extrusions are manufactured to metric sizing. Where ever possible sizes have been noted in feet and inches as well as in metric. Below is the imperial to metric sizing table as reference. "Nominal" refers to approximate size.

- |                    |                                 |
|--------------------|---------------------------------|
| 2400mm = (94 1/2") | Phone Line / Fax                |
| 2100mm = (82 5/8") | Internet connection             |
| 1800mm = (70 7/8") | Outlet                          |
| 1500mm = (59")     | Main Drop (point of distrution) |
| 1200mm = (47 1/4") |                                 |
| 900mm = (35 1/2")  |                                 |
| 600mm = (23 5/8")  |                                 |
| 300mm = (11 7/8")  |                                 |
- Wire running under carpet

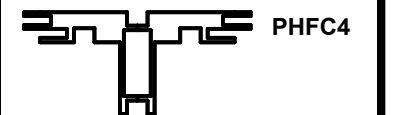

**HYBRID PRO RENTAL KIT**

Title: SET-UP INSTRUCTIONS

Code	#	Description
R50	2	280MM (11") PH WITH SLIDE LOCK AT BOTH ENDS
R53	1	581MM X 1000MM (22 7/8" X 39 3/8") FRONT FRAME W/GFX INFILL W/SLITS ON PH
R52	1	581MM X 1000MM (22 7/8" X 39 3/8") CABINET DOOR W/GFX INFILL

1. Redesign of this exhibit without approval by manufacturer may result in dangerous and unsafe structures. Manufacturer disclaims any responsibility for redesigned exhibits it does not approve in writing.

2. Parts and components such as panels and extrusions are manufactured to metric sizing. Where ever possible sizes have been noted in feet and inches as well as in metric. Below is the imperial to metric sizing table as reference. "Nominal" refers to approximate size.

2400mm = (94 1/2")	Phone Line / Fax
2100mm = (82 5/8")	Internet connection
1800mm = (70 7/8")	Outlet
1500mm = (59")	Main Drop (point of distrution)
1200mm = (47 1/4")	
900mm = (35 1/2")	
600mm = (23 5/8")	
300mm = (11 7/8")	

--- Wire running under carpet

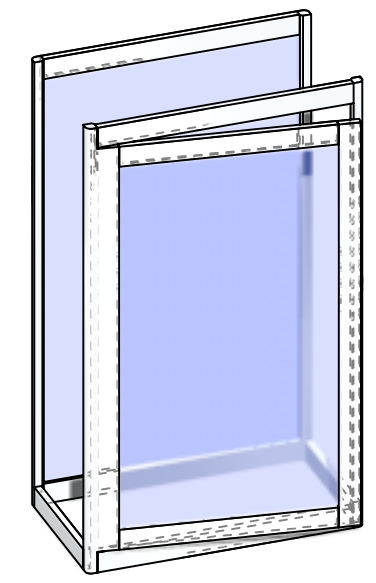
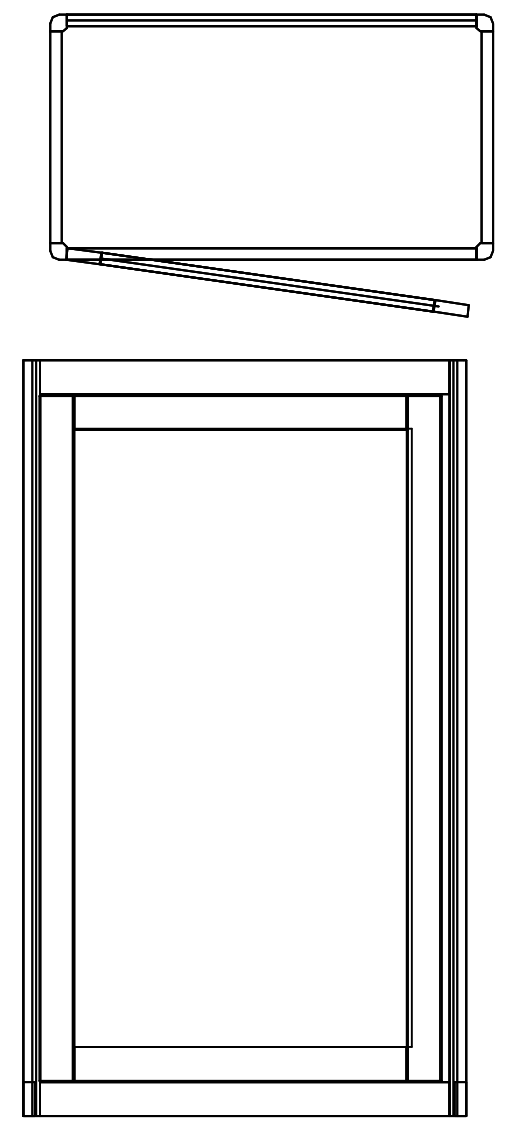
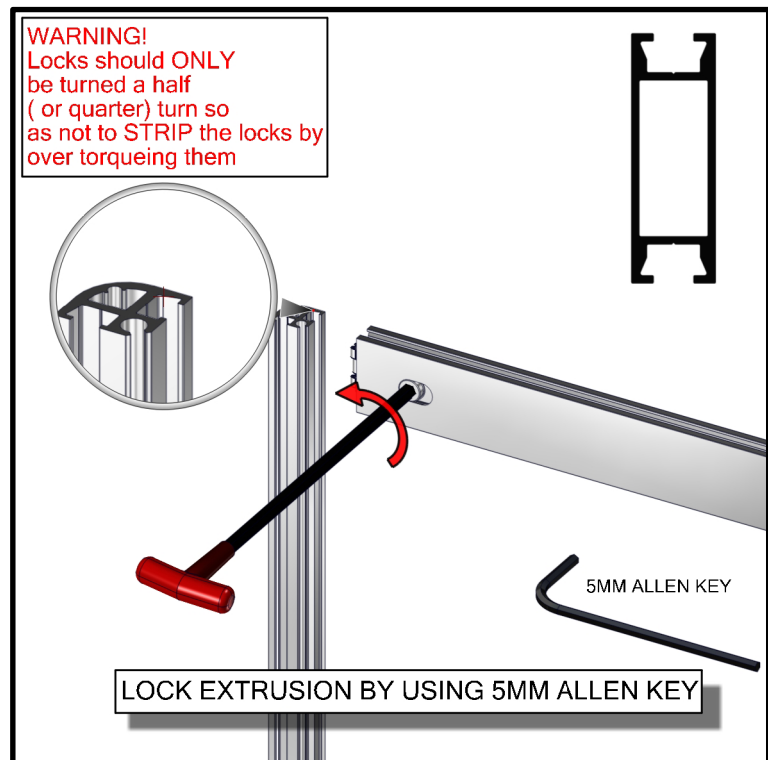
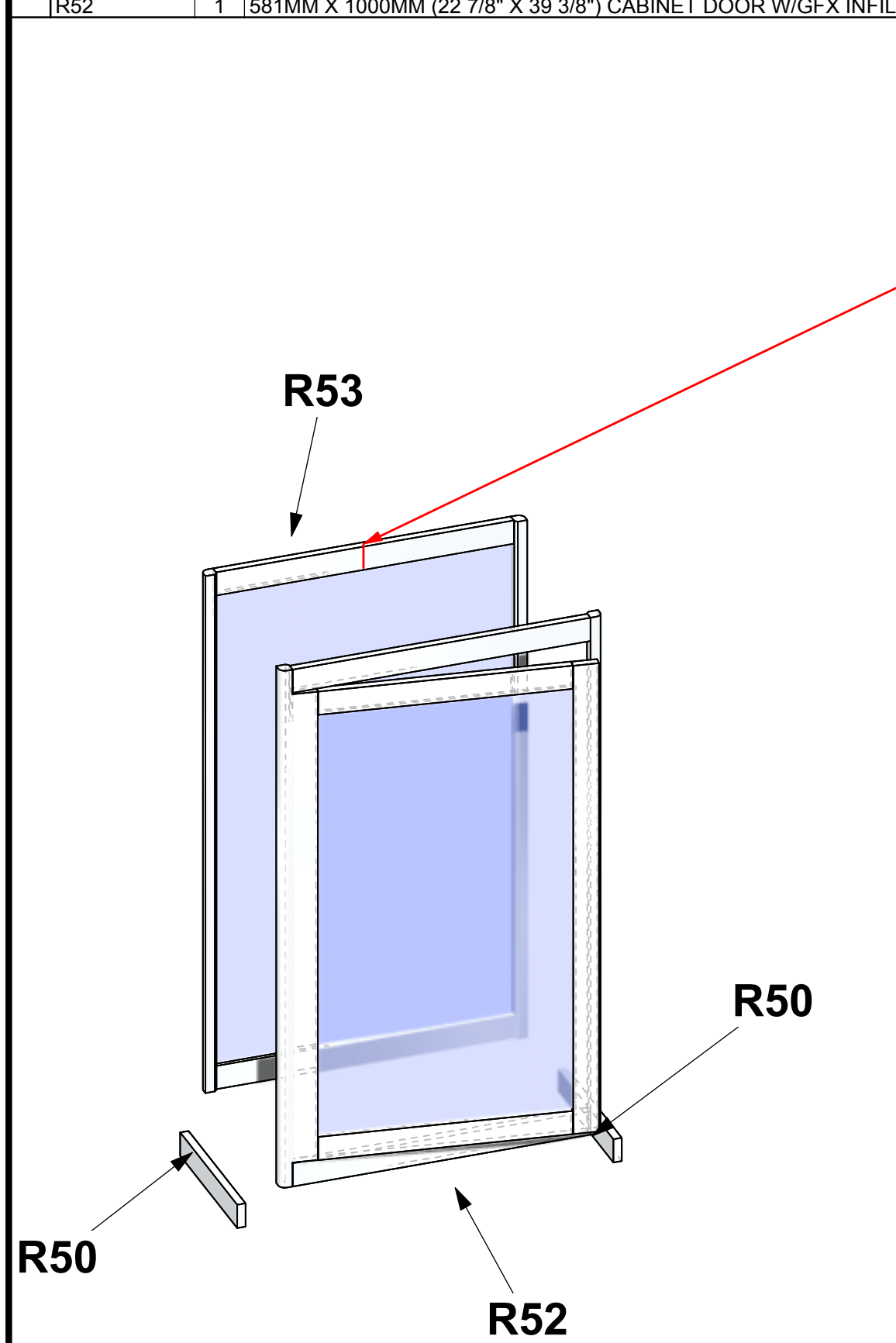
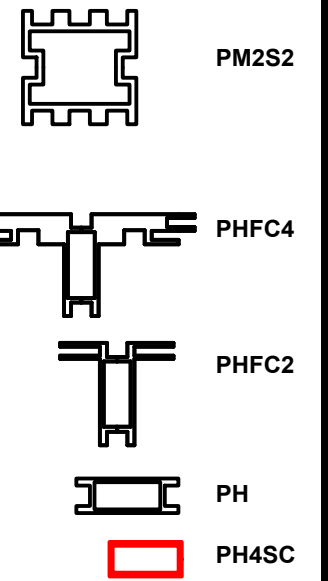

HYBRID PRO RENTAL KIT

Title: SET-UP INSTRUCTIONS

Code	#	Description
V-CU-CAB-01-S	1	292MM X 553 (11 1/2" X 21 3/4") INTERNAL SHELF FOR V-CU-CAB-01
R50	2	280MM (11") PH WITH SLIDE LOCK AT BOTH ENDS
R54	2	922MM X 292MM (36 5/16" X 11 1/2") SIDE SINTRA/FOAMEX
V-SS1	4	SHELF SUPPORT

1. Redesign of this exhibit without approval by manufacturer may result in dangerous and unsafe structures. Manufacturer disclaims any responsibility for redesigned exhibits it does not approve in writing.

2. Parts and components such as panels and extrusions are manufactured to metric sizing. Where ever possible sizes have been noted in feet and inches as well as in metric. Below is the imperial to metric sizing table as reference. \*Nominal" refers to approximate size.

2400mm = (94 1/2")	Phone Line / Fax
2100mm = (82 5/8")	Internet connection
1800mm = (70 7/8")	Outlet
1500mm = (59")	Main Drop (point of distrution)
1200mm = (47 1/4")	
900mm = (35 1/2")	
600mm = (23 5/8")	
300mm = (11 7/8")	

--- Wire running under carpet

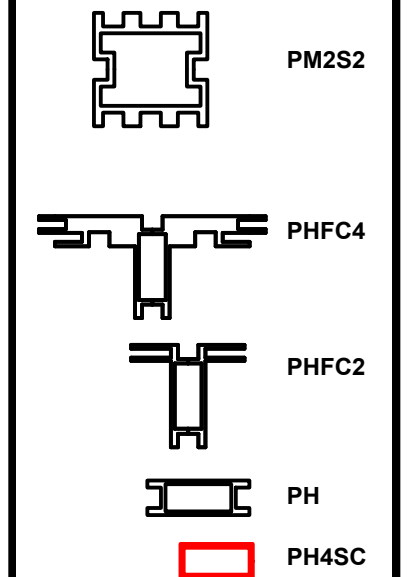
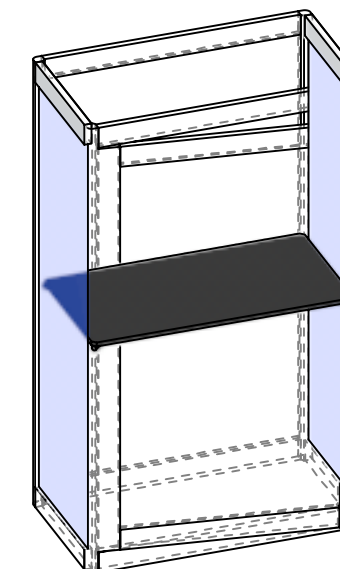
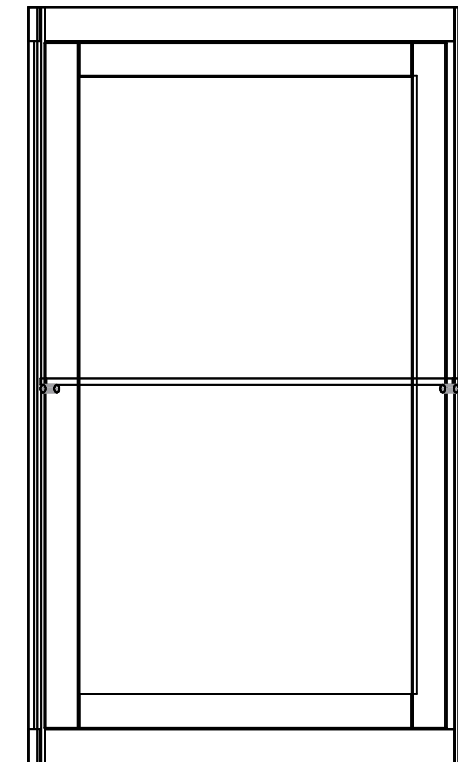
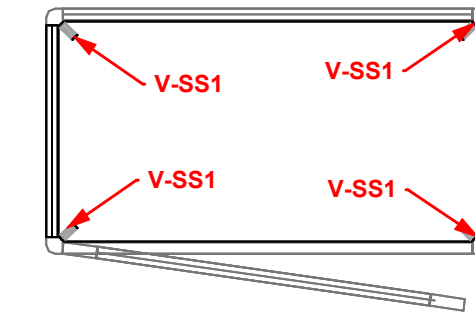
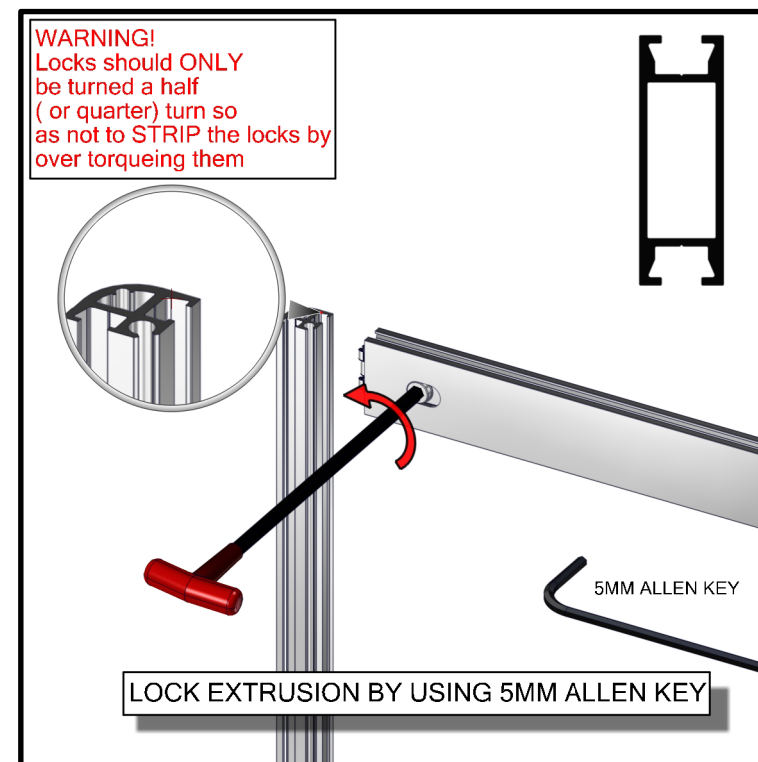
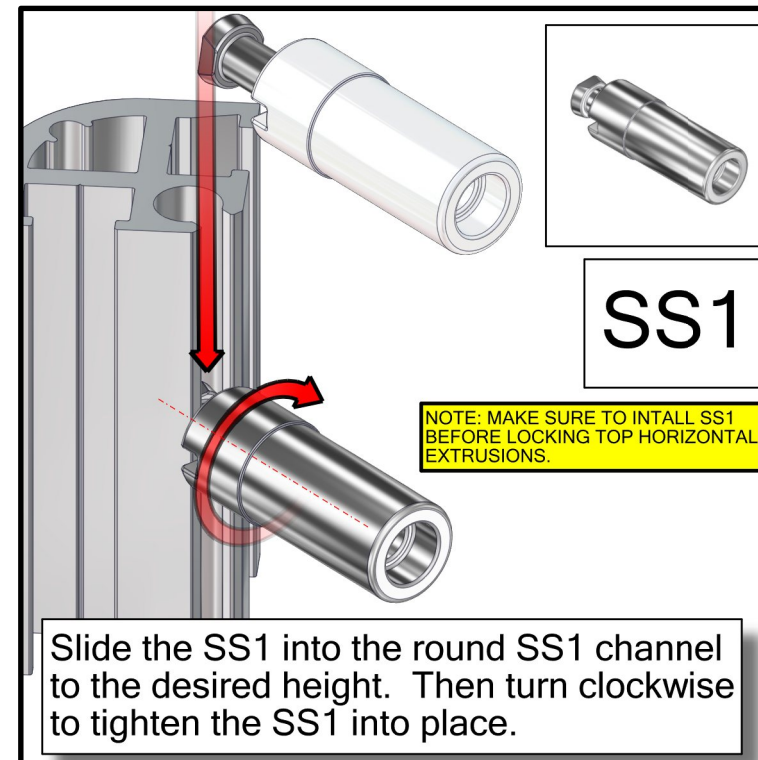
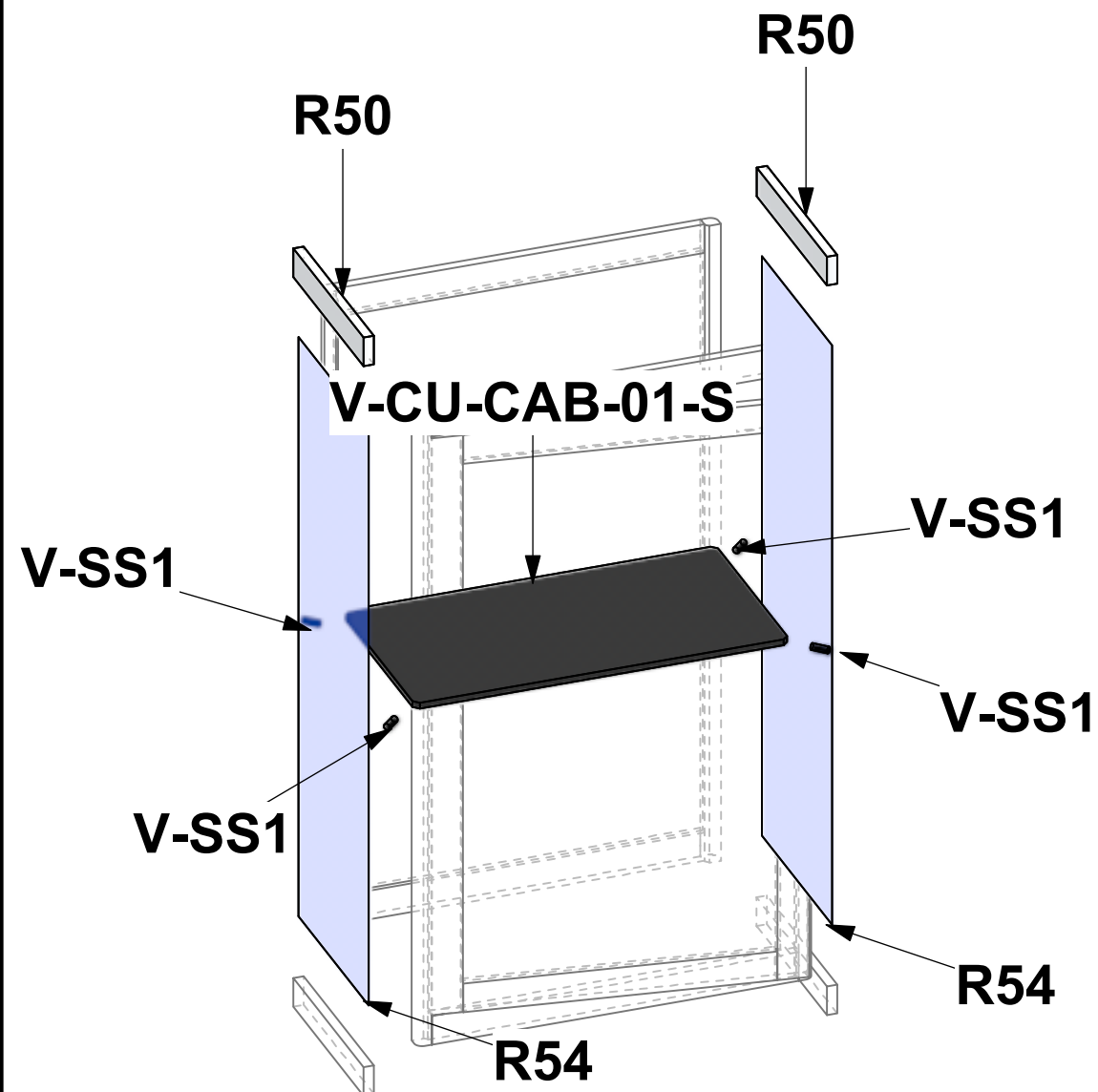

HYBRID PRO RENTAL KIT

Title: SET-UP INSTRUCTIONS



Code	#	Description
V-CW-CT-01	1	384MM X 646MM (15 1/8" X 25 7/16") HYBRID RECTANGLE TOP

1. Redesign of this exhibit without approval by manufacturer may result in dangerous and unsafe structures. Manufacturer disclaims any responsibility for redesigned exhibits it does not approve in writing.

2. Parts and components such as panels and extrusions are manufactured to metric sizing. Where ever possible sizes have been noted in feet and inches as well as in metric. Below is the imperial to metric sizing table as reference. "Nominal" refers to approximate size.

- 2400mm = (94 1/2") Phone Line / Fax
- 2100mm = (82 5/8") Internet connection
- 1800mm = (70 7/8")
- 1500mm = (59") Outlet
- 1200mm = (47 1/4")
- 900mm = (35 1/2") Main Drop (point of distrution)
- 600mm = (23 5/8")
- 300mm = (11 7/8")

--- Wire running under carpet

**V-CW-CT-01**

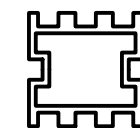
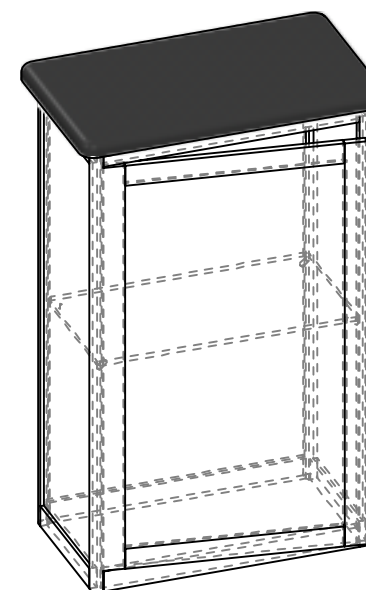
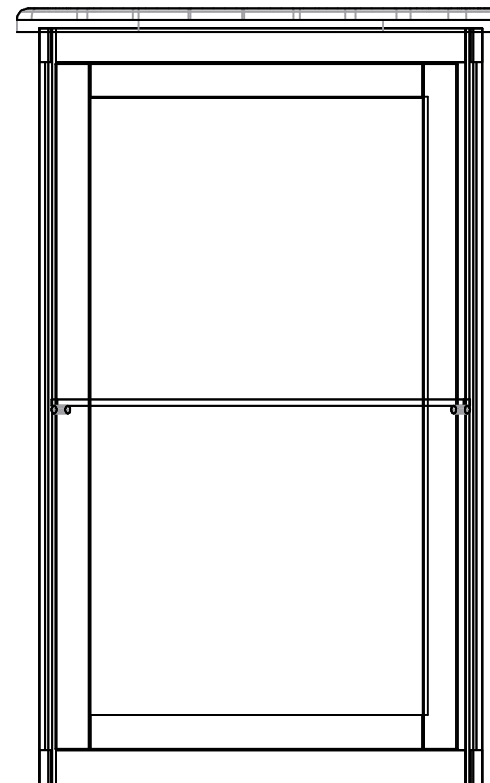
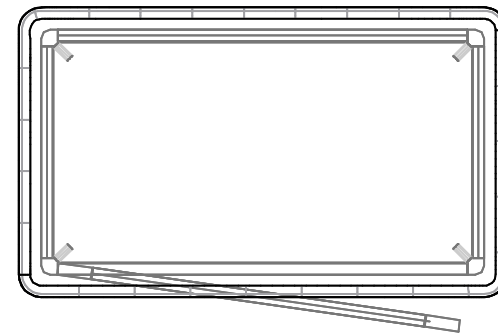
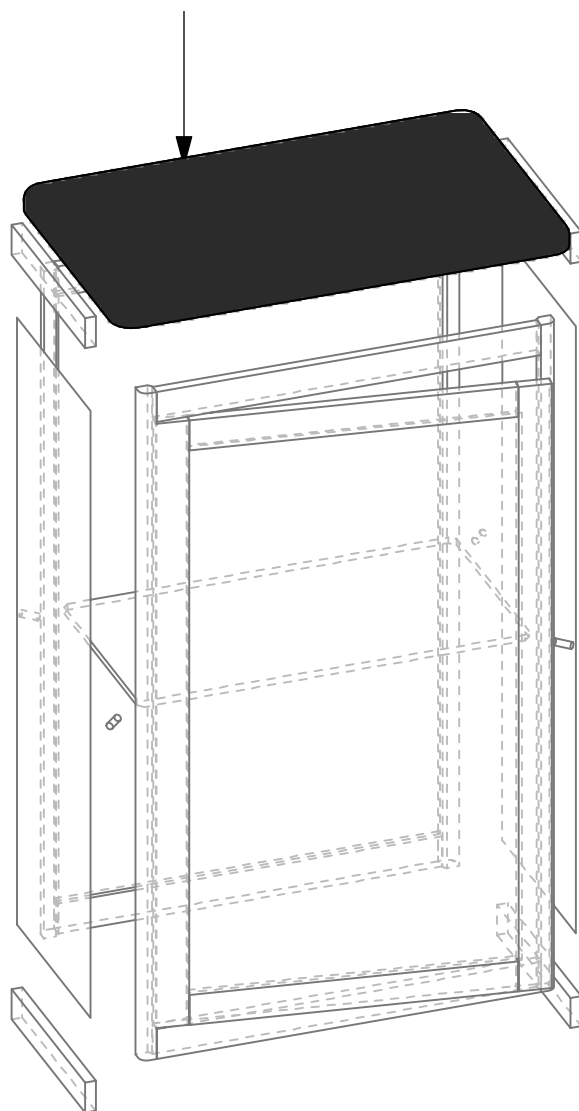

PM2S2

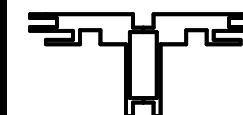

PHFC4

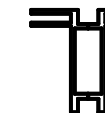

PHFC2



PH



PH4SC

**HYBRID PRO RENTAL KIT**

Title: SET-UP INSTRUCTIONS

# **PACKING INSTRUCTIONS**



2



4



1



3

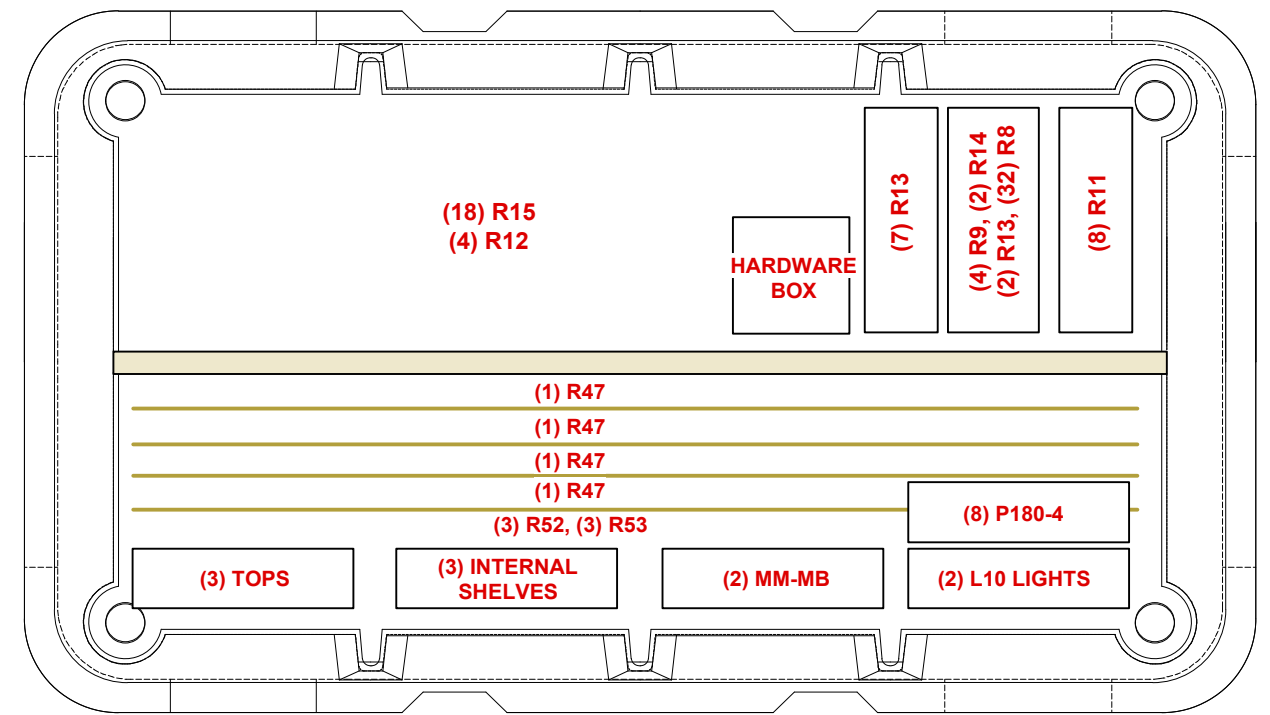

# CASE # 1

<b>LEGEND</b>		GREY FOAM FOLDED TO FILL EMPTY SPACES OR USED AS PROTECTION
		1/8" CARDBOARD SPACER (PUT IN BETWEEN EVERY PANEL)
		DIVIDER
		1/4" WHITE FOAM (USED AS PROTECTION DOOR PANELS W/ LOCKS)

INTERNAL DIMS 49"L X 24.5"W X 51"H

EXTERNAL DIMS 59"L X 34"W X 57"H

**SCRATE**