

Hybrid Pro Modular Kit 03

HP-K-03

Hybrid Pro™ Modular exhibits and counters are a perfect solution for the serious exhibitor. Exhibits feature heavy-duty aluminum extrusion frames and push-fit fabric graphics. Count on making an unforgettable impact with Hybrid Pro Modular exhibit kits, counters, and accessories.



* foreground counter not included

features and benefits:

- Silver aluminum extrusion frame
- Illuminated SEG push-fit graphic panel with interior top and bottom LED lighting
- Single-sided SEG dye-sublimated push-fit fabric graphics
- Easy step-by-step instructions
- Kit includes frame, side/top white accent, two fabric graphic panels, one illuminated graphic panel, one pillowcase fabric graphic, one backwall counter, one medium monitor mount, two molded OCH2 cases and one wood crate
- Lifetime hardware warranty against manufacturer defects

dimensions:

Hardware	Graphic
<p>Assembled unit: 111.63" w x 94.75" h x 30.38" d 2835.4mm(w) x 2406.65mm(h) x 771.65mm(d)</p> <p>Backwall Counter: 21.75" w x 38" h x 17.75" d approx. 552.45mm(w) x 965.2mm(h) x 450.85mm(d)</p> <p>* Laminate cabinet with locking storage door and custom side/top laminate accent panel</p>	<p>Total visual area: Panel A: 35.3" w x 82.54" h Panel B: 23.49" w x 70.73" h Panel C (backlit): 47.125" w x 94.375" h Panel D (double sided pillowcase): 151.68" w x 17.71" h Top (outside D): 61.93" w x 17.71" h Top (inside D): 60.722" w x 17.71" h Side 1 (outside D): 90" w x 17.71" h Side 2 (inside D): 88.891" w x 17.71" h</p> <p>*We recommend that the inside be a pattern or solid color. Please consider obstructions and spaces created by the extrusions when designing graphics. Be sure to include a 2" bleed around the perimeter of panel B.</p> <p>Refer to related graphic templates for more information</p> <p>Visit: www.exhibitors-handbook.com/graphic-templates</p>
<p>Shipping</p> <p>Shipping dimensions - ships in 3 cases: 2 OCH2 cases: 52" l x 30" w x 14" h 1320.8mm(l) x 762mm(w) x 355.6mm(h)</p> <p>1 WOODCRATE: 48" l x 30" w x 27" h 1219.2mm(l) x 762mm(w) x 685.8mm(h)</p> <p>Approximate shipping weight (entire kit): 396 lbs / 180 kgs</p>	

additional information:

Graphic material: Dye-sublimated fabric

Medium monitor bracket holds 26-40" LCD, max weight: 50 lbs / 22.68 kgs

Max counter weight = 50 lbs / 22.68 kgs

*LCD monitor not included

*Foreground counter not included in purchased/rental kit

Laminate counter color options:

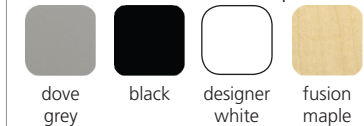

We are continually improving and modifying our product range and reserve the right to vary the specifications without prior notice. All dimensions and weights quoted are approximate and we accept no responsibility for variance. E&OE. See Graphic Templates for graphic bleed specifications.

R-HP-K-03

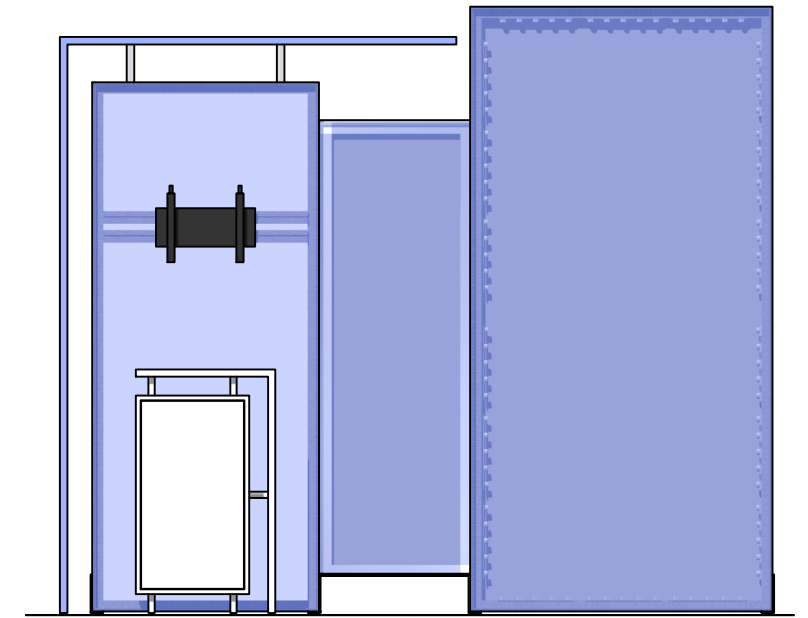
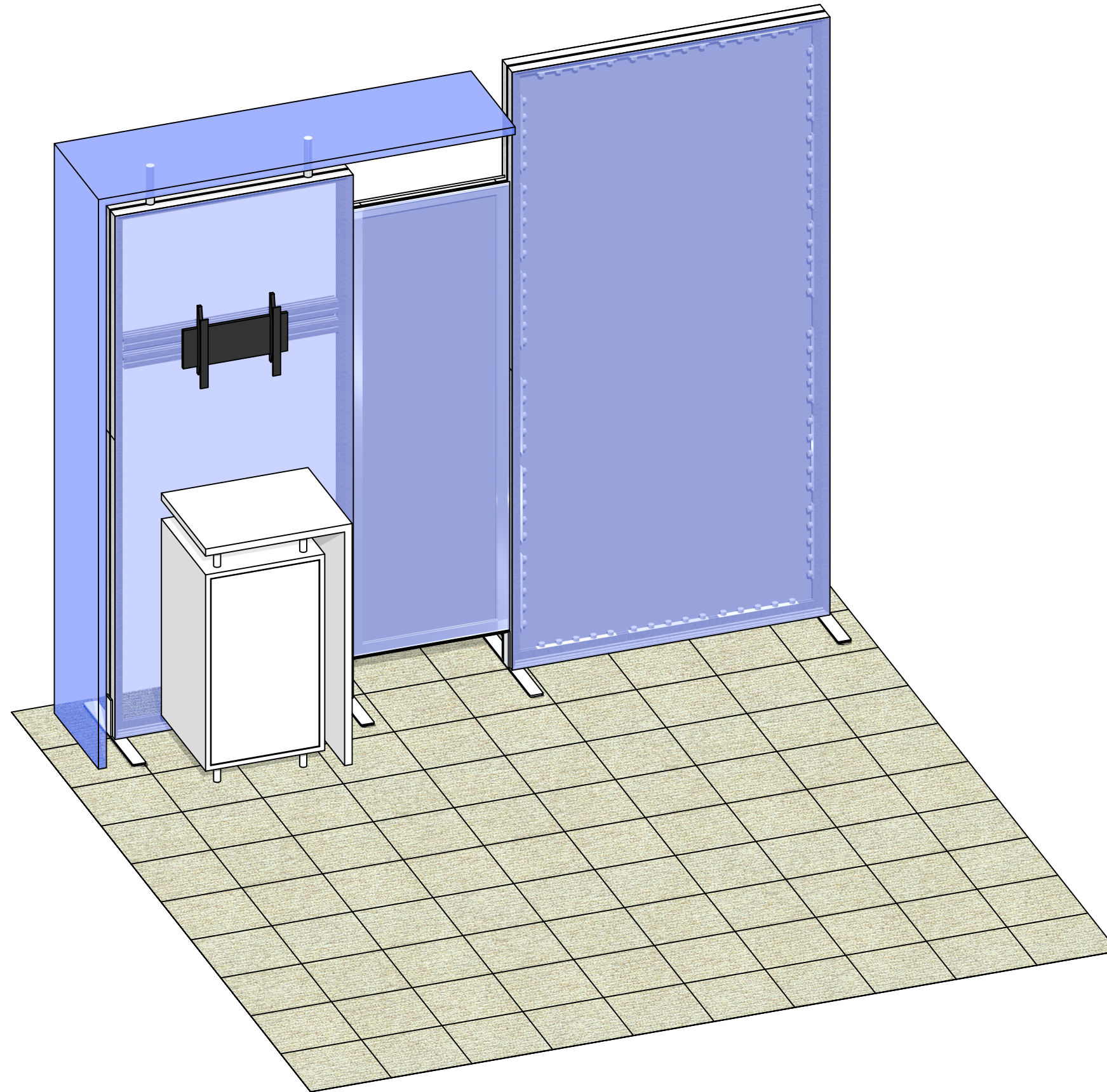

Code	#	Description
SW-FOOT	4	SMARTWALL SUPPORT FOOT
R10	6	1200MM (47.24") PHFC4 EXTRUSION WITH MITRE CUT 1 END FOR CB9 ONE END-IB2 HOLES ONE END
CB9	8	CB9 CORNER BRACKET
IB2	6	INLINE BRACKET CONNECTOR
R9	2	1200MM (47.24") PHFC4 EXTRUSION WITH MITRE CUT BOTH ENDS
R41	2	900MM (35.43") PHFC4 EXTRUSION WITH MITRE CUT 1 END FOR CB9 ONE END-IB2 HOLES ONE END
R26	2	900MM (35.43") PHFC4 EXTRUSION WITH MITRE CUT BOTH ENDS
GRAPHIC A	1	82.67"H X 35.43"W SINGLE SIDED DYESUB GRAPHIC W/FCE-2 ON PERIMETER
GRAPHIC C	1	94.5"H X 47.25"W BACKLIT DYESUB GRAPHIC W/FCE-2 ON PERIMETER
MM-MB	1	MEDIUM MONITOR BRACKET FOR MONITORS 15"-40"
UNPRINTED C	1	94.5"H X 46.75"W WHITE FABRIC W/FCE-2 ON PERIMETER
R42	2	810MM (31.89") 50MM50MM PM2S 4 WAY ROUND EXTRUSION
GRAPHIC B	1	70.86"H X 23.62"W SINGLE SIDED DYESUB GRAPHIC W/FCE-2 ON PERIMETER
SO-1 1/4 X 3	9	1 1/4" X 3" L STANDOFF ASSEMBLY
CUST CT	1	CUST CT
CUST FS	1	APPROX. 62" W X 90" H X 18" D CUSTOM L-SHAPED FABRIC STRUCTURE - FRAME ONLY
LED-WHT-DB-300	18	300MM (11.81") LENGTH LED LIGHTS FOR DIRECTIONAL BACKLIGHT
R55	2	510MM (20.08") PHFC2 EXTRUSION WITH LOCKS 2 ENDS
CB9-S	4	50MM SQUARE PHCF2 CORNER BRACKET
R43	4	855MM (33.66") PHFC2 EXTRUSION WITH LOCKS 2 ENDS WITH SIDE CAM LOCKS

BOM

R-HP-K-03

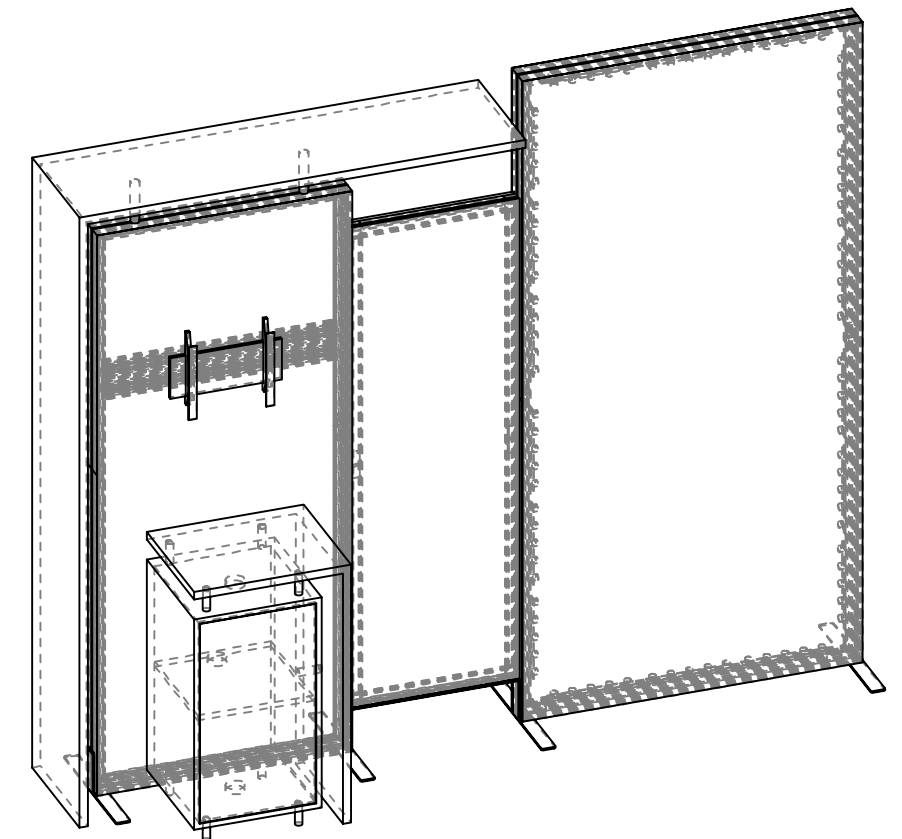
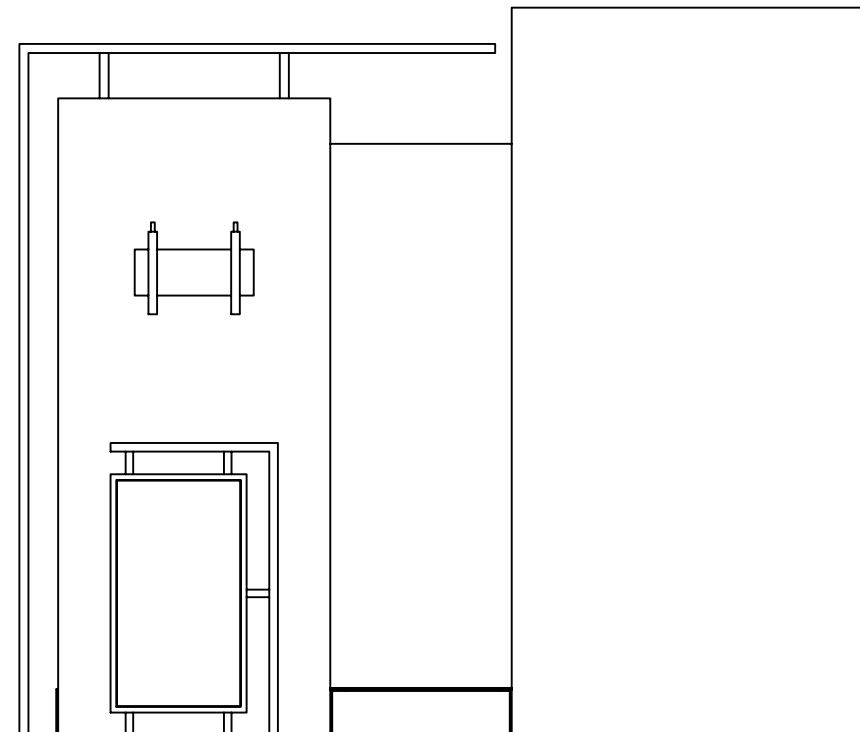
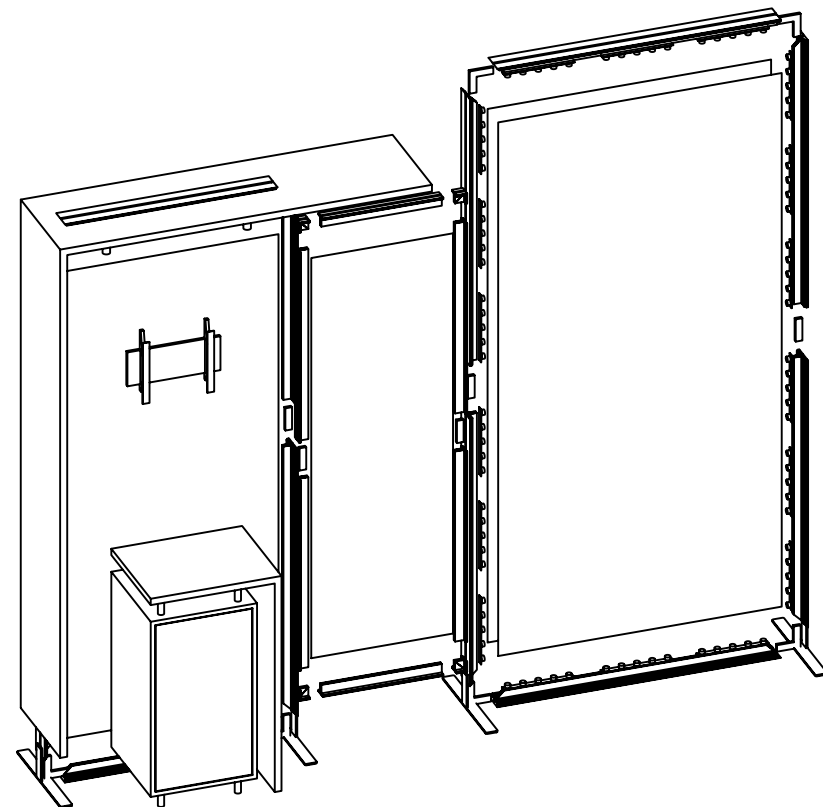
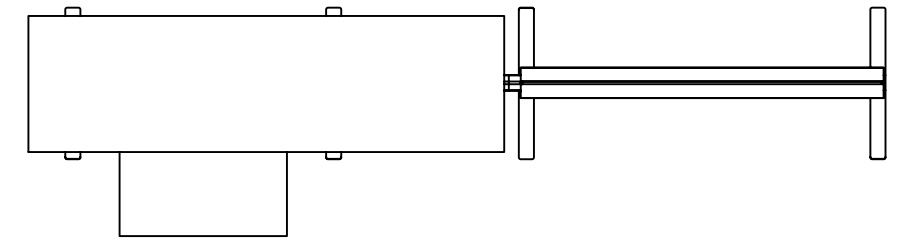

1. Redesign of this exhibit without approval by manufacturer may result in dangerous and unsafe structures. Manufacturer disclaims any responsibility for redesigned exhibits it does not approve in writing.

2. Parts and components such as panels and extrusions are manufactured to metric sizing. Where ever possible sizes have been noted in feet and inches as well as in metric. Below is the imperial to metric sizing table as reference. "Nominal" refers to approximate size.

2400mm = (94 1/2")	▼ Phone Line / Fax
2100mm = (82 5/8")	▼ Internet connection
1800mm = (70 7/8")	▼ Outlet
1500mm = (59")	▼ Main Drop (point of distrution)
1200mm = (47 1/4")	
900mm = (35 1/2")	
600mm = (23 5/8")	
300mm = (11 7/8")	

--- Wire running under carpet

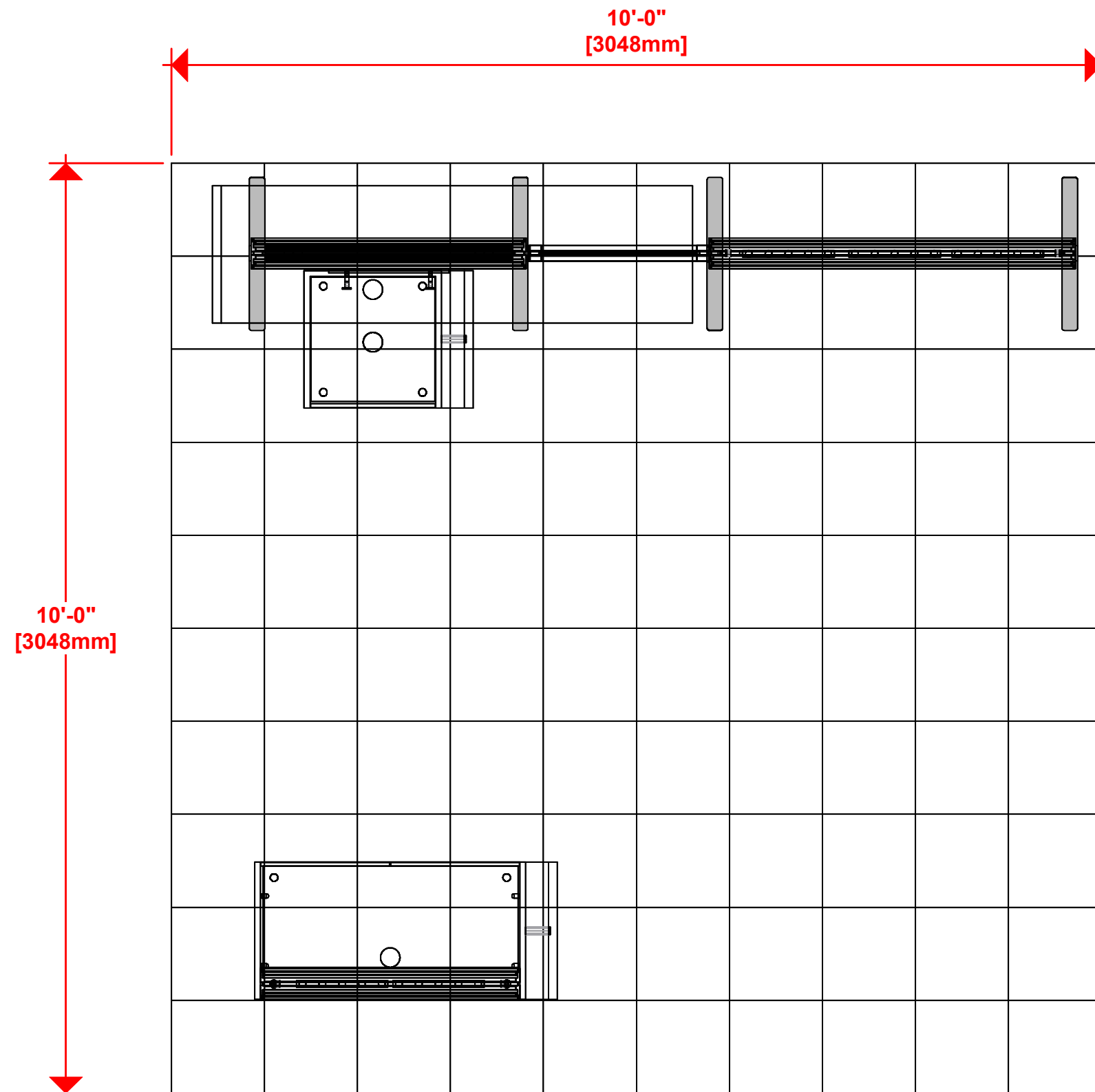

(18) LED-WHT-DB-300 LIGHTS = 24W PER STICK

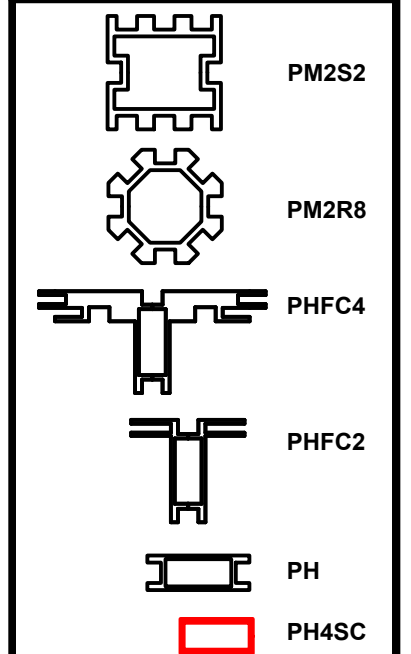

HYBRID PRO RENTAL KIT

Title: SET-UP INSTRUCTIONS

LED-WHT-DB-300 LIGHTS

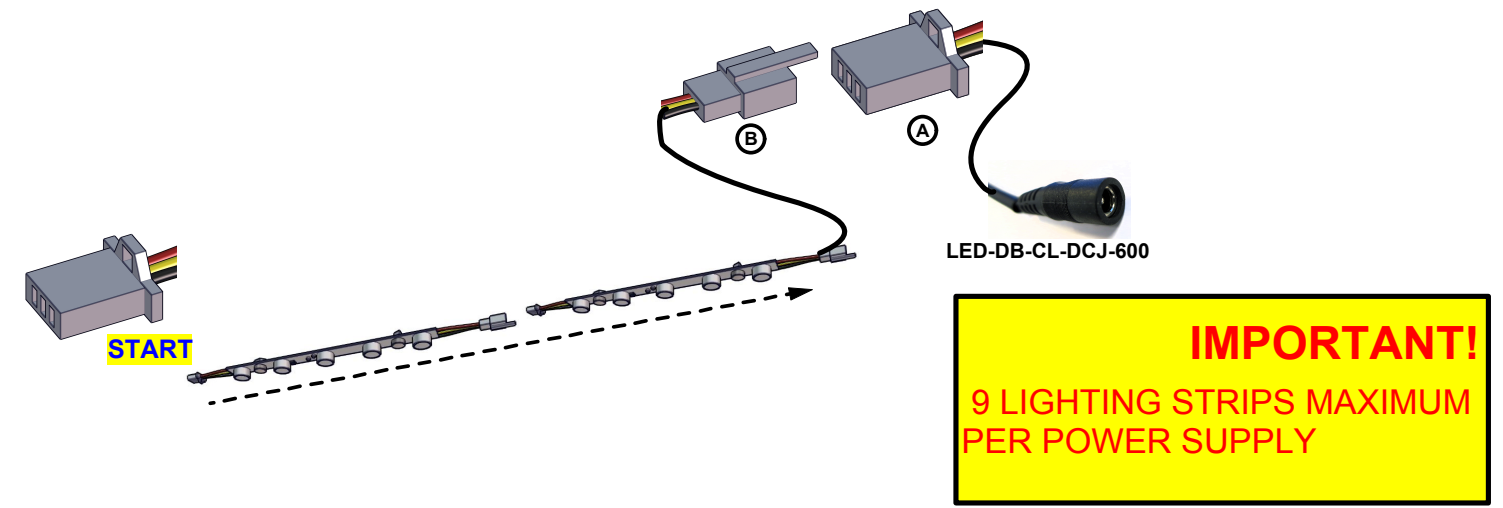
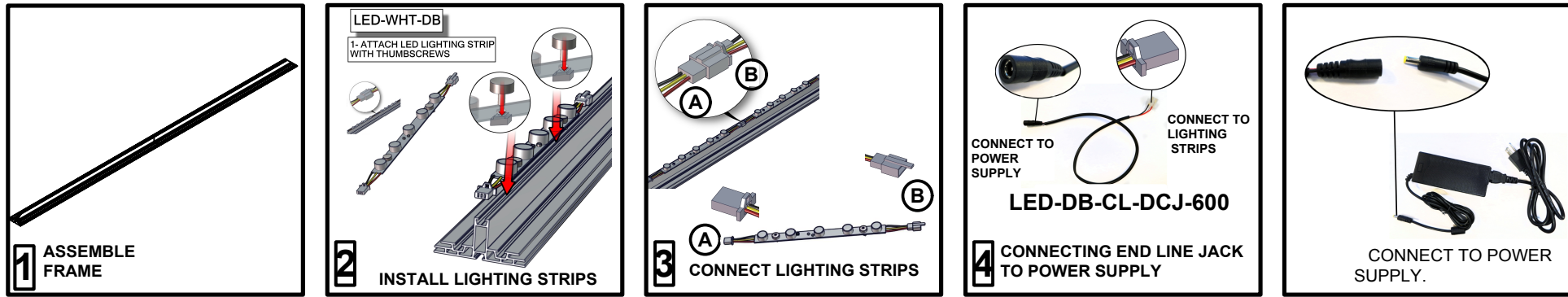

END LINE CONNECTORS & POWER SUPPLY

EXTENSION CORDS

HARDWARE

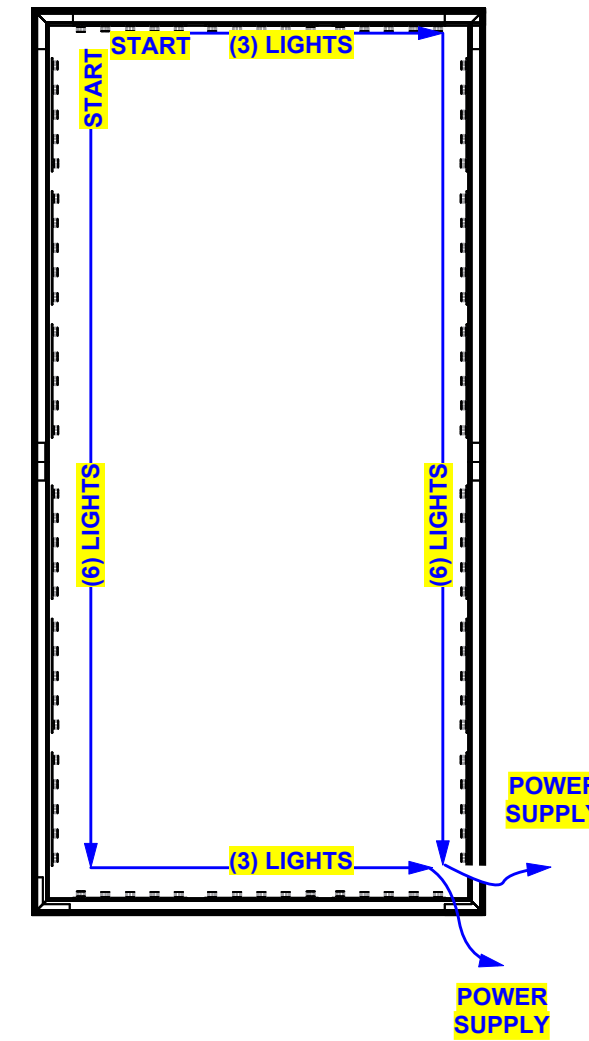
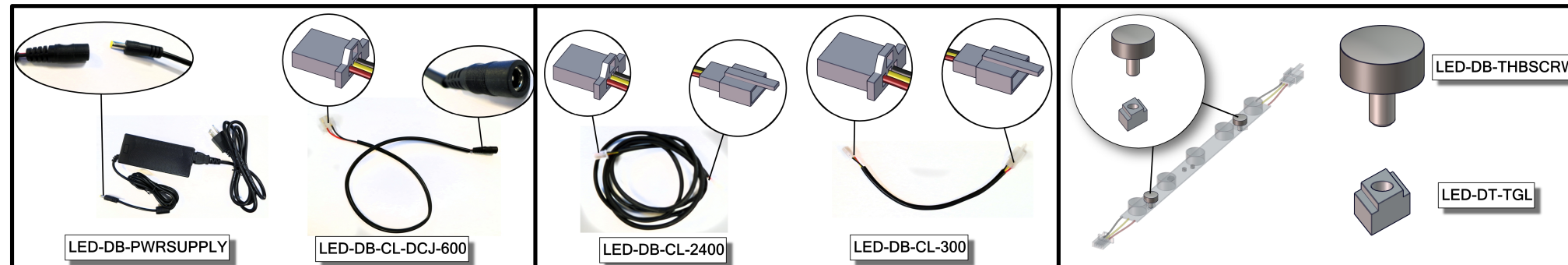

1. Redesign of this exhibit without approval by manufacturer may result in dangerous and unsafe structures. Manufacturer disclaims any responsibility for redesigned exhibits it does not approve in writing.

2. Parts and components such as panels and extrusions are manufactured to metric sizing. Where ever possible sizes have been noted in feet and inches as well as in metric. Below is the imperial to metric sizing table as reference. "Nominal" refers to approximate size.

2400mm = (94 1/2")	Phone Line / Fax
2100mm = (82 5/8")	Internet connection
1800mm = (70 7/8")	Outlet
1500mm = (59")	Main Drop (point of distrution)
1200mm = (47 1/4")	
900mm = (35 1/2")	
600mm = (23 5/8")	
300mm = (11 7/8")	

--- Wire running under carpet

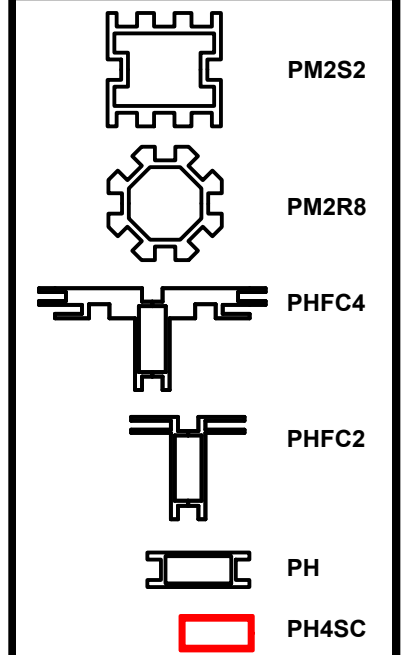

HYBRID PRO RENTAL KIT

Title: SET-UP INSTRUCTIONS

Code	#	Description
R10	4	1200MM (47.24") PHFC4 EXTRUSION WITH MITRE CUT 1 END FOR CB9 ONE END-IB2 HOLES ONE END
CB9	4	CB9 CORNER BRACKET
IB2	2	INLINE BRACKET CONNECTOR
R9	2	1200MM (47.24") PHFC4 EXTRUSION WITH MITRE CUT BOTH ENDS
LED-WHT-DB-300	18	300MM (11.81") LENGTH LED LIGHTS FOR DIRECTIONAL BACKLIGHT

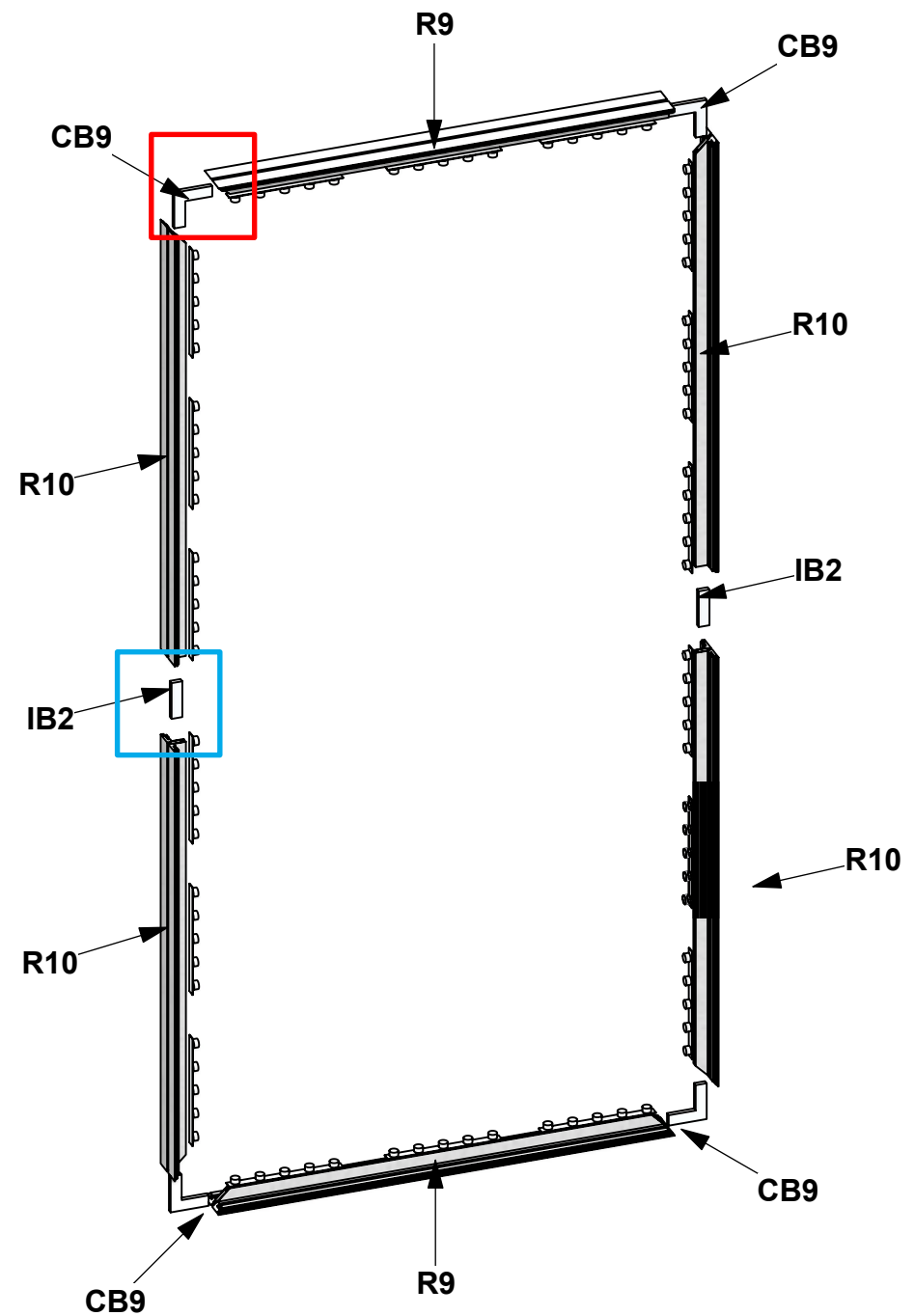
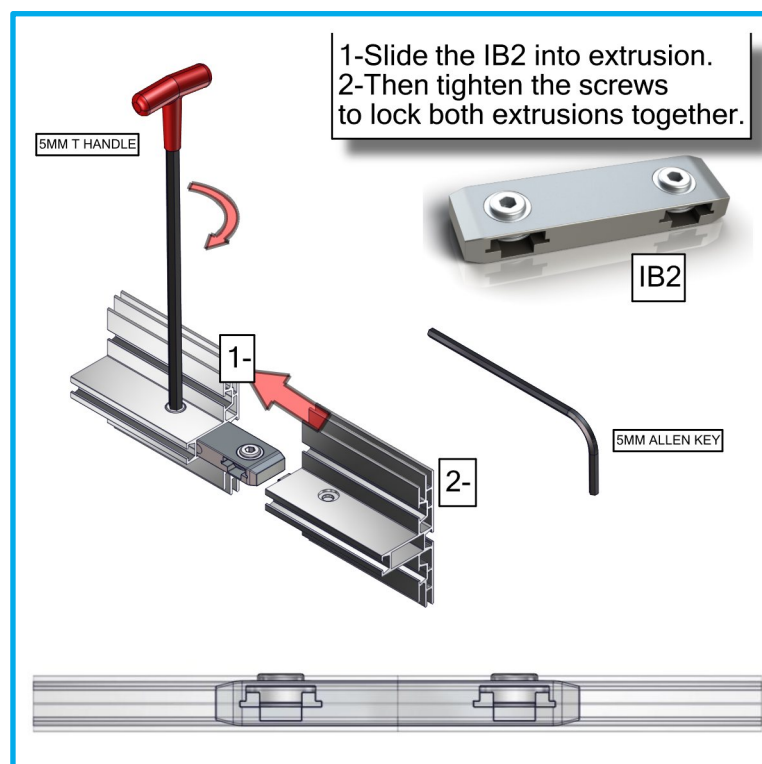
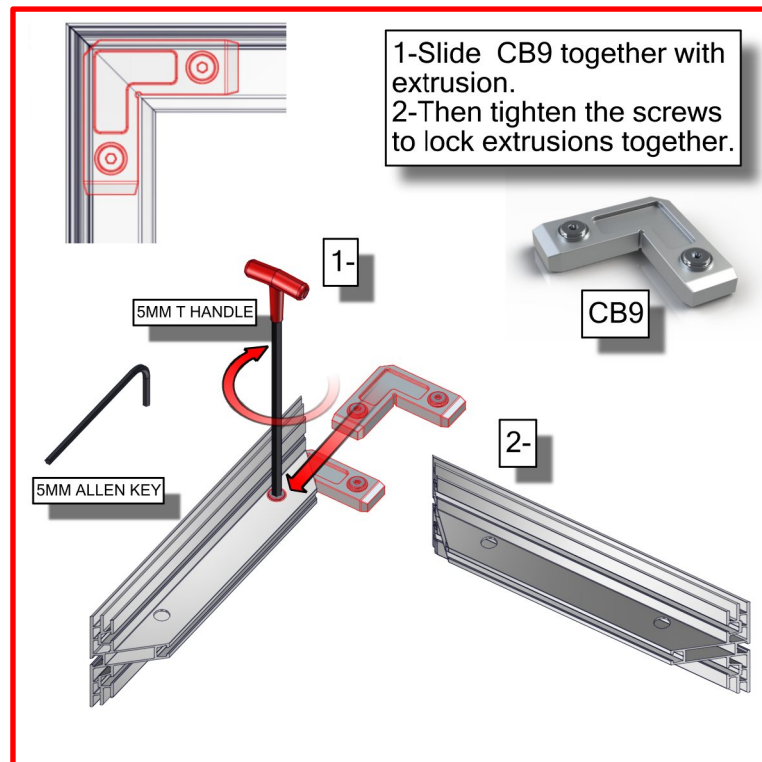
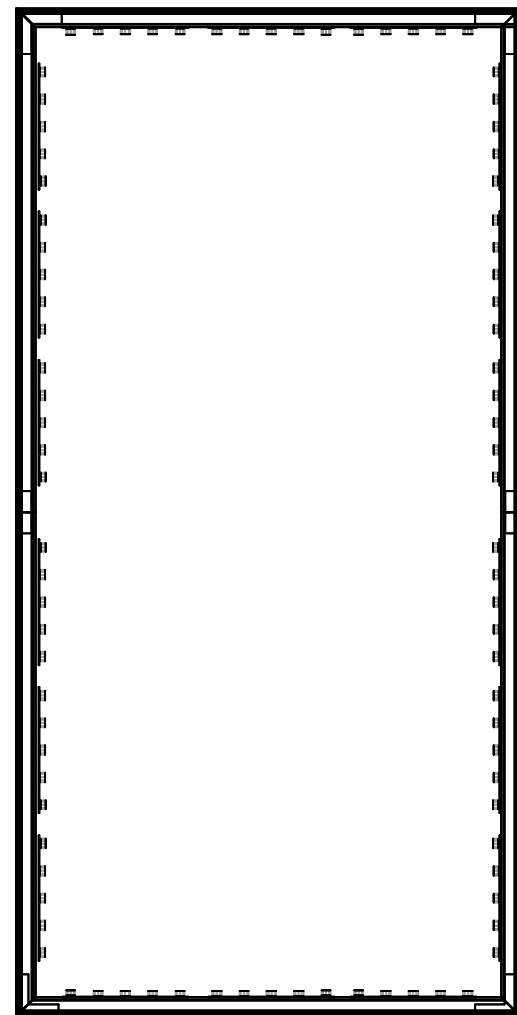

1. Redesign of this exhibit without approval by manufacturer may result in dangerous and unsafe structures. Manufacturer disclaims any responsibility for redesigned exhibits it does not approve in writing.

2. Parts and components such as panels and extrusions are manufactured to metric sizing. Where ever possible sizes have been noted in feet and inches as well as in metric. Below is the imperial to metric sizing table as reference. "Nominal" refers to approximate size.

2400mm = (94 1/2")	Phone Line / Fax
2100mm = (82 5/8")	Internet connection
1800mm = (70 7/8")	Outlet
1500mm = (59")	Main Drop (point of distrution)
1200mm = (47 1/4")	
900mm = (35 1/2")	
600mm = (23 5/8")	
300mm = (11 7/8")	

--- Wire running under carpet

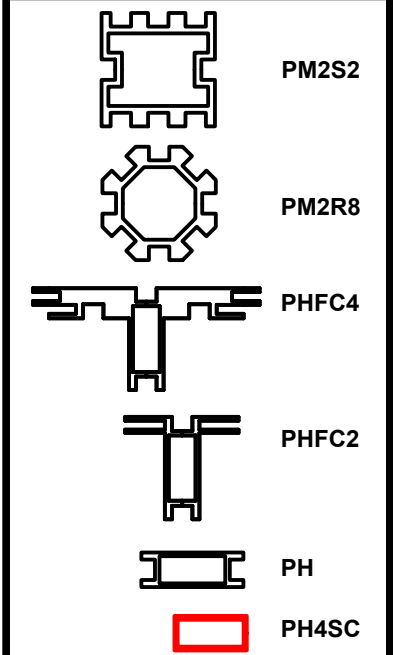

HYBRID PRO RENTAL KIT

Title: SET-UP INSTRUCTIONS

Code	#	Description
SW-FOOT	2	SMARTWALL SUPPORT FOOT
GRAPHIC C	1	94.5"H X 47.25"W BACKLIT DYESUB GRAPHIC W/FCE-2 ON PERIMETER
UNPRINTED C	1	94.5"H X 46.75"W WHITE FABRIC W/FCE-2 ON PERIMETER

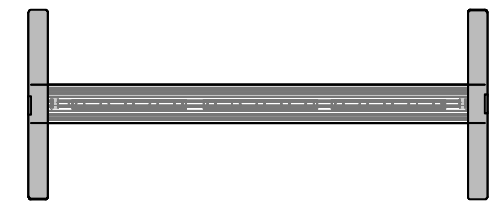

1. Redesign of this exhibit without approval by manufacturer may result in dangerous and unsafe structures. Manufacturer disclaims any responsibility for redesigned exhibits it does not approve in writing.

2. Parts and components such as panels and extrusions are manufactured to metric sizing. Where ever possible sizes have been noted in feet and inches as well as in metric. Below is the imperial to metric sizing table as reference. "Nominal" refers to approximate size.

2400mm = (94 1/2")	Phone Line / Fax
2100mm = (82 5/8")	Internet connection
1800mm = (70 7/8")	Outlet
1500mm = (59")	Main Drop (point of distrution)
1200mm = (47 1/4")	
900mm = (35 1/2")	
600mm = (23 5/8")	
300mm = (11 7/8")	

--- Wire running under carpet

FCE-2 TO PHFC4

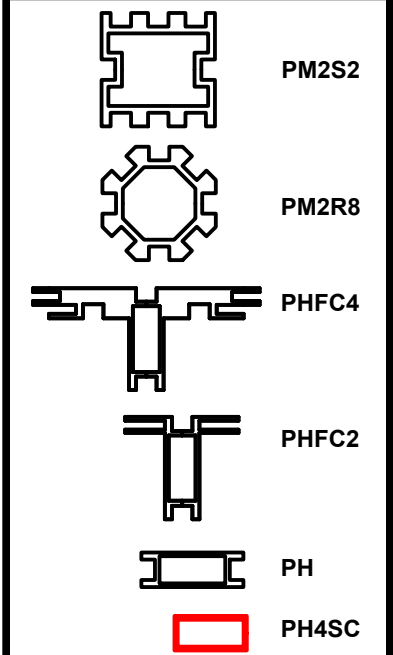
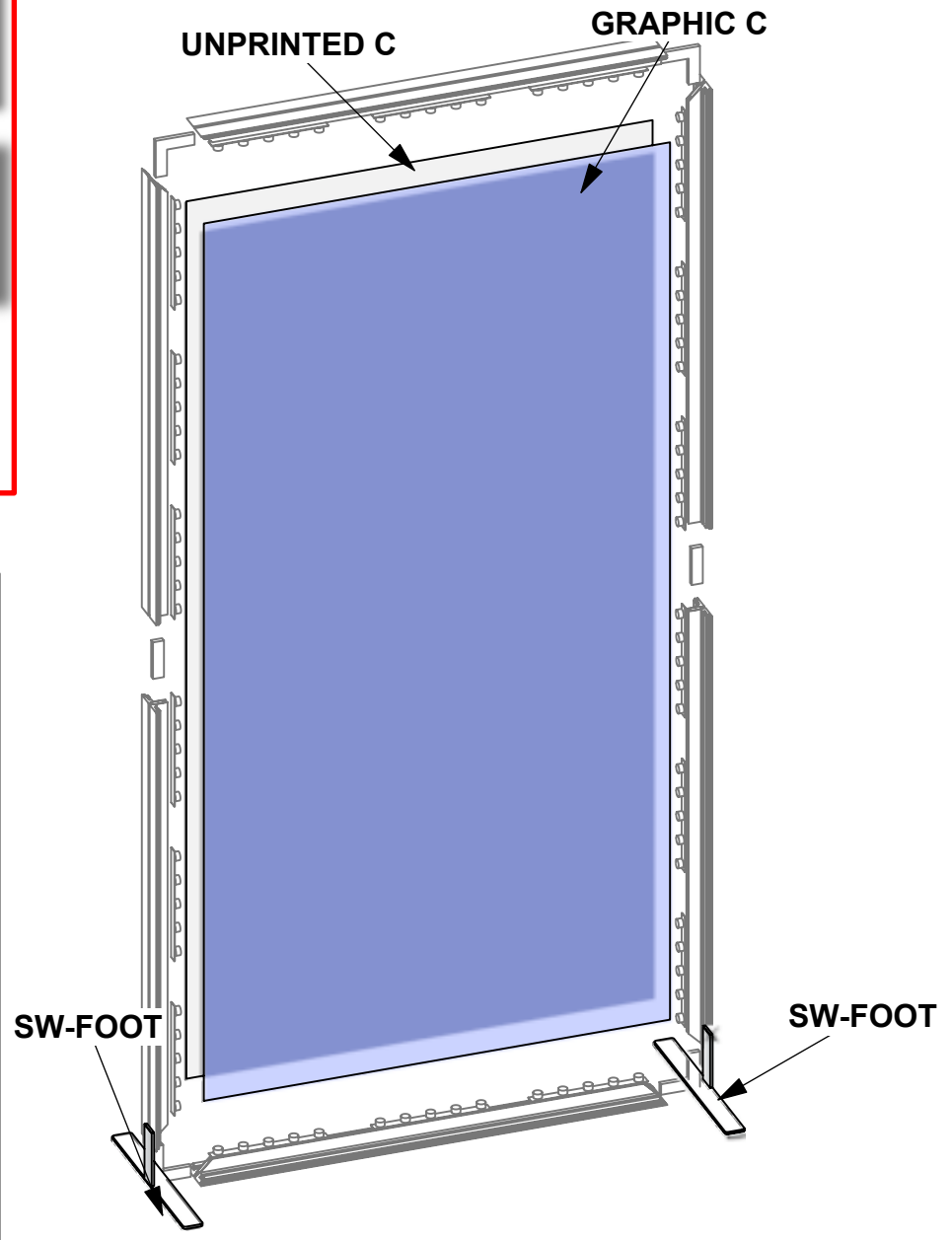
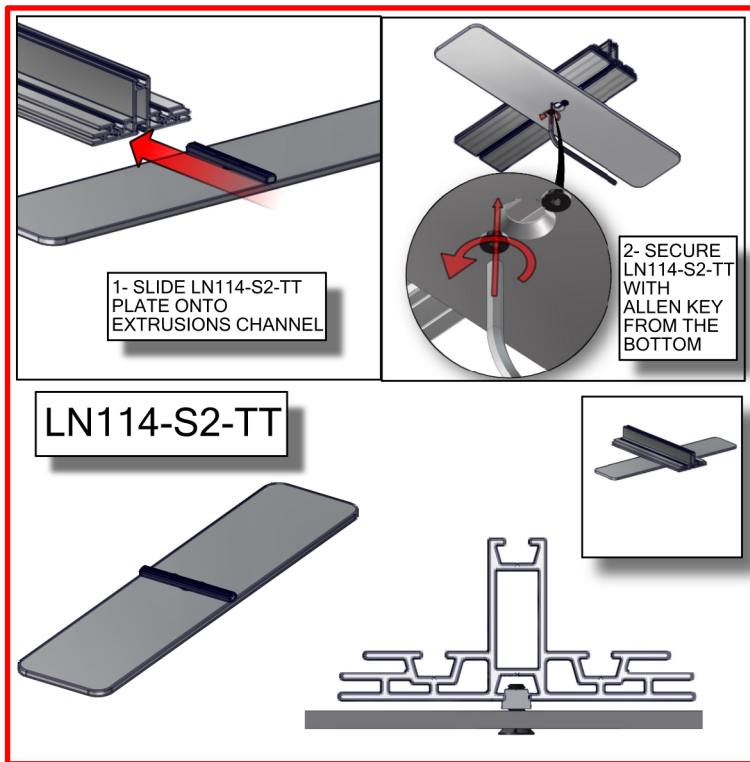
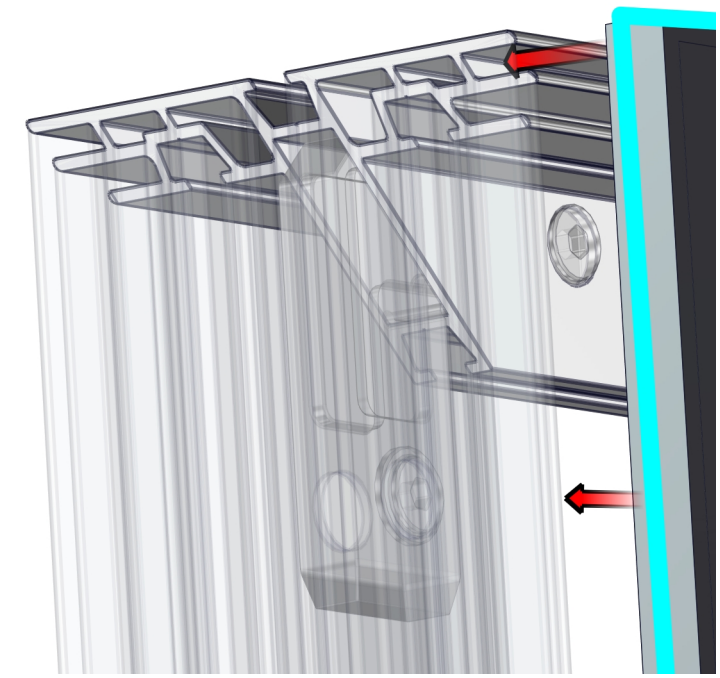

HYBRID PRO RENTAL KIT

Title: SET-UP INSTRUCTIONS

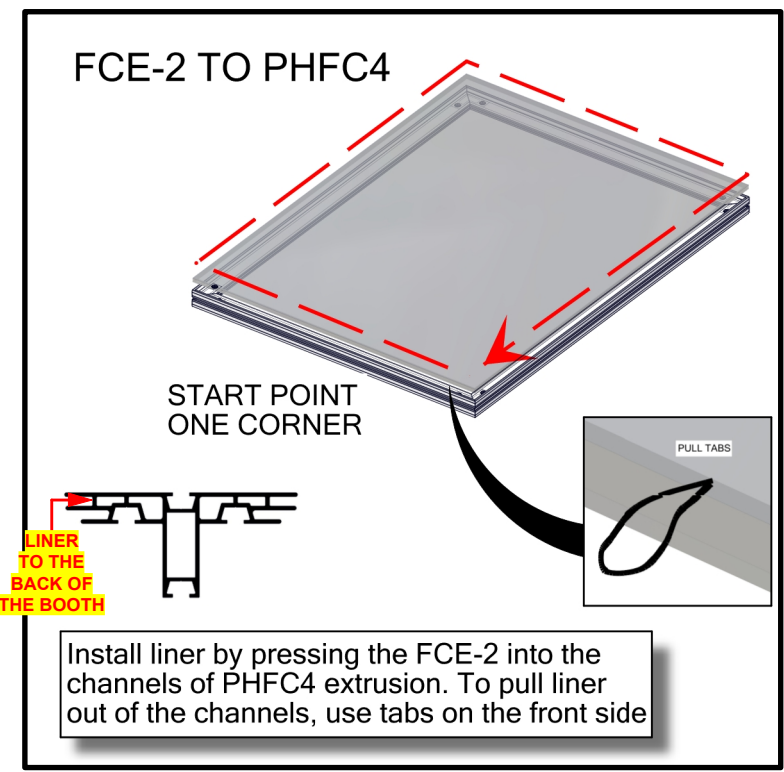
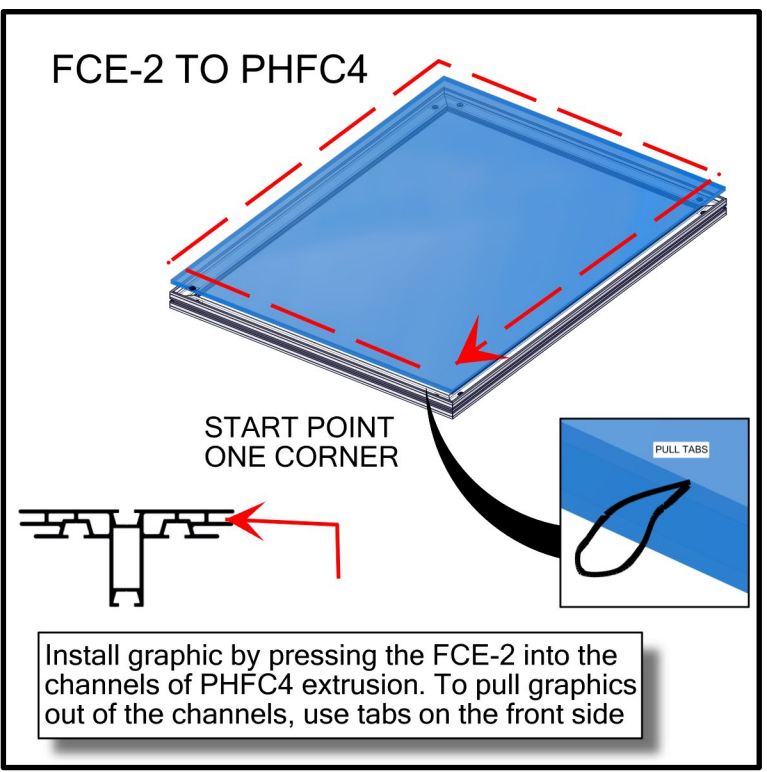

Code	#	Description
R55	2	510MM (20.08") PHFC2 EXTRUSION WITH LOCKS 2 ENDS
IB2	2	INLINE BRACKET CONNECTOR
CB9-S	4	50MM SQUARE PHCF2 CORNER BRACKET
R43	4	855MM (33.66") PHFC2 EXTRUSION WITH LOCKS 2 ENDS WITH SIDE CAM LOCKS

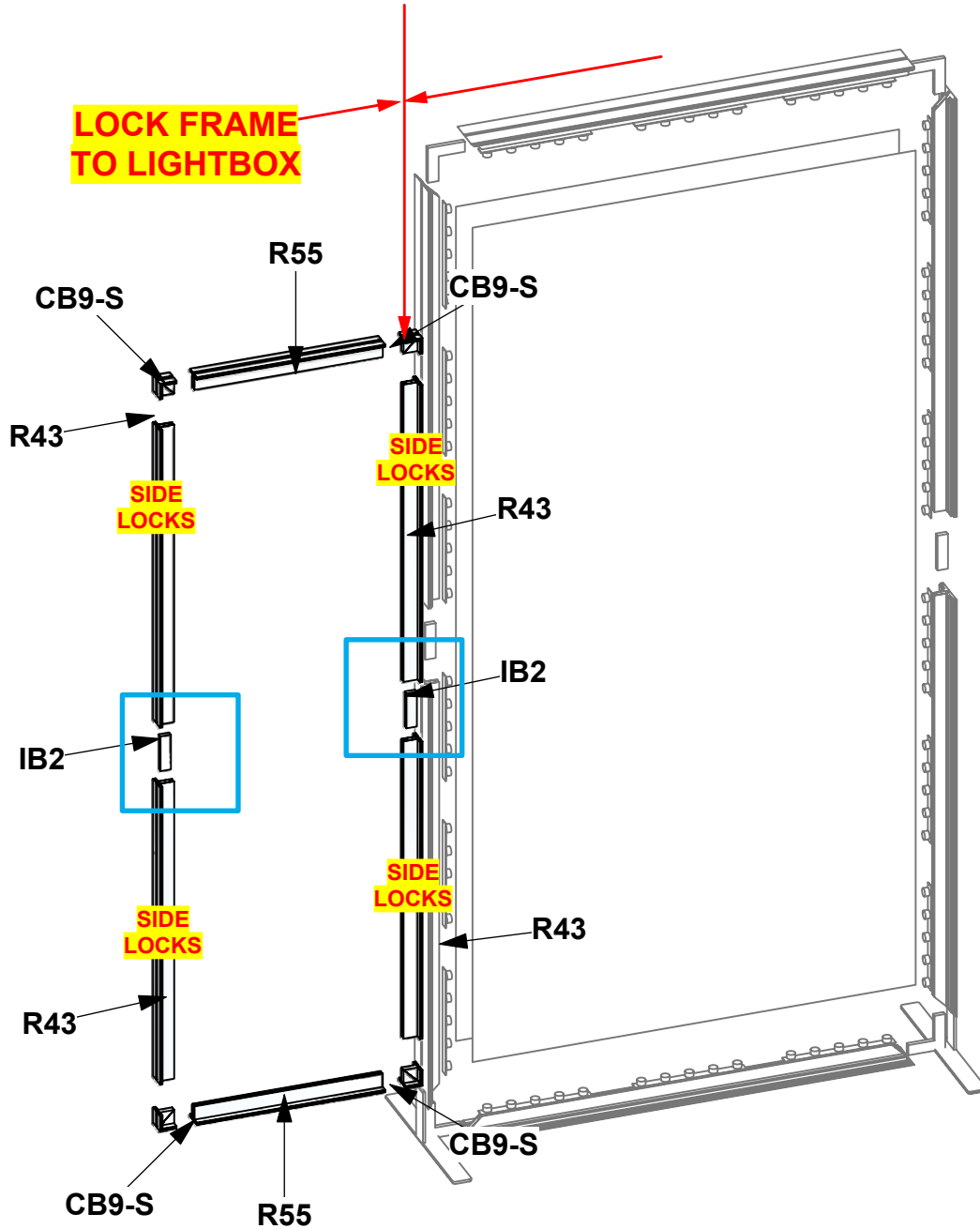
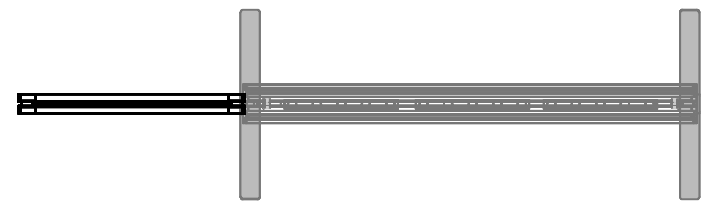
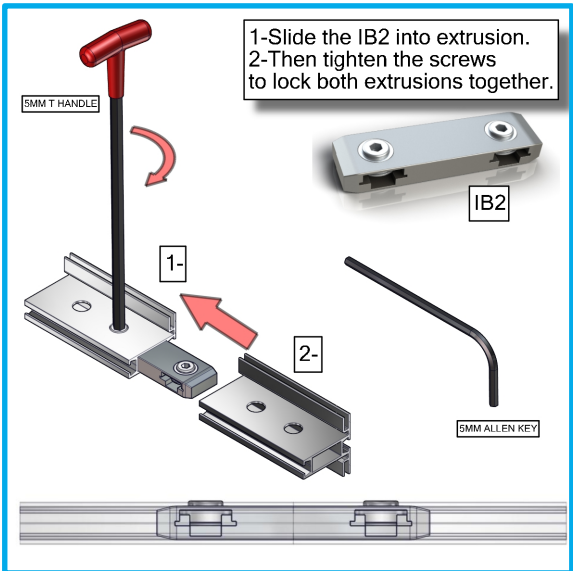
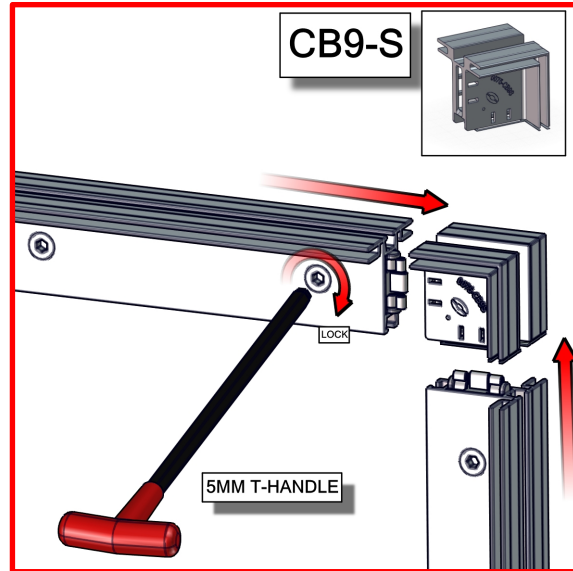

1. Redesign of this exhibit without approval by manufacturer may result in dangerous and unsafe structures. Manufacturer disclaims any responsibility for redesigned exhibits it does not approve in writing.

2. Parts and components such as panels and extrusions are manufactured to metric sizing. Where ever possible sizes have been noted in feet and inches as well as in metric. Below is the imperial to metric sizing table as reference. "Nominal" refers to approximate size.

2400mm = (94 1/2")	Phone Line / Fax
2100mm = (82 5/8")	Internet connection
1800mm = (70 7/8")	Outlet
1500mm = (59")	Main Drop (point of distrution)
1200mm = (47 1/4")	
900mm = (35 1/2")	
600mm = (23 5/8")	
300mm = (11 7/8")	

--- Wire running under carpet

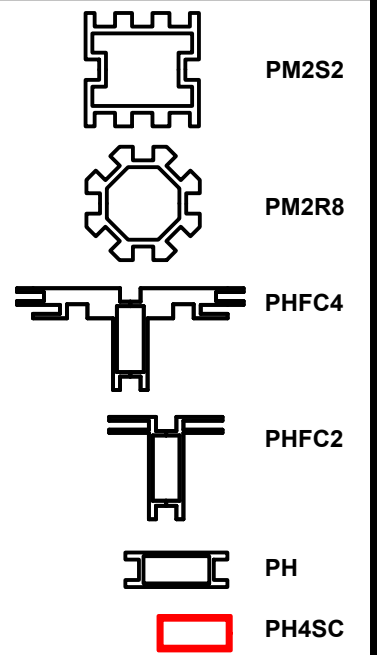

HYBRID PRO RENTAL KIT

Title: SET-UP INSTRUCTIONS

Code	#	Description
SW-FOOT	2	SMARTWALL SUPPORT FOOT
R10	2	1200MM (47.24") PHFC4 EXTRUSION WITH MITRE CUT 1 END FOR CB9 ONE END-IB2 HOLES ONE END
R41	2	900MM (35.43") PHFC4 EXTRUSION WITH MITRE CUT 1 END FOR CB9 ONE END-IB2 HOLES ONE END
CB9	4	CB9 CORNER BRACKET
R26	2	900MM (35.43") PHFC4 EXTRUSION WITH MITRE CUT BOTH ENDS
IB2	2	INLINE BRACKET CONNECTOR
R42	2	810MM (31.89") 50MM50MM PM2S 4 WAY ROUND EXTRUSION

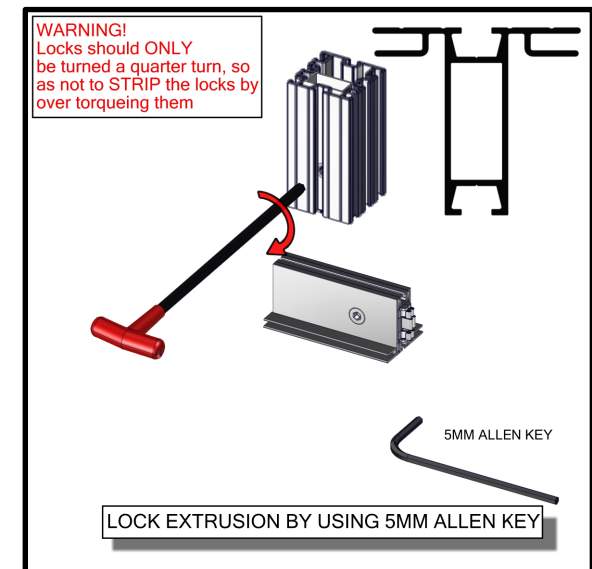
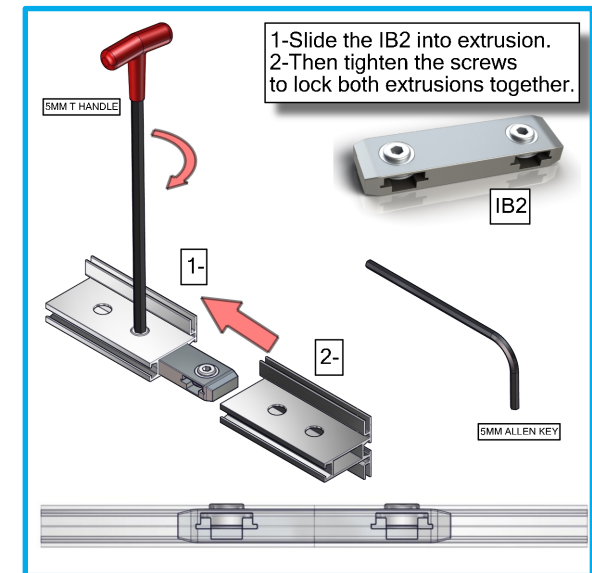
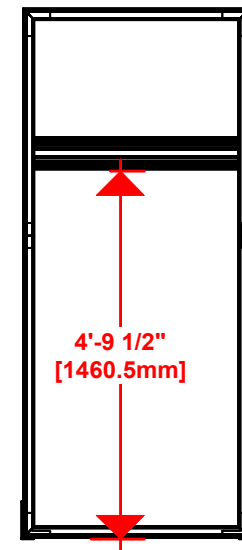
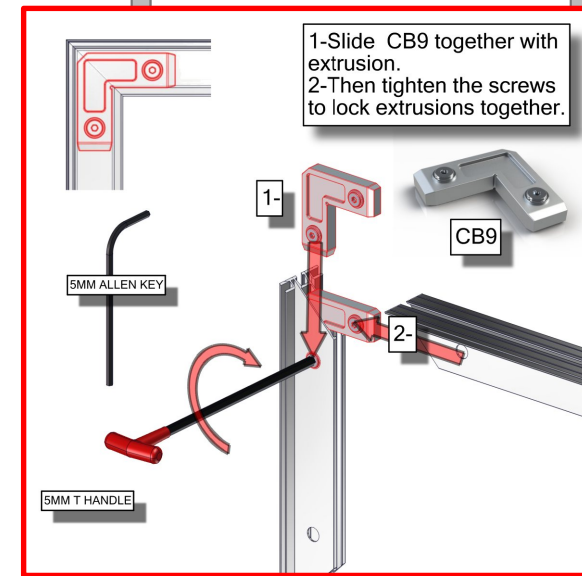
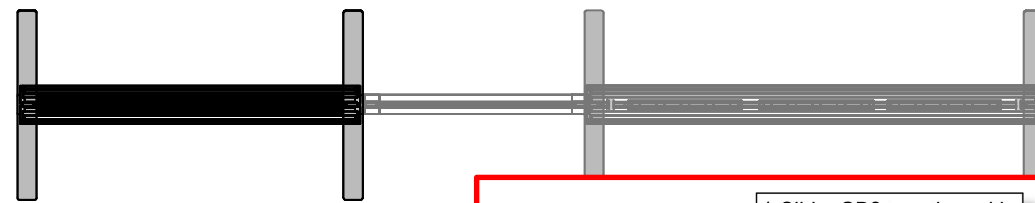
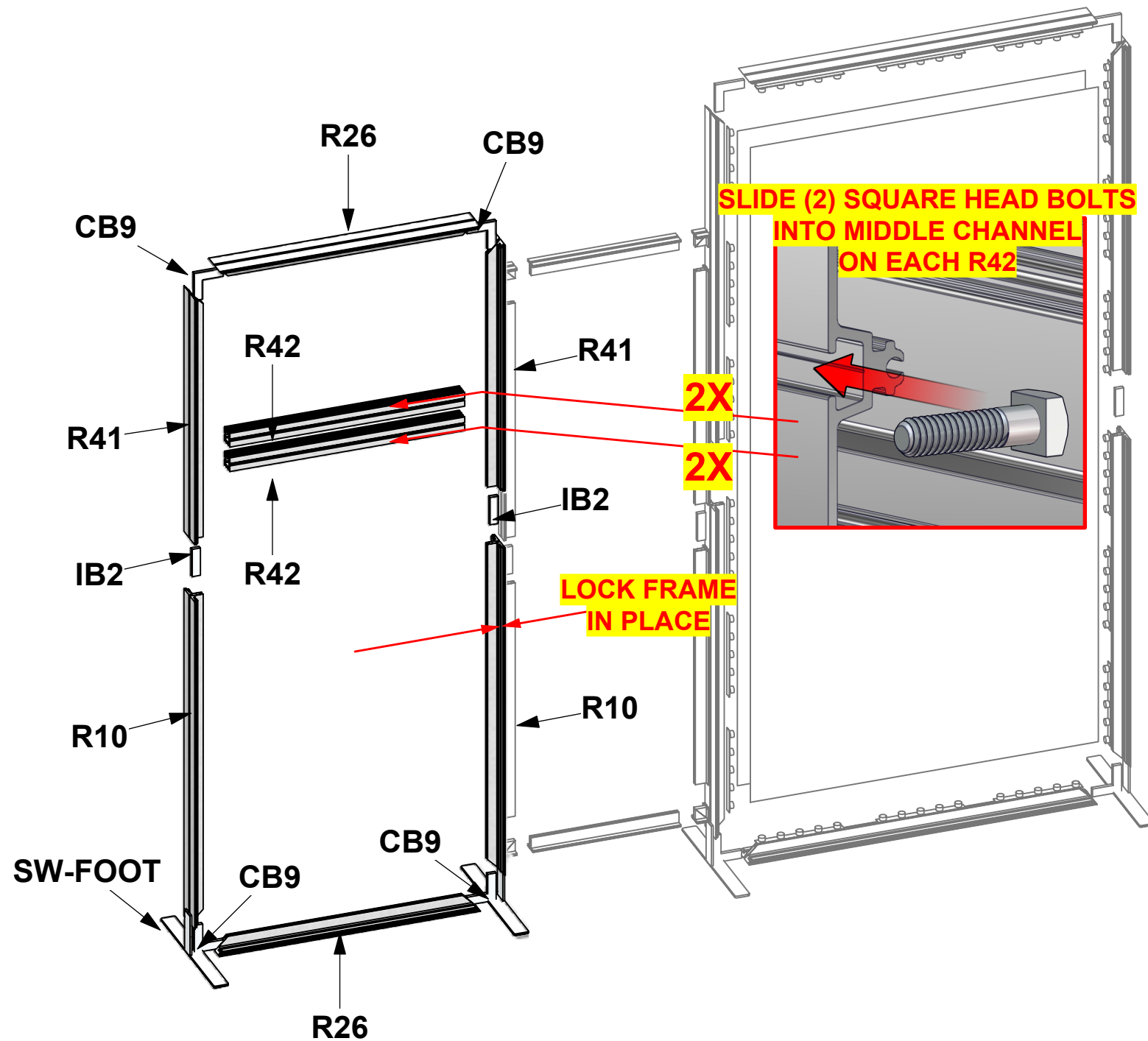

1. Redesign of this exhibit without approval by manufacturer may result in dangerous and unsafe structures. Manufacturer disclaims any responsibility for redesigned exhibits it does not approve in writing.

2. Parts and components such as panels and extrusions are manufactured to metric sizing. Where ever possible sizes have been noted in feet and inches as well as in metric. Below is the imperial to metric sizing table as reference. "Nominal" refers to approximate size.

2400mm = (94 1/2")	Phone Line / Fax
2100mm = (82 5/8")	Internet connection
1800mm = (70 7/8")	Outlet
1500mm = (59")	Main Drop (point of distrution)
1200mm = (47 1/4")	
900mm = (35 1/2")	
600mm = (23 5/8")	
300mm = (11 7/8")	

Wire running under carpet

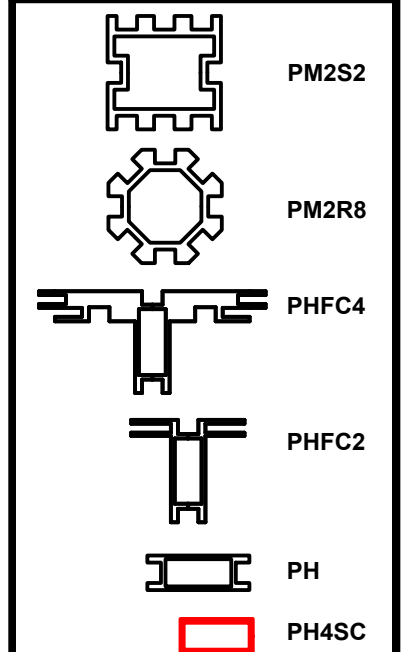

HYBRID PRO RENTAL KIT

Title: SET-UP INSTRUCTIONS

Code	#	Description
GRAPHIC A	1	82.67"H X 35.43"W SINGLE SIDED DYESUB GRAPHIC W/FCE-2 ON PERIMETER
MM-MB	1	MEDIUM MONITOR BRACKET FOR MONITORS 15"-40"
GRAPHIC B	1	70.86"H X 23.62"W SINGLE SIDED DYESUB GRAPHIC W/FCE-2 ON PERIMETER

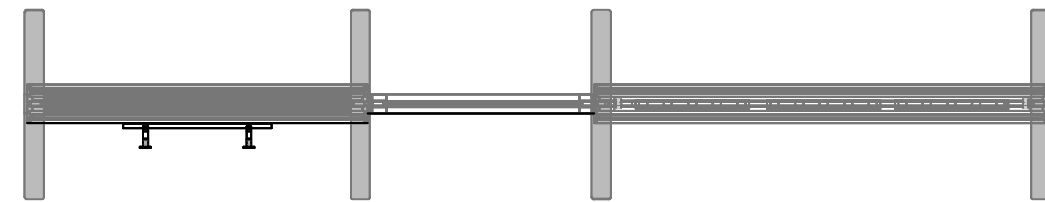

1. Redesign of this exhibit without approval by manufacturer may result in dangerous and unsafe structures. Manufacturer disclaims any responsibility for redesigned exhibits it does not approve in writing.

2. Parts and components such as panels and extrusions are manufactured to metric sizing. Where ever possible sizes have been noted in feet and inches as well as in metric. Below is the imperial to metric sizing table as reference. *Nominal" refers to approximate size.

2400mm = (94 1/2")	Phone Line / Fax
2100mm = (82 5/8")	Internet connection
1800mm = (70 7/8")	Outlet
1500mm = (59")	Main Drop (point of distrution)
1200mm = (47 1/4")	
900mm = (35 1/2")	
600mm = (23 5/8")	
300mm = (11 7/8")	

--- Wire running under carpet

FCE-2 TO PHFC4

START POINT ONE CORNER

PULL TABS

Install graphic by pressing the FCE-2 into the channels of PHFC4 extrusion. To pull graphics out of the channels, use tabs on the front side

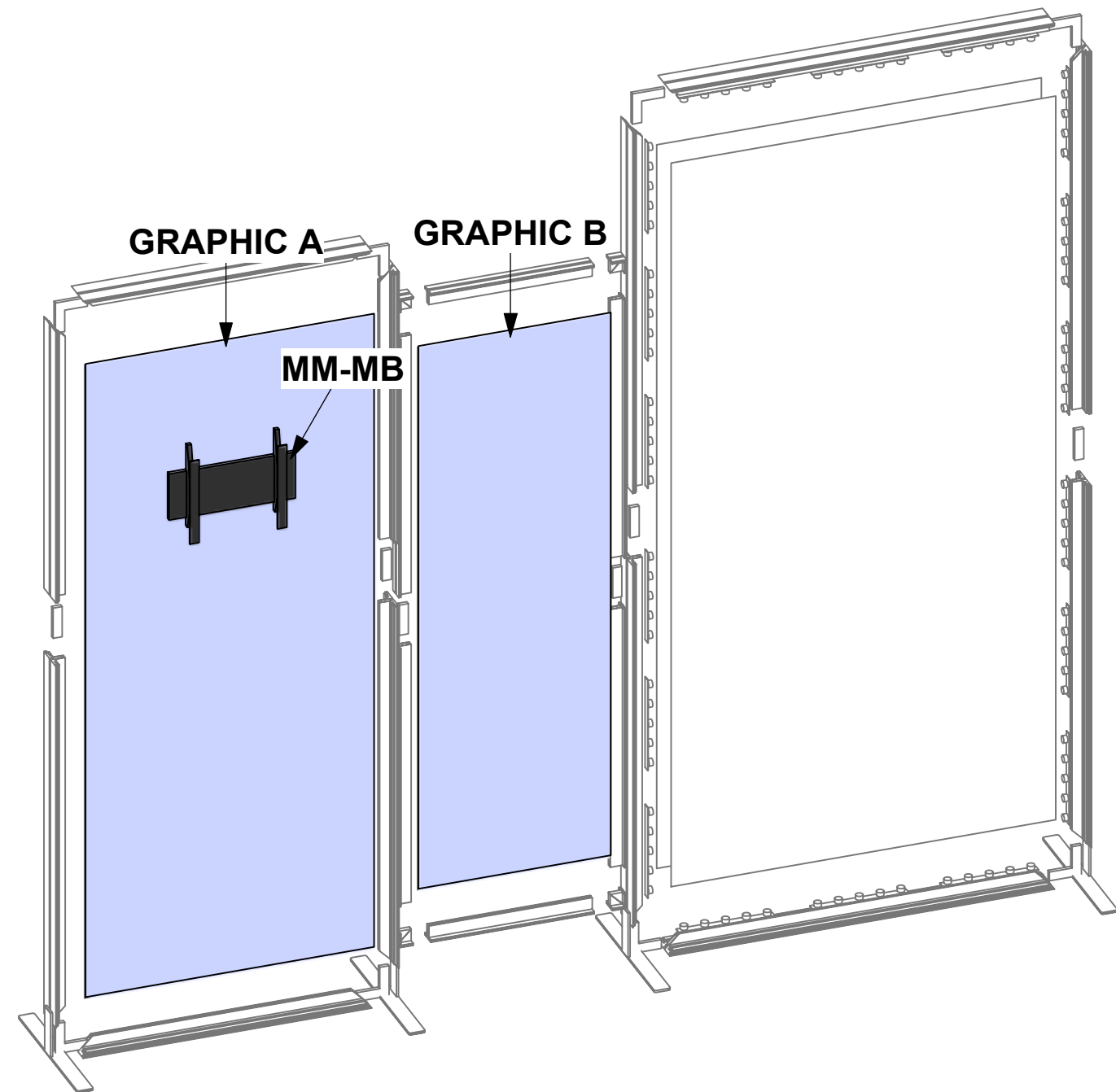

- PM2S2
- PM2R8
- PHFC4
- PHFC2
- PH
- PH4SC

MM-MB

BOLT-1

1/4 ZINC ALLOY FLANGE WING NUT

- 1- INSERT BOLTS INTO MIDDLE CHANNEL. THEN SECURE MONITOR MOUNT WITH WING NUTS.
- 2- ATTACH MONITOR TO BRACKETS SEE SANUS MANUAL FOR MORE INFO

HYBRID PRO RENTAL KIT

Title: SET-UP INSTRUCTIONS

SET UP INSTRUCTIONS:

1. CONNECT BOTTOM AND TOP RAILS FOLLOWING THE LABELS
2. CONNECT SIDE RAILS
3. CLEAN THE FRAME AND PLACE THEM ON CLEAN PLACE
4. CAREFULLY REMOVE FABRIC COVER FROM BAGS
5. PLACE COVER AROUND THE BOTTOM OF THE FRAME
6. PULL COVER CAREFULLY UP TO THE TOP
7. CLOSE ALL ZIPPERS
8. ADJUST FABRIC AROUND THE FRAME

BREAK DOWN INSTRUCTIONS:

REVERSE SET-UP STEPS TO BREAKDOWN FRAME

FABRIC CARE INSTRUCTIONS:

1. UNZIP COVER ZIPPERS
2. CAREFULLY REMOVE FABRIC COVER
3. CLOSE ALL ZIPPERS
4. FOLD OR ROLL NEATLY
5. PLACE FABRIC IN COVER BAG

PART LIST:

- PER UNIT
- 14 30MM DIA. TUBE SECTIONS
 - 1 FABRIC COVER

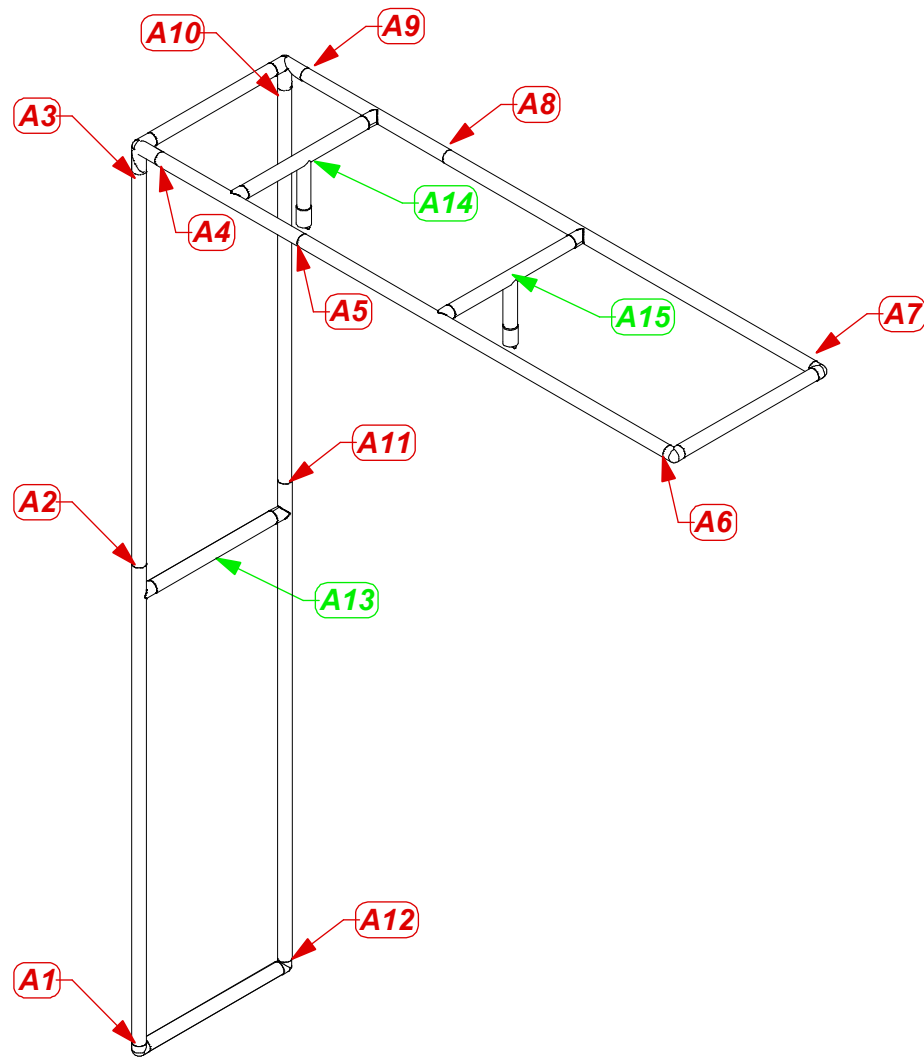

Frame 'A' Assembly

Assemble frame as shown

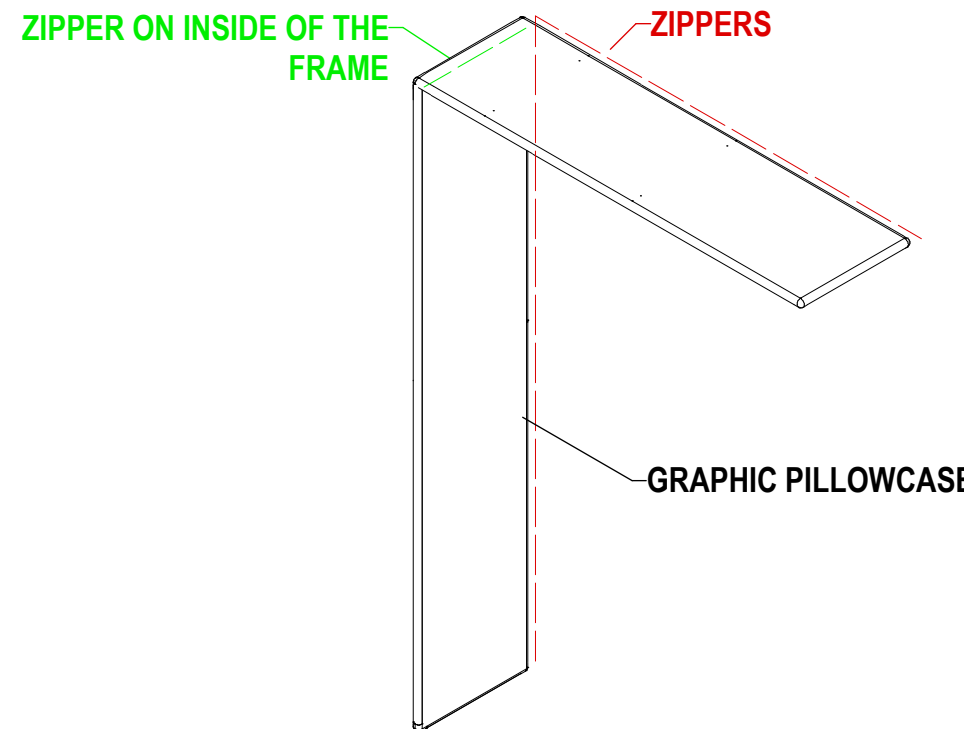
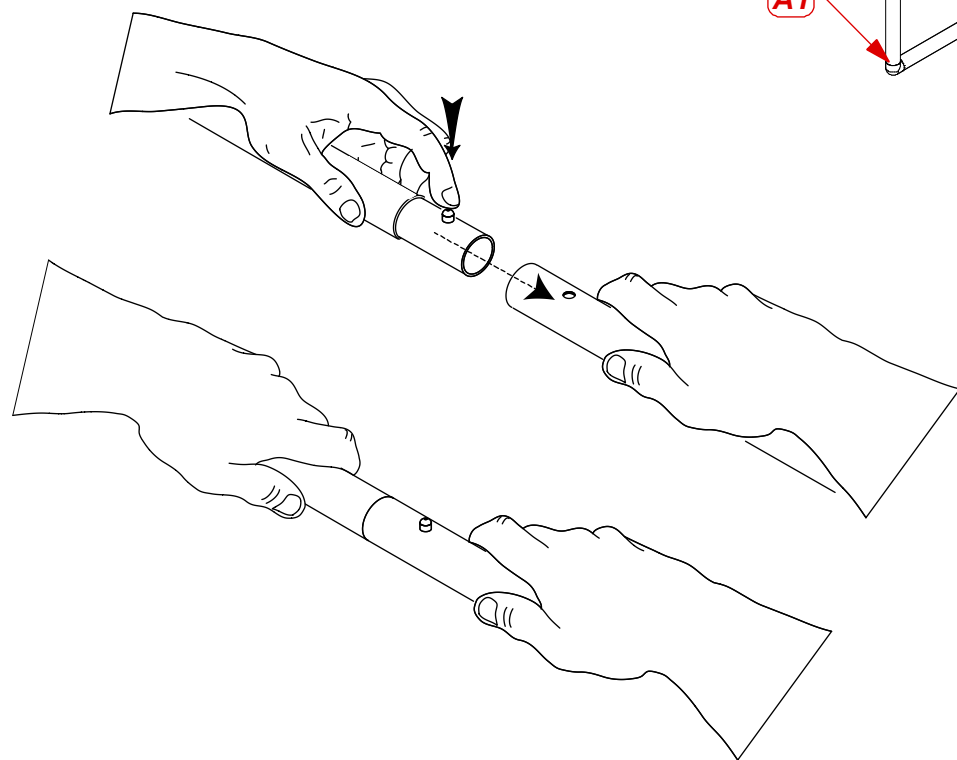
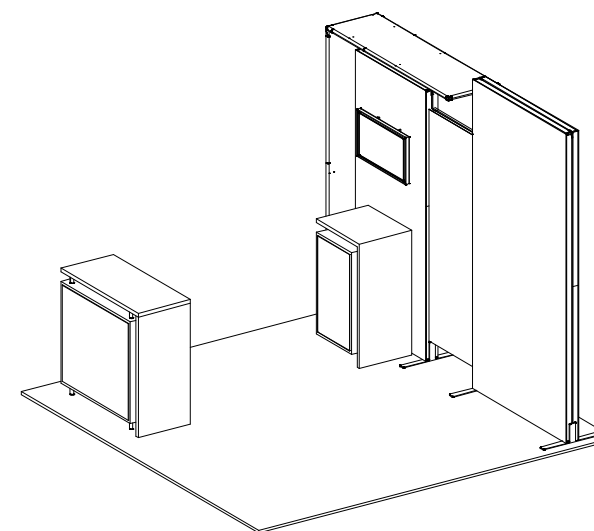

1. Redesign of this exhibit without approval by manufacturer may result in dangerous and unsafe structures. Manufacturer disclaims any responsibility for redesigned exhibits it does not approve in writing.

2. Parts and components such as panels and extrusions are manufactured to metric sizing. Where ever possible sizes have been noted in feet and inches as well as in metric. Below is the imperial to metric sizing table as reference. "Nominal" refers to approximate size.

2400mm = (94 1/2")	Phone Line / Fax
2100mm = (82 5/8")	Internet connection
1800mm = (70 7/8")	Outlet
1500mm = (59")	Main Drop (point of distrution)
1200mm = (47 1/4")	
900mm = (35 1/2")	
600mm = (23 5/8")	
300mm = (11 7/8")	

--- Wire running under carpet

	PM2S2
	PM2R8
	PHFC4
	PHFC2
	PH
	PH4SC

HYBRID PRO RENTAL KIT

Title: SET-UP INSTRUCTIONS

Code	#	Description
CUST FS	1	APPROX. 62" W X 90" H X 18" D CUSTOM L-SHAPED FABRIC STRUCTURE



1. Redesign of this exhibit without approval by manufacturer may result in dangerous and unsafe structures. Manufacturer disclaims any responsibility for redesigned exhibits it does not approve in writing.

2. Parts and components such as panels and extrusions are manufactured to metric sizing. Where ever possible sizes have been noted in feet and inches as well as in metric. Below is the imperial to metric sizing table as reference. "Nominal" refers to approximate size.

2400mm = (94 1/2")	Phone Line / Fax
2100mm = (82 5/8")	Internet connection
1800mm = (70 7/8")	Outlet
1500mm = (59")	Main Drop (point of distrution)
1200mm = (47 1/4")	
900mm = (35 1/2")	
600mm = (23 5/8")	
300mm = (11 7/8")	

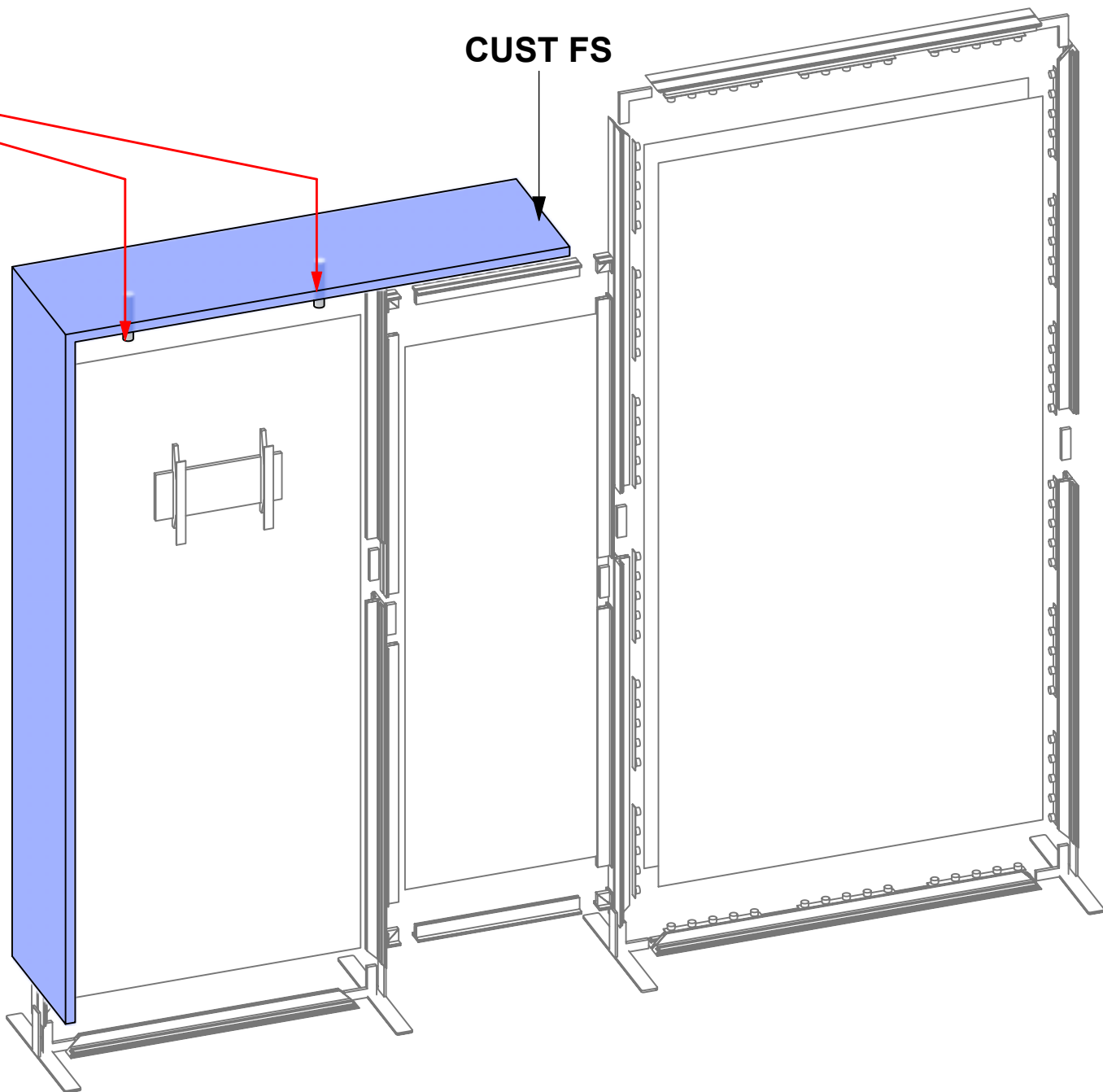
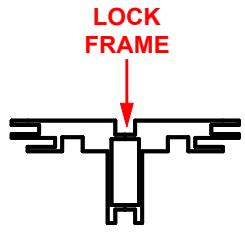
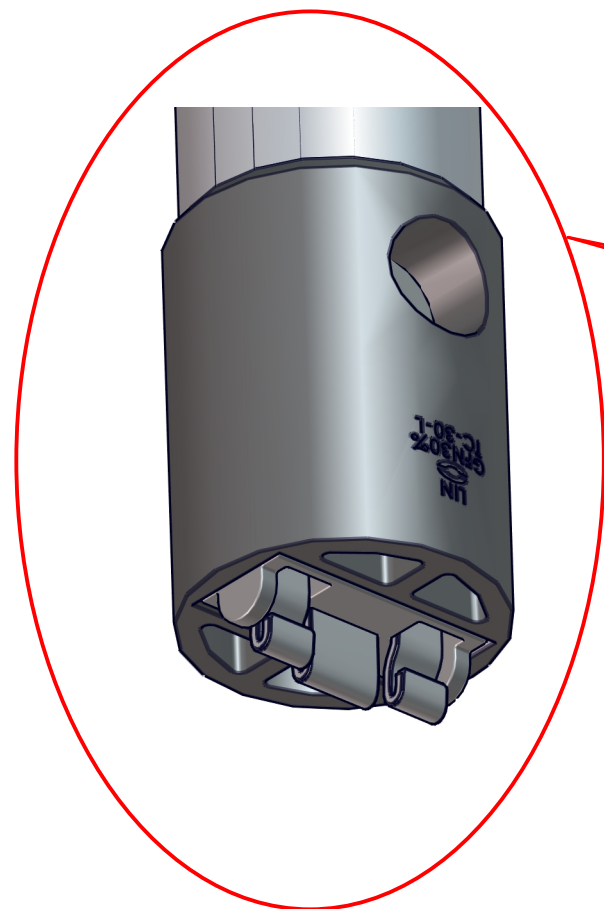
--- Wire running under carpet

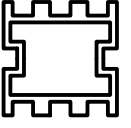
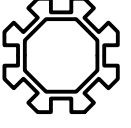
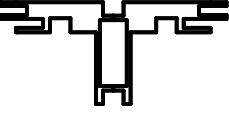
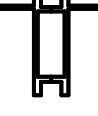

-  PM2S2
-  PM2R8
-  PHFC4
-  PHFC2
-  PH
-  PH4SC

HYBRID PRO RENTAL KIT

Title: SET-UP INSTRUCTIONS

PACKING INSTRUCTIONS



(1) STEAMER, (2) HARDWARE BOX



(4) R43, (2) R55, (2) R42,
(2) R23, (2) R41M (4) SW FOOT



(4) R10, (2) R42, (1) A11

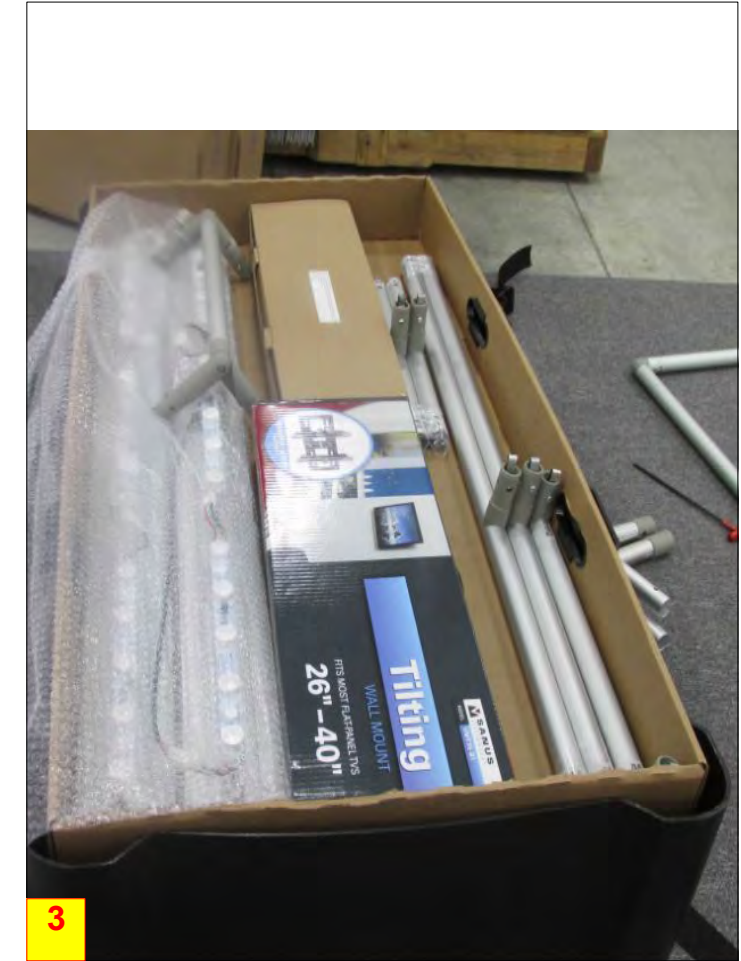

(2) R9, (1) MM-MB,
(1) FABRIC STRUCTURE

CASE # 1

LEGEND		GREY FOAM FOLDED TO FILL EMPTY SPACES OR USED AS PROTECTION
		1/8" CARDBOARD SPACER (PUT IN BETWEEN EVERY PANEL)
		DIVIDER
		1/4" WHITE FOAM (USED AS PROTECTION DOOR PANELS W/ LOCKS)



R-HPC-01-B

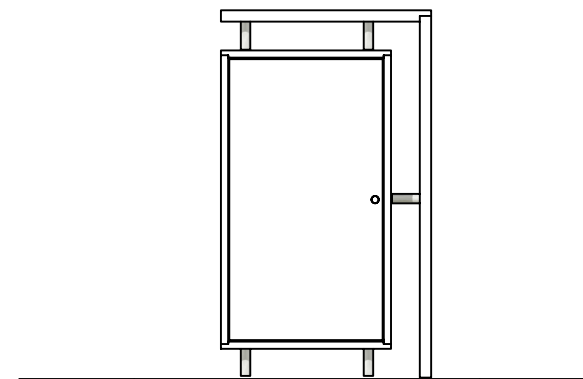
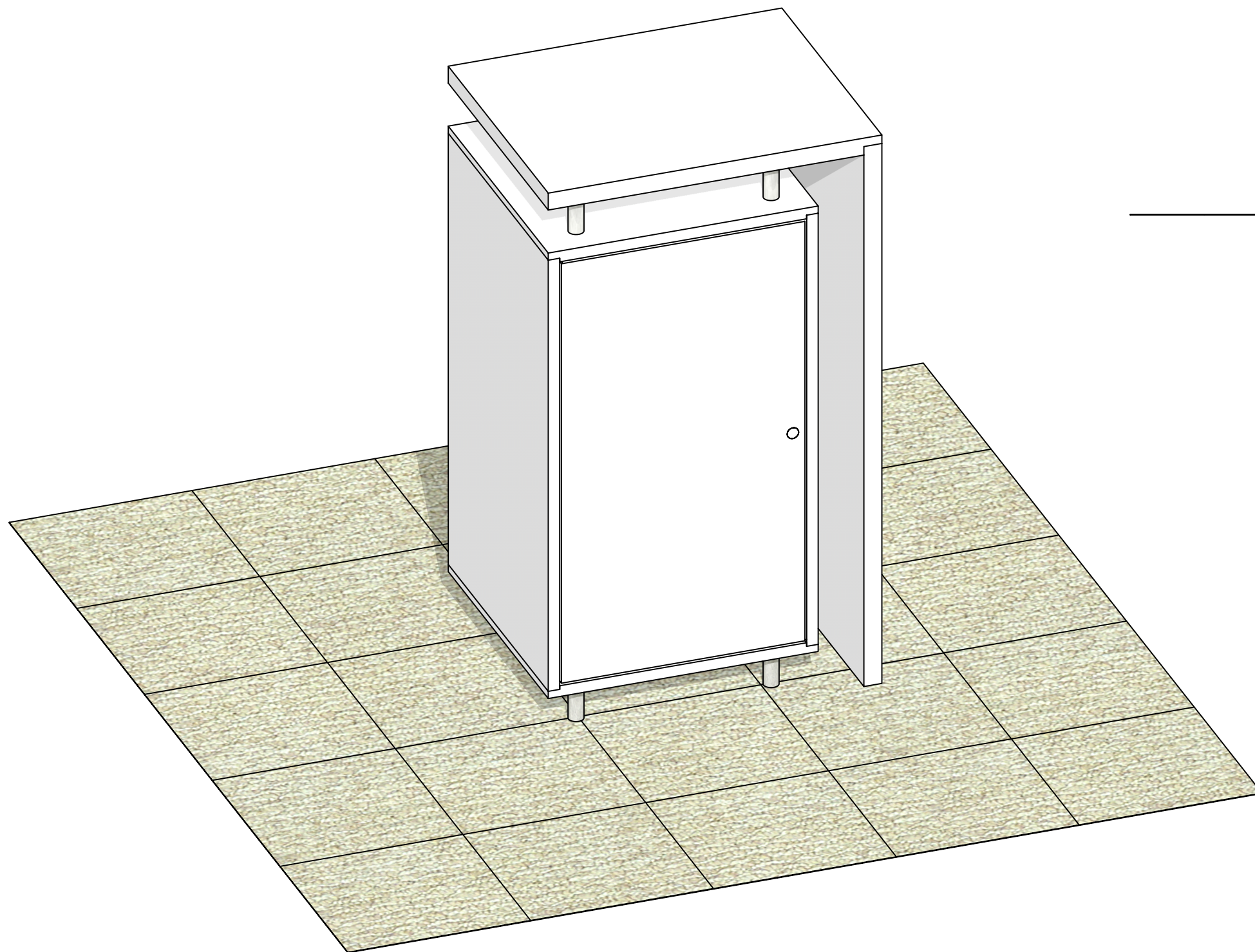

Code	#	Description
R-HPC-01-B-CT	1	4' X 2' X 2' L-SHAPED COUNTER TOP FOR R-HPC-01-A UNIT
SS4	4	SILVER SS4 SHELF SUPPORTS
SO-1 1/4 X 3	9	1 1/4" X 3" L STANDOFF ASSEMBLY
R-HPC-01-B-CAB	1	4' X 2" X 2' CUSTOM CABINET WITH SINGLE DOOR ON BACK (HIDDEN HINGES), INTERNAL SHELF AND WIRE M
R-HPC-01-A-INT	1	2' X 2' X 5/8" INTERNAL SHELF FOR HPC-01-B

BOM

R-HPC-01-B

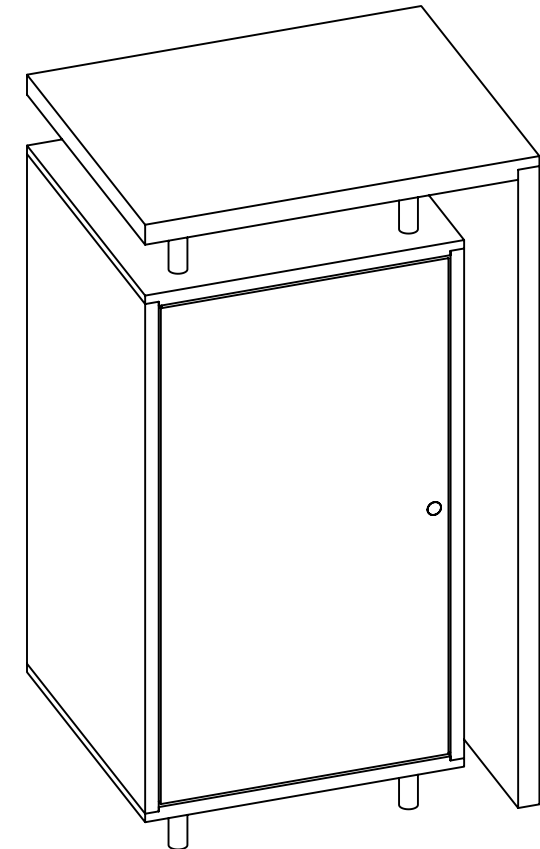
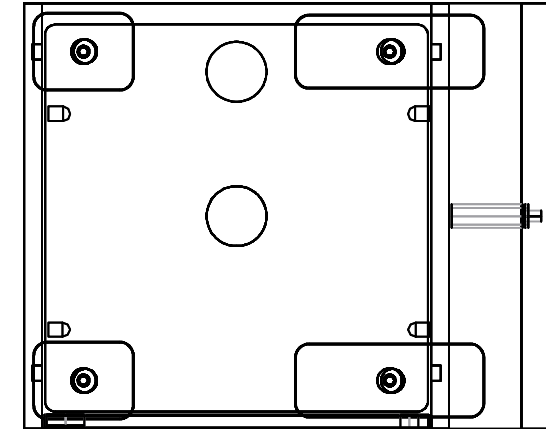
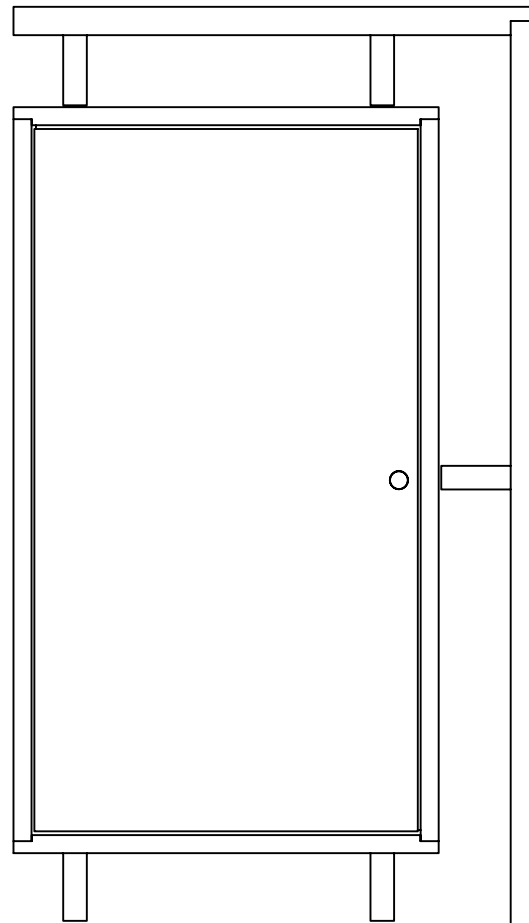
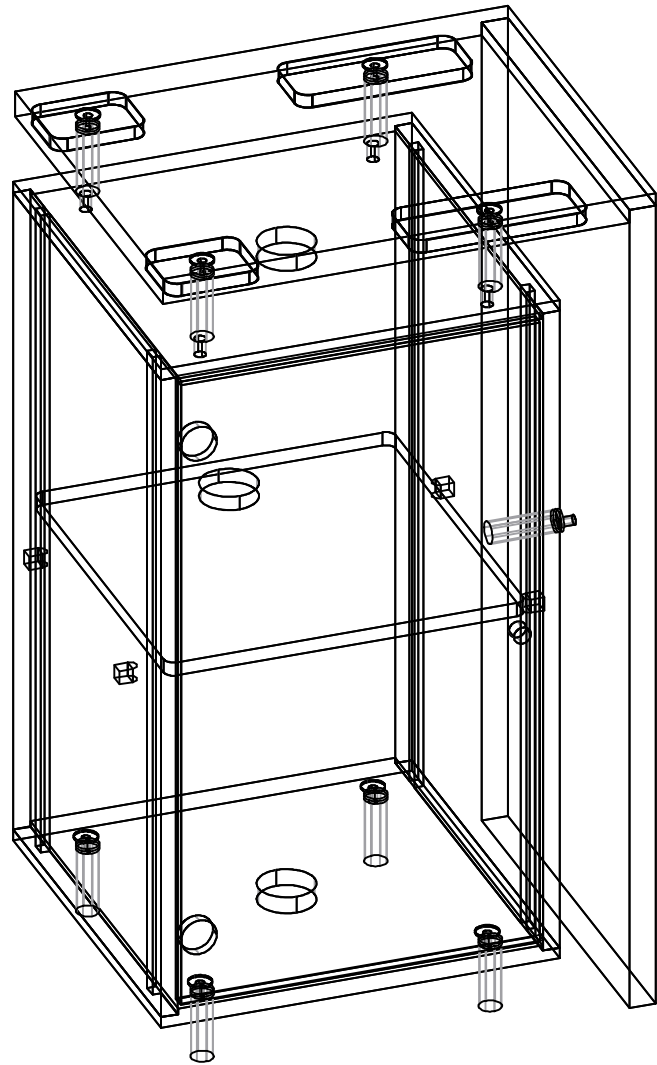

1. Redesign of this exhibit without approval by manufacturer may result in dangerous and unsafe structures. Manufacturer disclaims any responsibility for redesigned exhibits it does not approve in writing.

2. Parts and components such as panels and extrusions are manufactured to metric sizing. Where ever possible sizes have been noted in feet and inches as well as in metric. Below is the imperial to metric sizing table as reference. "Nominal" refers to approximate size.

2400mm = (94 1/2")	☒ Phone Line / Fax
2100mm = (82 5/8")	☒ Internet connection
1800mm = (70 7/8")	☒ Outlet
1500mm = (59")	☒ Main Drop (point of distrution)
1200mm = (47 1/4")	
900mm = (35 1/2")	
600mm = (23 5/8")	
300mm = (11 7/8")	

--- Wire running under carpet

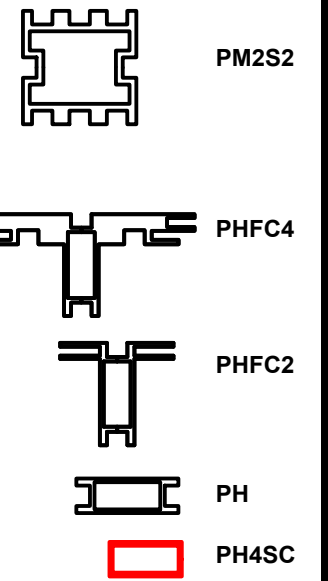
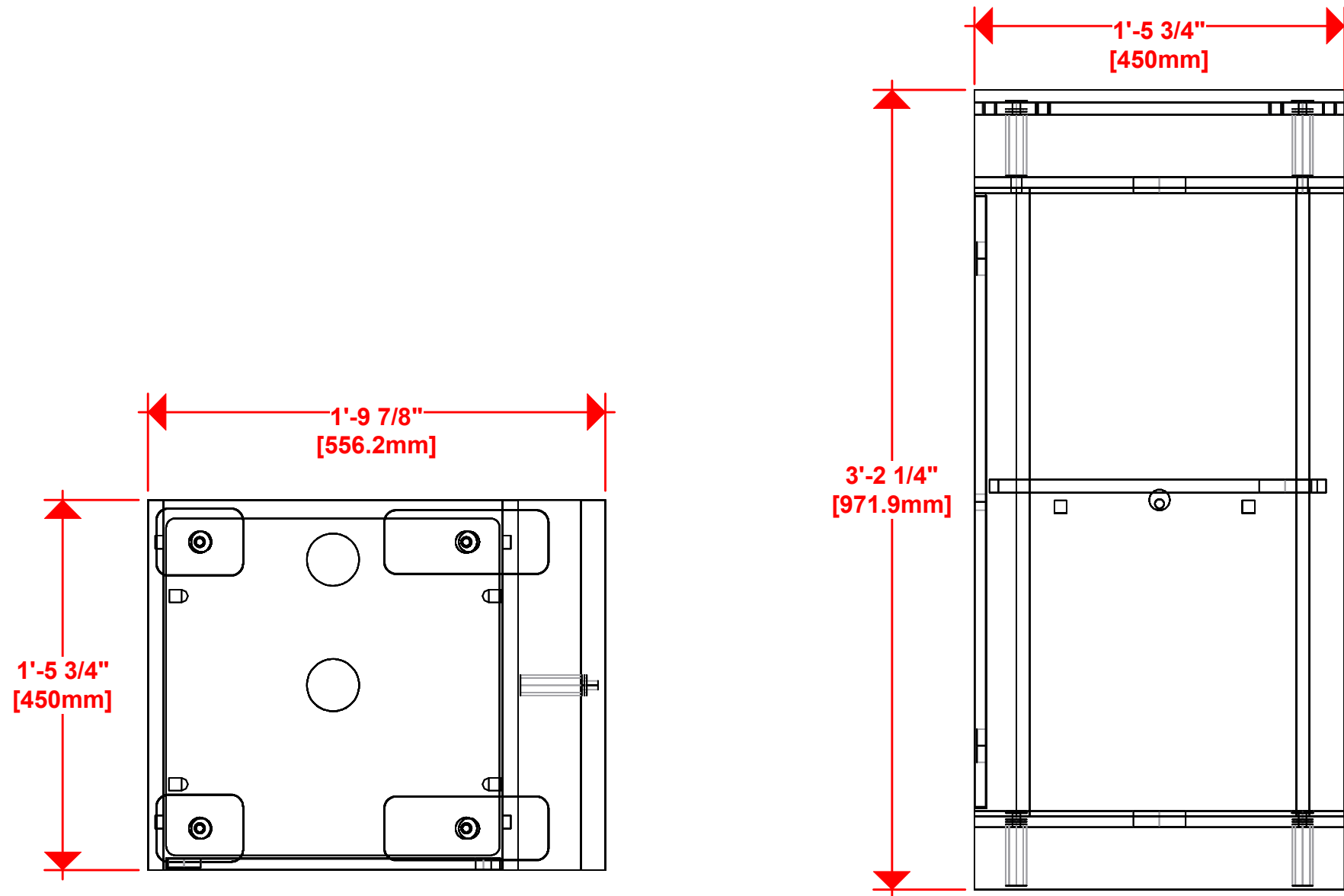

HYBRID PRO RENTAL KIT

Title: SET-UP INSTRUCTIONS

Code	#	Description
SO-1 1/4 X 3	9	1 1/4" X 3" L STANDOFF ASSEMBLY
R-HPC-01-B-C	1	4' X 2" X 2' CUSTOM CABINET WITH SINGLE DOOR ON BACK (HIDDEN HINGES), INTERNAL SHELF AND WIRE MANAGEMENT HOLES

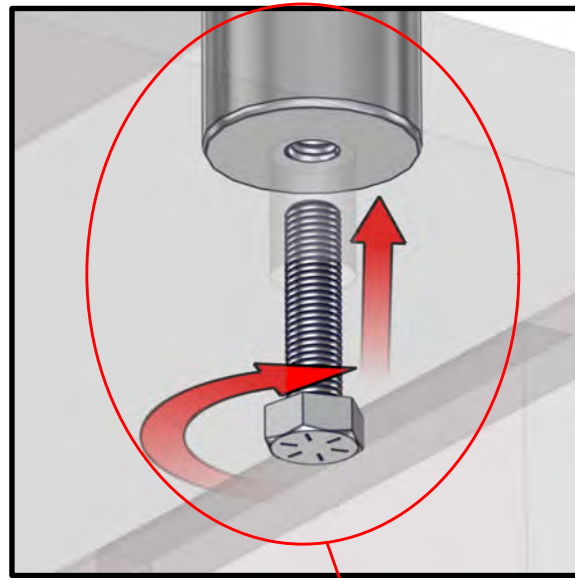

R-HPC-01-B-CAB

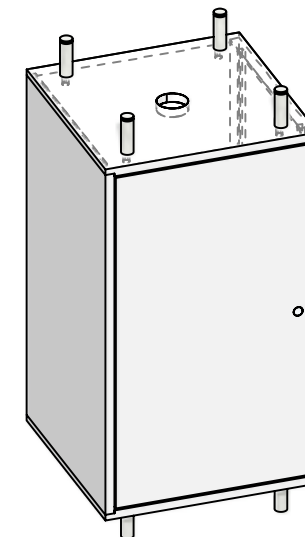
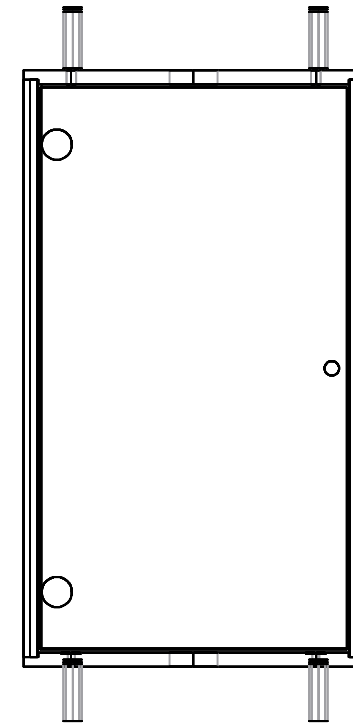
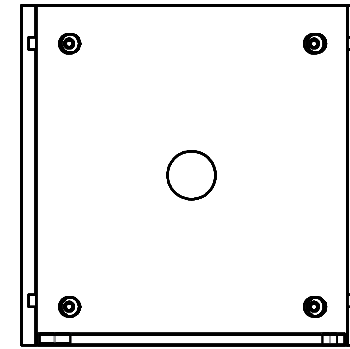
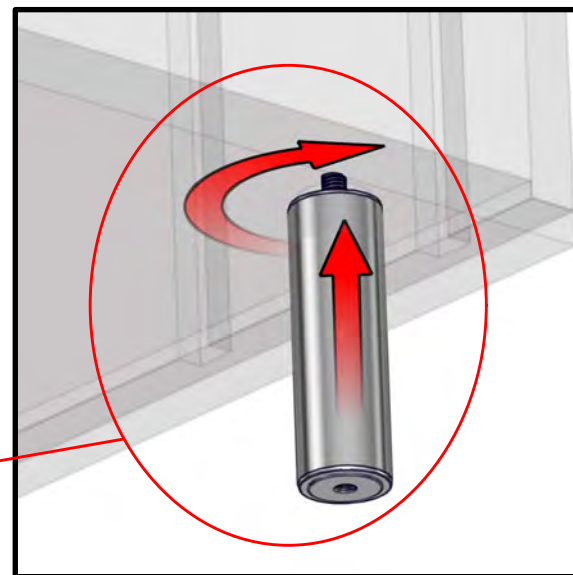
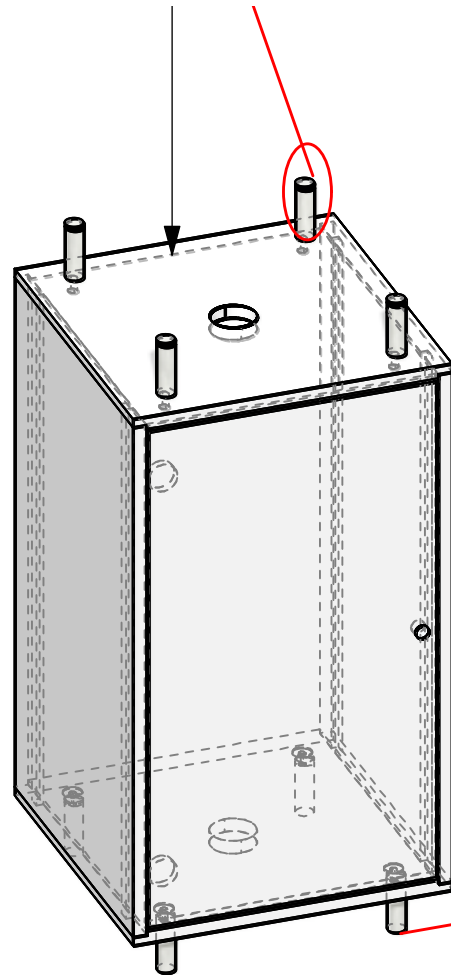

1. Redesign of this exhibit without approval by manufacturer may result in dangerous and unsafe structures. Manufacturer disclaims any responsibility for redesigned exhibits it does not approve in writing.

2. Parts and components such as panels and extrusions are manufactured to metric sizing. Where ever possible sizes have been noted in feet and inches as well as in metric. Below is the imperial to metric sizing table as reference. "Nominal" refers to approximate size.

2400mm = (94 1/2")	Phone Line / Fax
2100mm = (82 5/8")	Internet connection
1800mm = (70 7/8")	Outlet
1500mm = (59")	Main Drop (point of distrution)
1200mm = (47 1/4")	
900mm = (35 1/2")	
600mm = (23 5/8")	
300mm = (11 7/8")	

--- Wire running under carpet

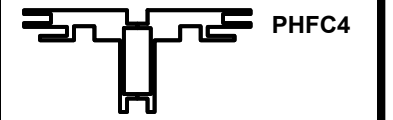
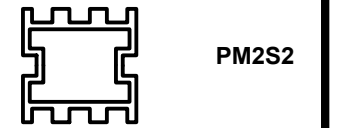

HYBRID PRO RENTAL KIT

Title: SET-UP INSTRUCTIONS

Code	#	Description
SS4	4	SILVER SS4 SHELF SUPPORTS
R-HPC-01-A-INT	1	2' X 2' X 5/8" INTERNAL SHELF FOR HPC-01-B

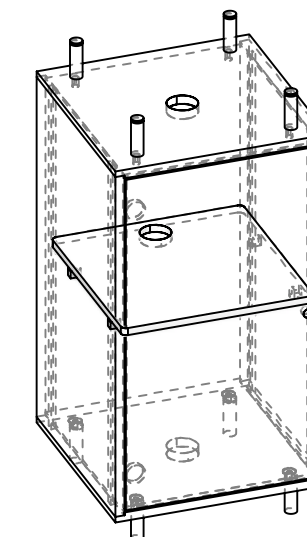
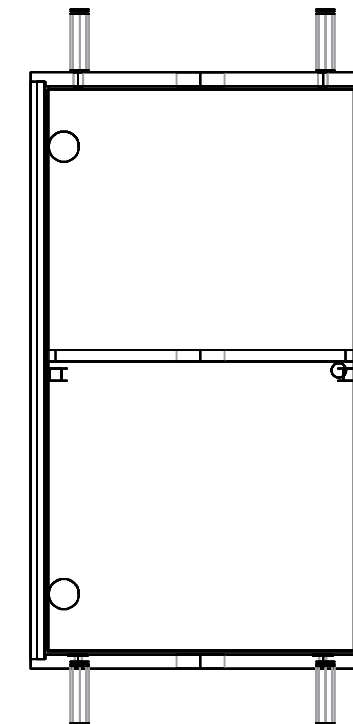
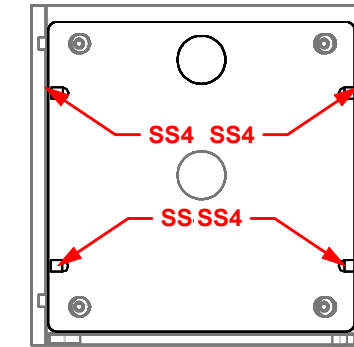
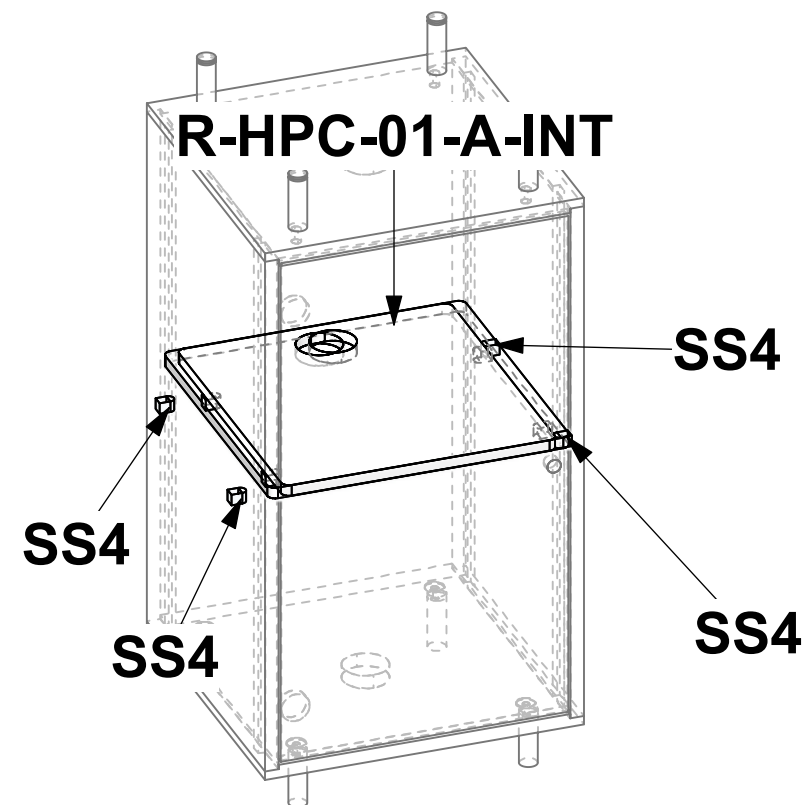
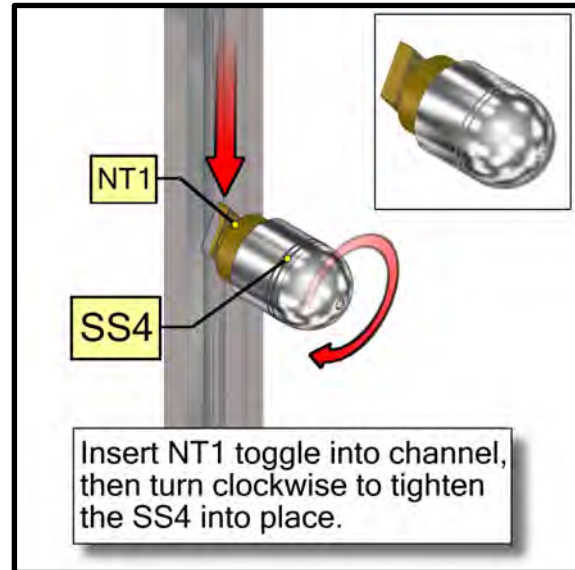

1. Redesign of this exhibit without approval by manufacturer may result in dangerous and unsafe structures. Manufacturer disclaims any responsibility for redesigned exhibits it does not approve in writing.

2. Parts and components such as panels and extrusions are manufactured to metric sizing. Where ever possible sizes have been noted in feet and inches as well as in metric. Below is the imperial to metric sizing table as reference. "Nominal" refers to approximate size.

2400mm = (94 1/2")	Phone Line / Fax
2100mm = (82 5/8")	Internet connection
1800mm = (70 7/8")	Outlet
1500mm = (59")	Main Drop (point of distrution)
1200mm = (47 1/4")	
900mm = (35 1/2")	
600mm = (23 5/8")	
300mm = (11 7/8")	

--- Wire running under carpet

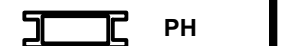
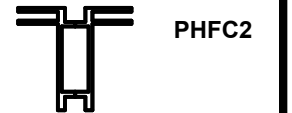
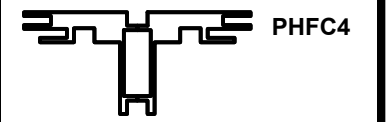
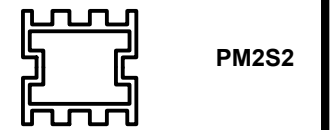

HYBRID PRO RENTAL KIT

Title: SET-UP INSTRUCTIONS

Code	#	Description
R-HPC-01-B-CT	1	4' X 2' X 2' L-SHAPED COUNTER TOP FOR R-HPC-01-A UNIT

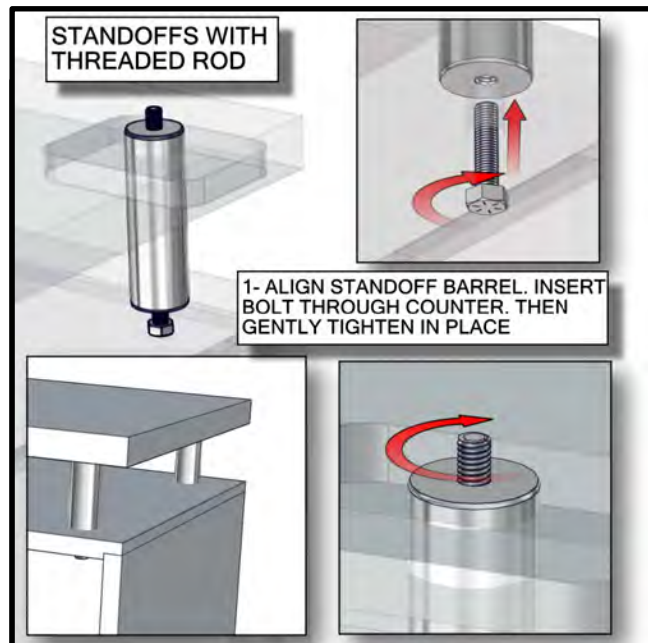

R-HPC-01-B-CT

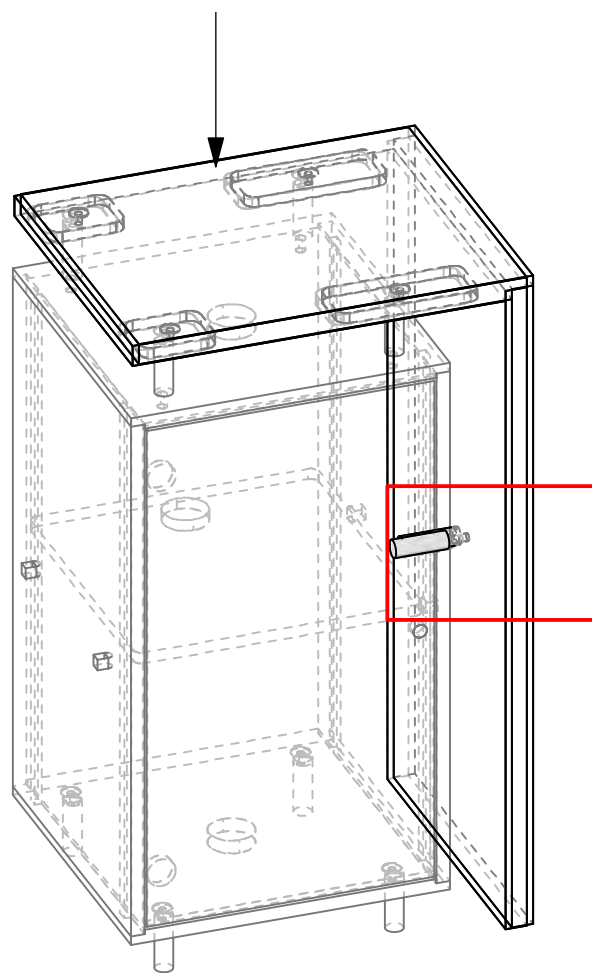

STANDOFF ATTACH TO "L" SHAPED COUNTER ONLY!

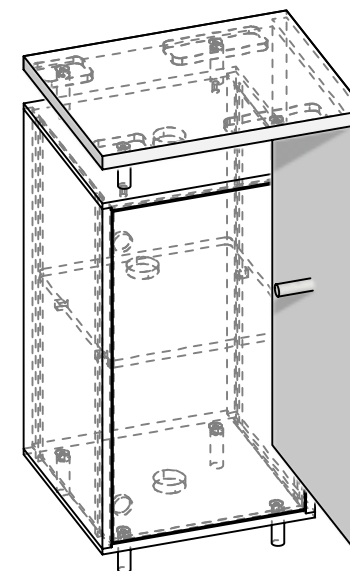
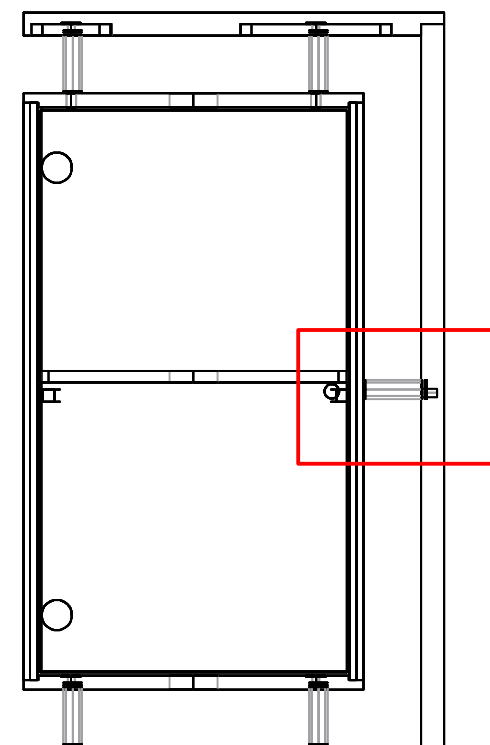
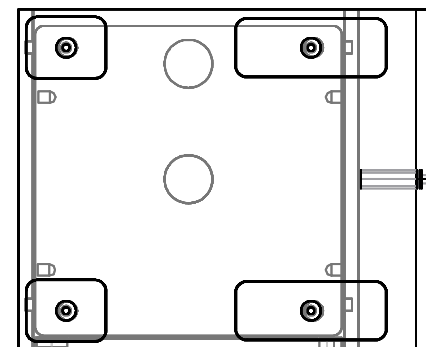

1. Redesign of this exhibit without approval by manufacturer may result in dangerous and unsafe structures. Manufacturer disclaims any responsibility for redesigned exhibits it does not approve in writing.

2. Parts and components such as panels and extrusions are manufactured to metric sizing. Where ever possible sizes have been noted in feet and inches as well as in metric. Below is the imperial to metric sizing table as reference. *Nominal* refers to approximate size.

2400mm = (94 1/2")	Phone Line / Fax
2100mm = (82 5/8")	Internet connection
1800mm = (70 7/8")	Outlet
1500mm = (59")	Main Drop (point of distrution)
1200mm = (47 1/4")	
900mm = (35 1/2")	
600mm = (23 5/8")	
300mm = (11 7/8")	

--- Wire running under carpet

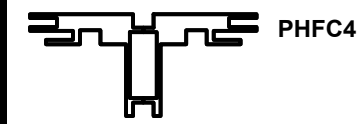
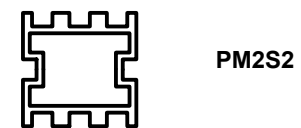

HYBRID PRO RENTAL KIT

Title: SET-UP INSTRUCTIONS





PACKING INSTRUCTIONS



1

1 R-HPC-01-B

CASE # 1

LEGEND	
	GREY FOAM FOLDED TO FILL EMPTY SPACES OR USED AS PROTECTION
	1/8" CARDBOARD SPACER (PUT IN BETWEEN EVERY PANEL)
	DIVIDER
	1/4" WHITE FOAM (USED AS PROTECTION DOOR PANELS W/ LOCKS)



WOODCRATE