

# Hybrid Pro Modular Kit 02

## HP-K-02

Hybrid Pro™ Modular exhibits and counters are a perfect solution for the serious exhibitor. Exhibits feature heavy-duty aluminum extrusion frames and push-fit fabric graphics. Count on making an unforgettable impact with Hybrid Pro Modular exhibit kits, counters, and accessories.



## features and benefits:

- Silver aluminum extrusion frame
- Single-sided SEG dye-sublimated fabric graphics
- Three literature holders
- Easy step-by-step instructions
- Kit includes frame, three fabric graphic panels, one table, two 200 LED floodlights, one medium monitor mount, three literature holders and two molded OCH2 cases
- Lifetime hardware warranty against manufacturer defects

## dimensions:

Hardware	Graphic
<p>Assembled unit: 115.63"w x 94.5"h x 42.88d 2937mm(w) x 2400.3(h) x 1089.15mm(d)</p> <p>Table: 21"w x 40.5"h x 19.7"d approx. 533.4mm(w) x 1028.7mm(h) x 500.38mm(d)</p> <p>Table holds max weight 25 lbs / 11.34 kgs</p>	<p>Total visual area: Panel A: 91.4"w x 94.375"h 2321.5mm(w) x 2397mm(h)</p> <p>Panel B: 11.68"w x 94.375"h 297mm(w) x 2397mm(h)</p> <p>Panel C: 69.04"w x 94.375"h 1753.6mm(w) x 2397mm(h)</p> <p>Please be sure to include a 2" bleed around the perimeter.</p>
<p>Shipping</p> <p>Shipping dimensions - ships in 2 cases: 2 OCH2 cases (each case): 52"l x 30"w x 14"h 1320.8mm(l) x 762mm(w) x 355.6mm(h)</p> <p>Approximate shipping weight (entire kit): 260 lbs / 118 kgs</p>	<p>Refer to related graphic templates for more information</p> <p>Visit: <a href="http://www.exhibitors-handbook.com/graphic-templates">www.exhibitors-handbook.com/graphic-templates</a></p>

## additional information:

Graphic material:  
Dye-sublimated fabric

Tabletop color options:



silver black mahogany natural

Lights Included:  
Lumina 200 LED floodlight, straight arm and adjustable head, black finish, 19.5" from end to end

Medium monitor bracket holds 26-40" LCD, maximum weight: 50 lbs / 22.68 kgs

We are continually improving and modifying our product range and reserve the right to vary the specifications without prior notice. All dimensions and weights quoted are approximate and we accept no responsibility for variance. E&OE. See Graphic Templates for graphic bleed specifications.

R-HP-K-02

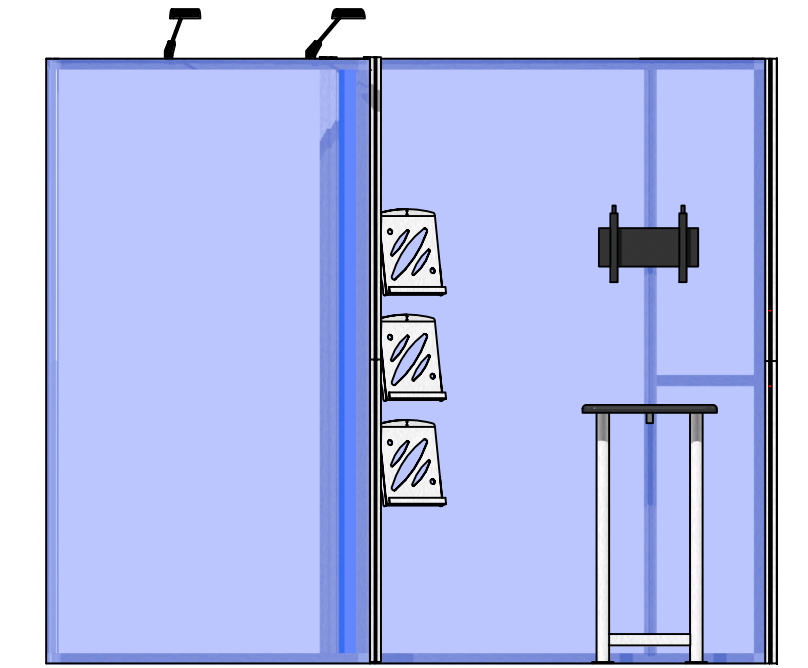
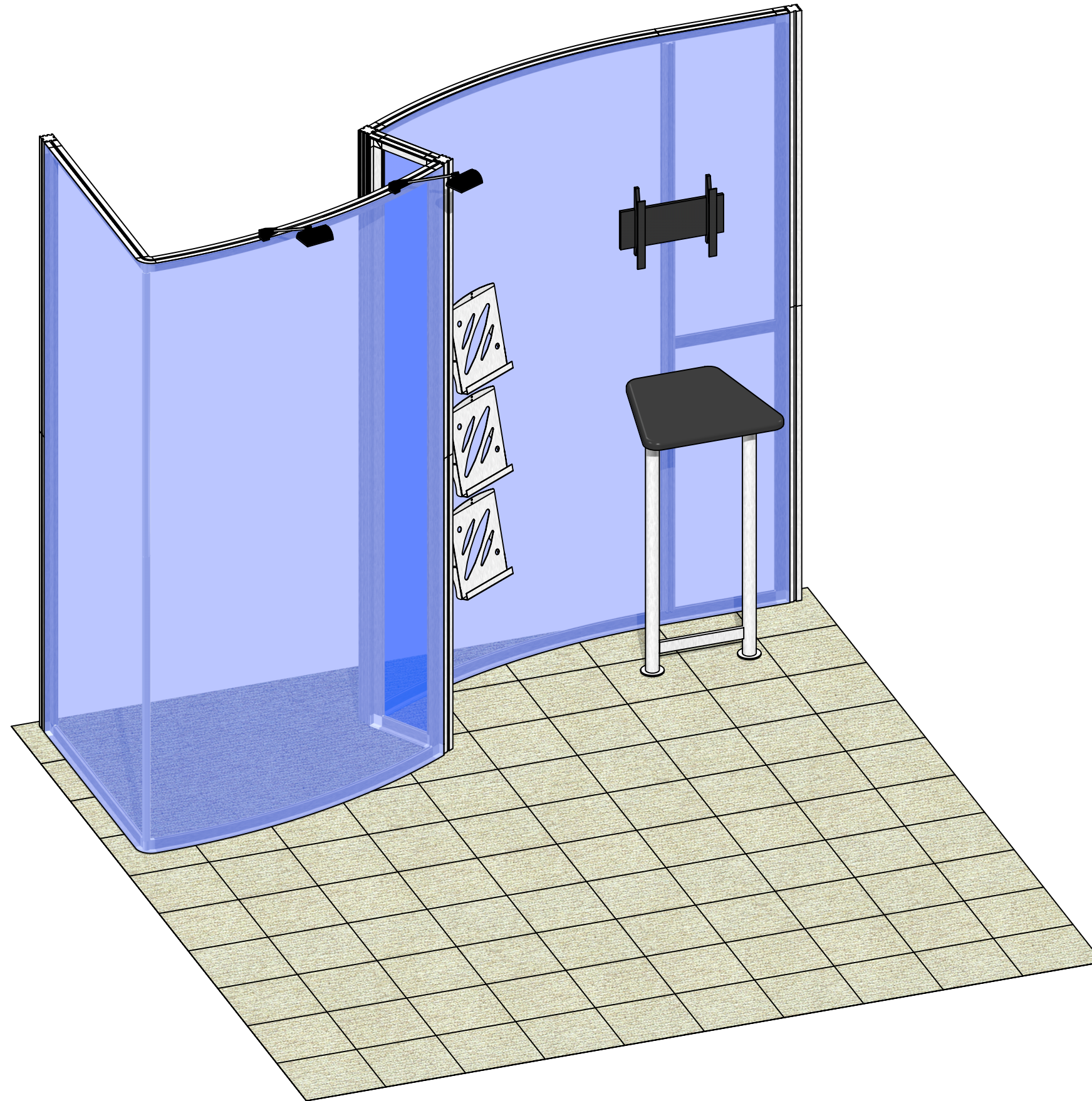

Code	#	Description
R49	2	PHFC2-8R-30 EXTRUSION WITH LOCKS 2 ENDS
R24	8	1200MM (47.24") 50MM50MM PM2S SQUARE EXTRUSION WITH STOP AT 155MM
R25	5	PH4SC-300MM (11.81") EXTRUSION WITH TENSION GLIDES
CB9-S	12	50MM SQUARE PHCF2 CORNER BRACKET
R19	12	1155MM (45.47") PHFC2 EXTRUSION WITH IB2 HOLE ONE SIDE-WITH LOCK 1 END WITH BIKE LOCKS
R21	2	PHFC2-8R-30 EXTRUSION WITH LOCKS 1 END
R16	2	900MM (35.43") PHFC2 EXTRUSION WITH LOCKS 2 ENDS
R17	2	450MM (17.72") PHFC2 EXTRUSION WITH IB2 HOLE ONE SIDE-WITH LOCK 1 END
R22	2	1155MM (45.47") 50MM50MM PM2R8 8 WAY ROUND EXTRUSION WITH STOP AT 155MM WITH LOCK 1 END
LN112	3	UNIVERSAL BROCHURE HOLDER WITH THUMB SCREW AND SUPPORT BAR
LN112	3	A4 UNIVERSAL LITERATURE HOLDER
LEDL10B	2	LED SPOTLIGHT,3M,UL PLUG W/TRANSFORMER BLACK
R8	1	300MM (11 13/16") PH WITH SLIDE LOCK AT BOTH ENDS
V-LG-05	1	1005MM X 425MM (39 9/16" X 16 3/4") RECTANGLE LEG 50MM CHANNEL
V-WS-CT-01	1	500MM X 538MM (19 11/16" X 21 3/16") TAPERED WORKSTATION TOP
IB2	8	PH INLINE CONNECTOR
R23	1	381MM (15") PH EXTRUSION WITH LOCKS 2 ENDS
CB10-R	2	50MM ROUND PHCF2 CORNER BRACKET
R108	2	1155MM LENGTH 30mm (1.18 Inch) TUBE
TC-30-S	1	INLINE CONNECTOR FOR 30 TUBING
R18	2	210MM (8.27") PHFC2 EXTRUSION WITH IB2 HOLE ONE SIDE-WITH LOCK 1 END
GRAPHIC C	1	94.5"H X 69.172"W SINGLE SIDED DYESUB GRAPHIC W/FCE-2 ON PERIMETER
GRAPHIC A	1	94.5"H X 91.53"W SINGLE SIDED DYESUB GRAPHIC W/FCE-2 ON PERIMETER
GRAPHIC B	1	94.5"H X 11.81"W SINGLE SIDED DYESUB GRAPHIC W/FCE-2 ON PERIMETER
MM-MB	1	MEDIUM MONITOR BRACKET FOR MONITORS 15"-40"

# BOM

R-HP-K-02

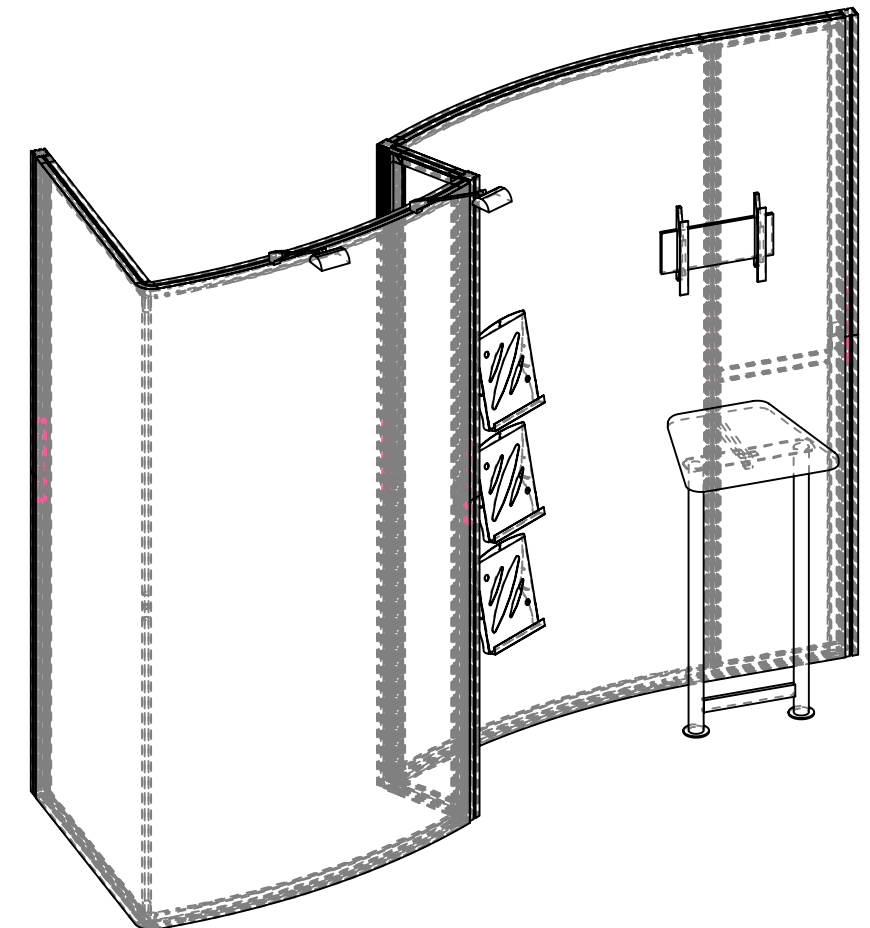
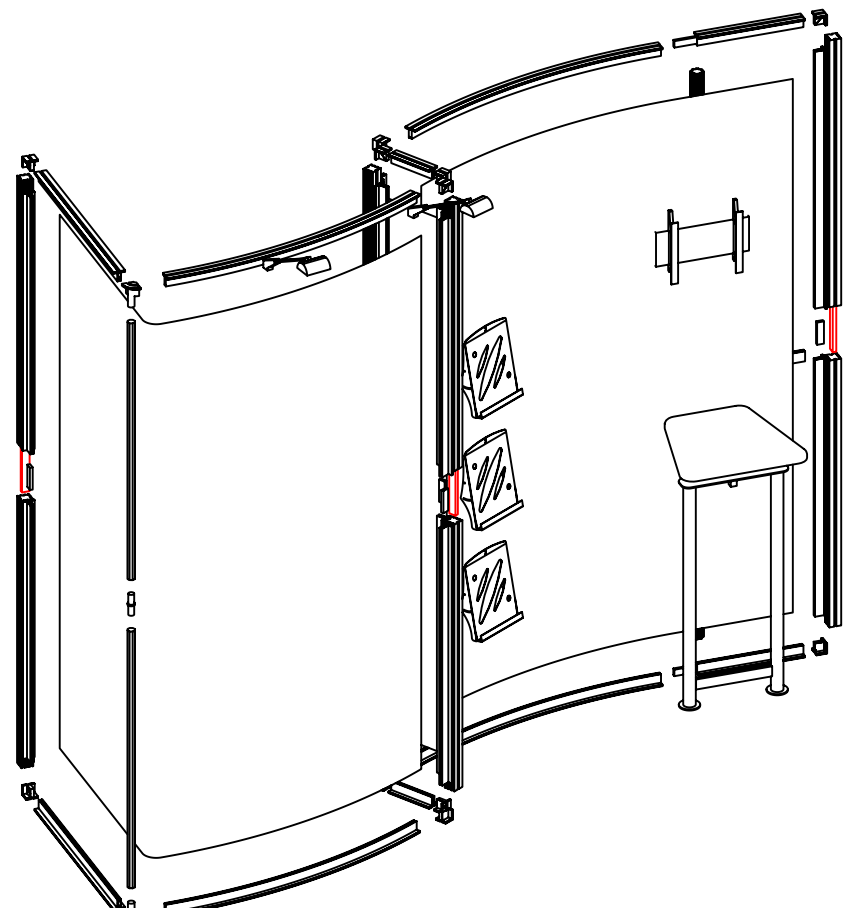
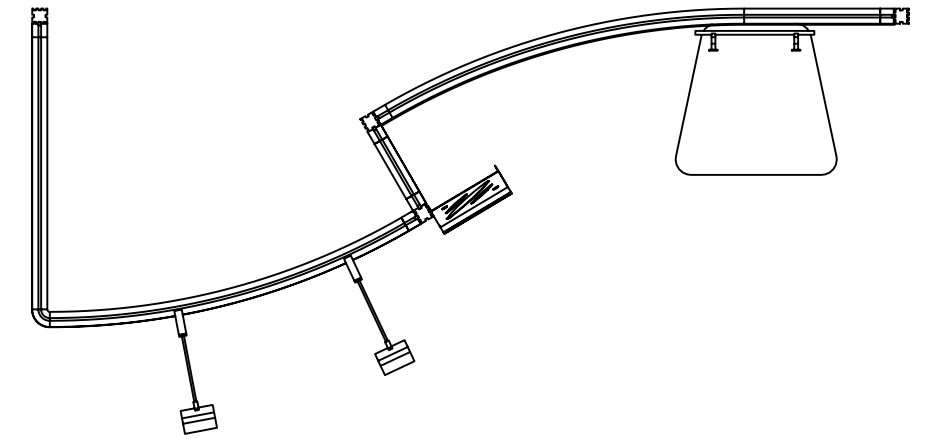

1. Redesign of this exhibit without approval by manufacturer may result in dangerous and unsafe structures. Manufacturer disclaims any responsibility for redesigned exhibits it does not approve in writing.

2. Parts and components such as panels and extrusions are manufactured to metric sizing. Where ever possible sizes have been noted in feet and inches as well as in metric. Below is the imperial to metric sizing table as reference. "Nominal" refers to approximate size.

- |                    |                                   |
|--------------------|-----------------------------------|
| 2400mm = (94 1/2") | ▼ Phone Line / Fax                |
| 2100mm = (82 5/8") | ▼ Internet connection             |
| 1800mm = (70 7/8") | ▼ Outlet                          |
| 1500mm = (59")     | ▼ Main Drop (point of distrution) |
| 1200mm = (47 1/4") |                                   |
| 900mm = (35 1/2")  |                                   |
| 600mm = (23 5/8")  |                                   |
| 300mm = (11 7/8")  |                                   |
- Wire running under carpet

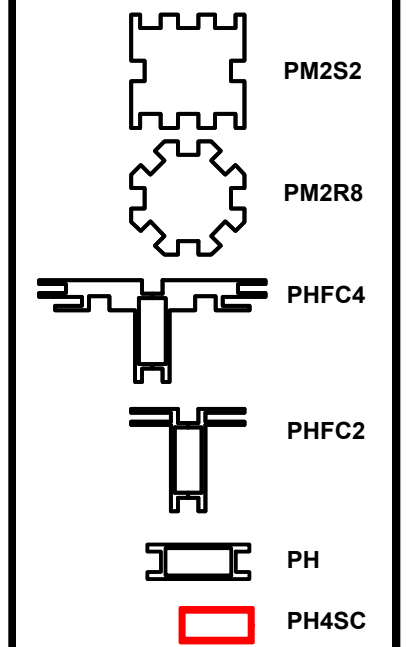
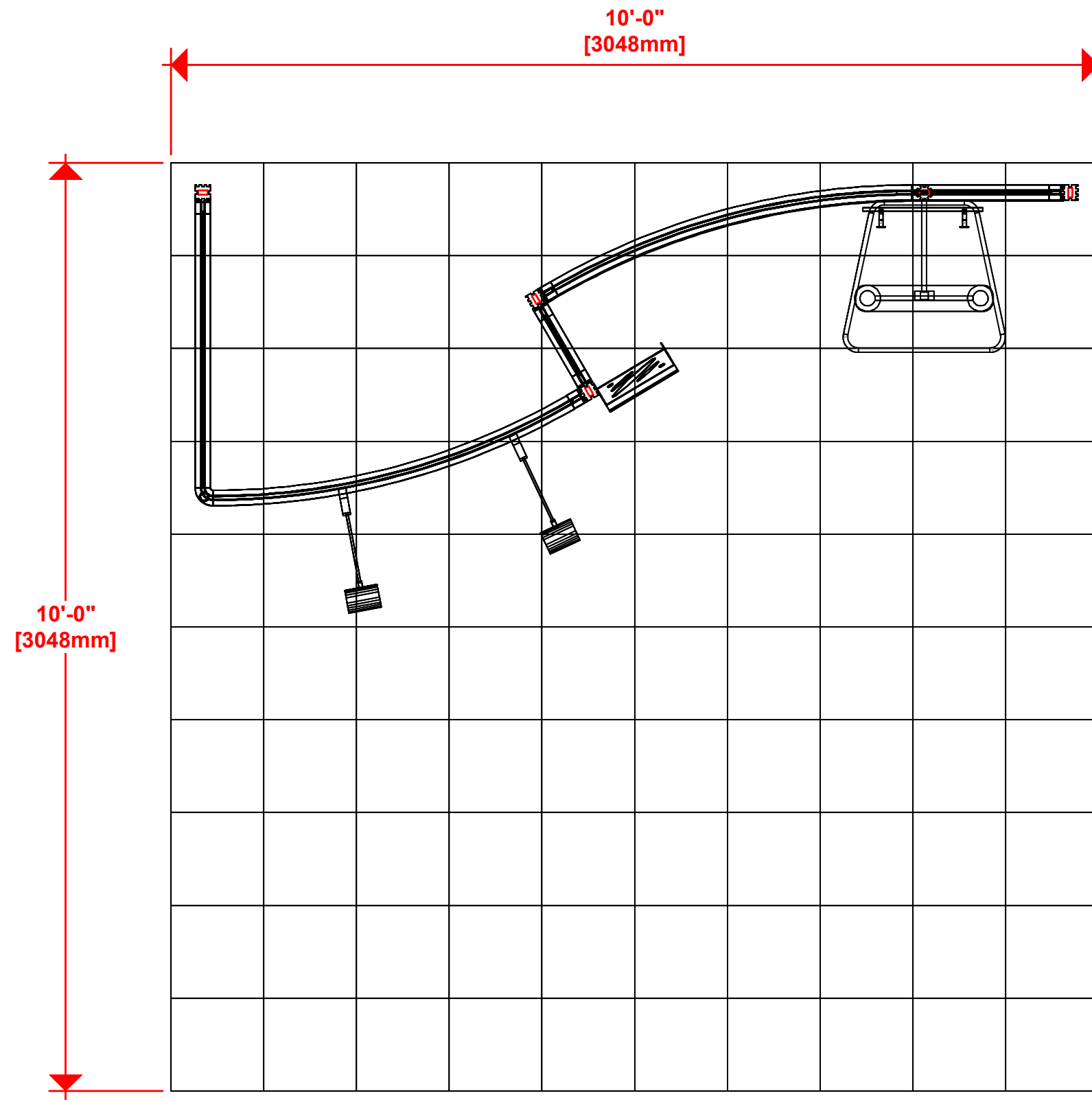

**HYBRID PRO RENTAL KIT**

Title: SET-UP INSTRUCTIONS

**(2) LEDL 10S LIGHTS = 50W PER STICK**

Code	#	Description
R49	2	PHFC2-8R-30 EXTRUSION WITH LOCKS 2 ENDS
CB9-S	4	50MM SQUARE PHCF2 CORNER BRACKET
R19	4	1155MM (45.47") PHFC2 EXTRUSION WITH IB2 HOLE ONE SIDE-WITH LOCK 1 END WITH SIDE LOCKS
R16	2	900MM (35.43") PHFC2 EXTRUSION WITH LOCKS 2 ENDS
IB2	2	PH INLINE CONNECTOR
CB10-R	2	50MM ROUND PHCF2 CORNER BRACKET
R108	2	1155MM LENGTH 30mm (1.18 Inch) TUBE
TC-30-S	1	INLINE CONNECTOR FOR 30 TUBING

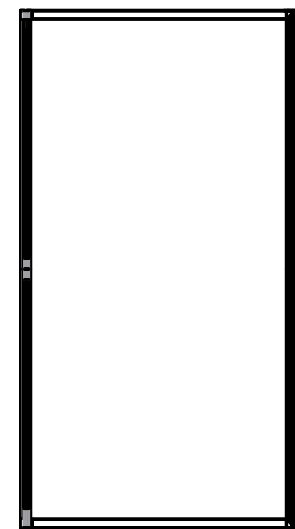
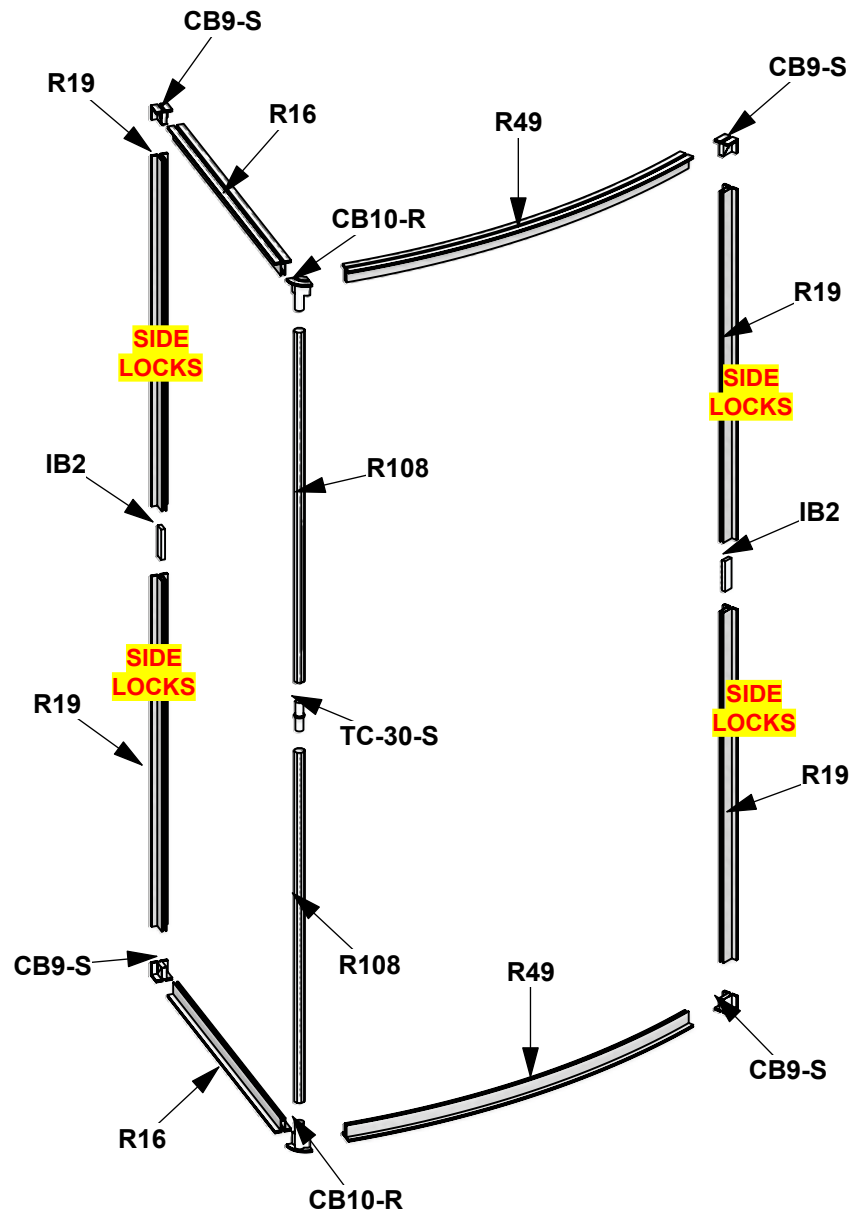

**WARNING!**  
Locks should ONLY be turned a quarter turn, so as not to STRIP the locks by over torquing them

**LOCK EXTRUSION BY USING 5MM HEX KEY**

1-Slide the IB2 into extrusion.  
2-Then tighten the screws to lock both extrusions together.

1. Redesign of this exhibit without approval by manufacturer may result in dangerous and unsafe structures. Manufacturer disclaims any responsibility for redesigned exhibits it does not approve in writing.

2. Parts and components such as panels and extrusions are manufactured to metric sizing. Where ever possible sizes have been noted in feet and inches as well as in metric. Below is the imperial to metric sizing table as reference. "Nominal" refers to approximate size.

2400mm = (94 1/2")	Phone Line / Fax
2100mm = (82 5/8")	Internet connection
1800mm = (70 7/8")	Outlet
1500mm = (59")	Main Drop (point of distrution)
1200mm = (47 1/4")	
900mm = (35 1/2")	
600mm = (23 5/8")	
300mm = (11 7/8")	

--- Wire running under carpet

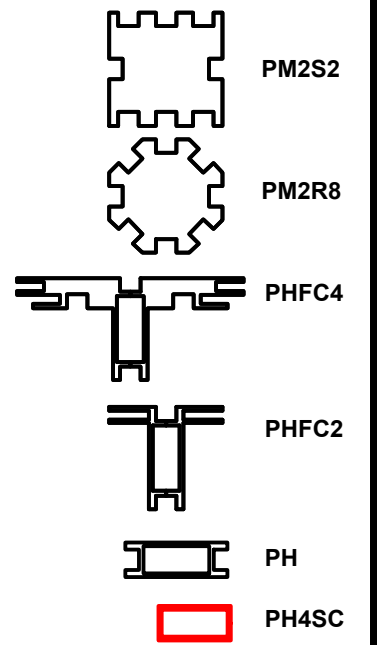

**HYBRID PRO RENTAL KIT**

Title: SET-UP INSTRUCTIONS

Code	#	Description
R24	4	1200MM (47.24") 50MM50MM PM2S SQUARE EXTRUSION WITH STOP AT 155MM
R25	2	PH4SC-300MM (11.81") EXTRUSION WITH TENSION GLIDES

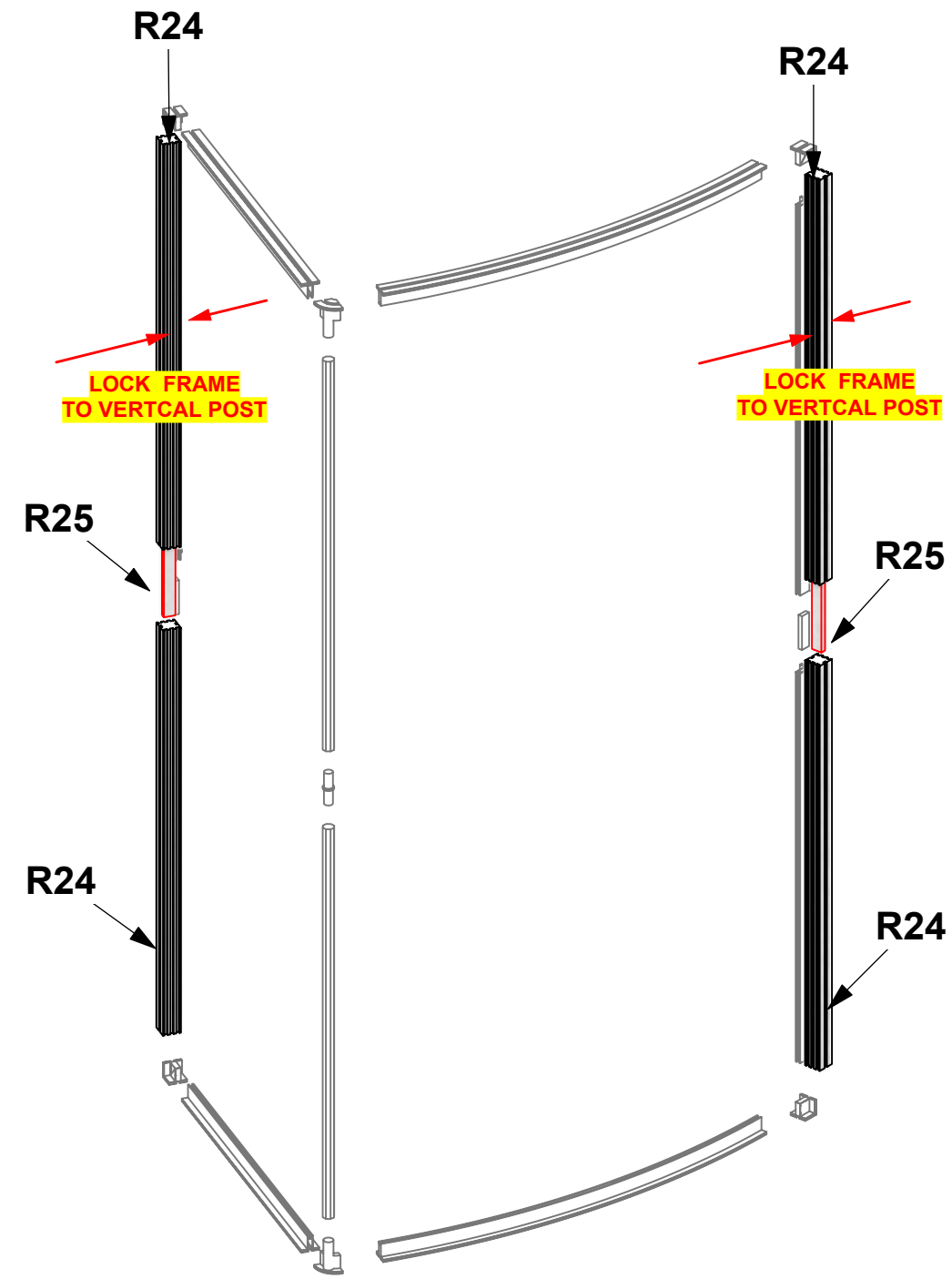
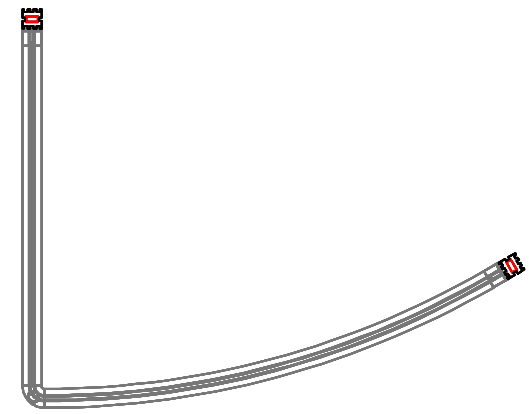
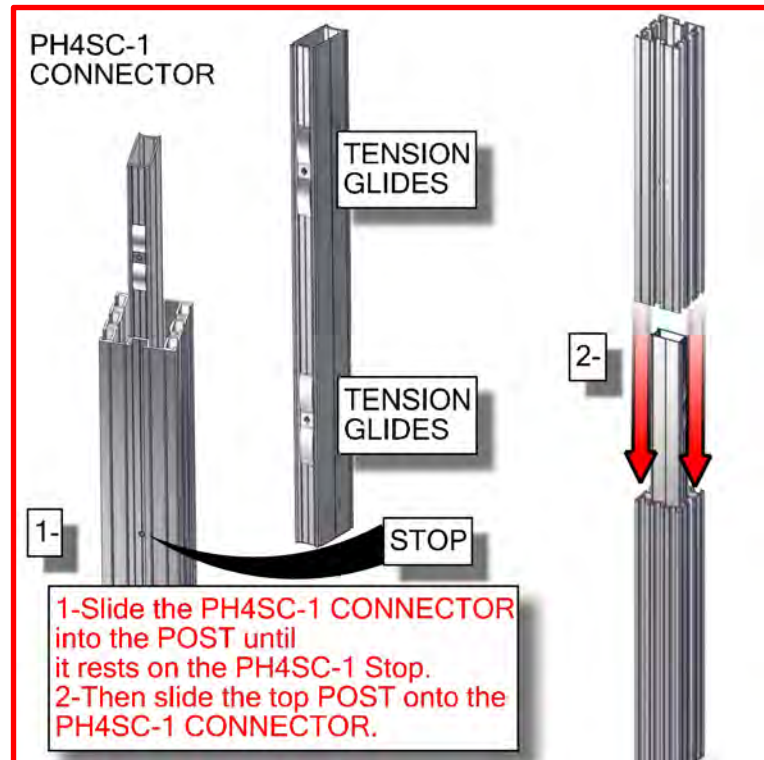
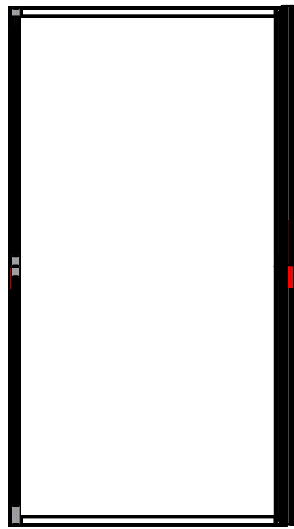

1. Redesign of this exhibit without approval by manufacturer may result in dangerous and unsafe structures. Manufacturer disclaims any responsibility for redesigned exhibits it does not approve in writing.

2. Parts and components such as panels and extrusions are manufactured to metric sizing. Where ever possible sizes have been noted in feet and inches as well as in metric. Below is the imperial to metric sizing table as reference. "Nominal" refers to approximate size.

2400mm = (94 1/2")	Phone Line / Fax
2100mm = (82 5/8")	Internet connection
1800mm = (70 7/8")	Outlet
1500mm = (59")	Main Drop (point of distrution)
1200mm = (47 1/4")	
900mm = (35 1/2")	
600mm = (23 5/8")	
300mm = (11 7/8")	

--- Wire running under carpet

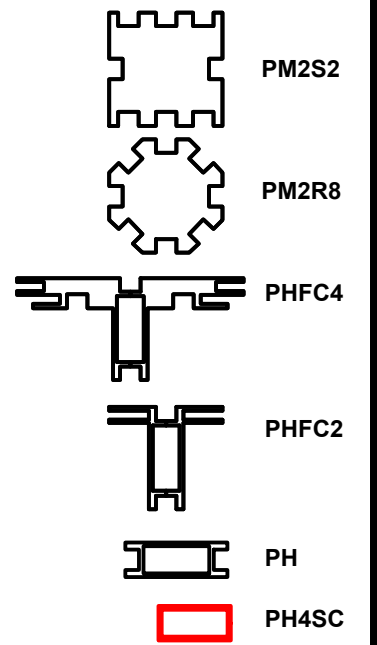

HYBRID PRO RENTAL KIT

Title: SET-UP INSTRUCTIONS

Code	#	Description
CB9-S	4	50MM SQUARE PHCF2 CORNER BRACKET
R19	4	1155MM (45.47") PHFC2 EXTRUSION WITH IB2 HOLE ONE SIDE-WITH LOCK 1 END WITH SIDE LOCKS
IB2	2	PH INLINE CONNECTOR
R18	2	210MM (8.27") PHFC2 EXTRUSION WITH IB2 HOLE ONE SIDE-WITH LOCK 1 END

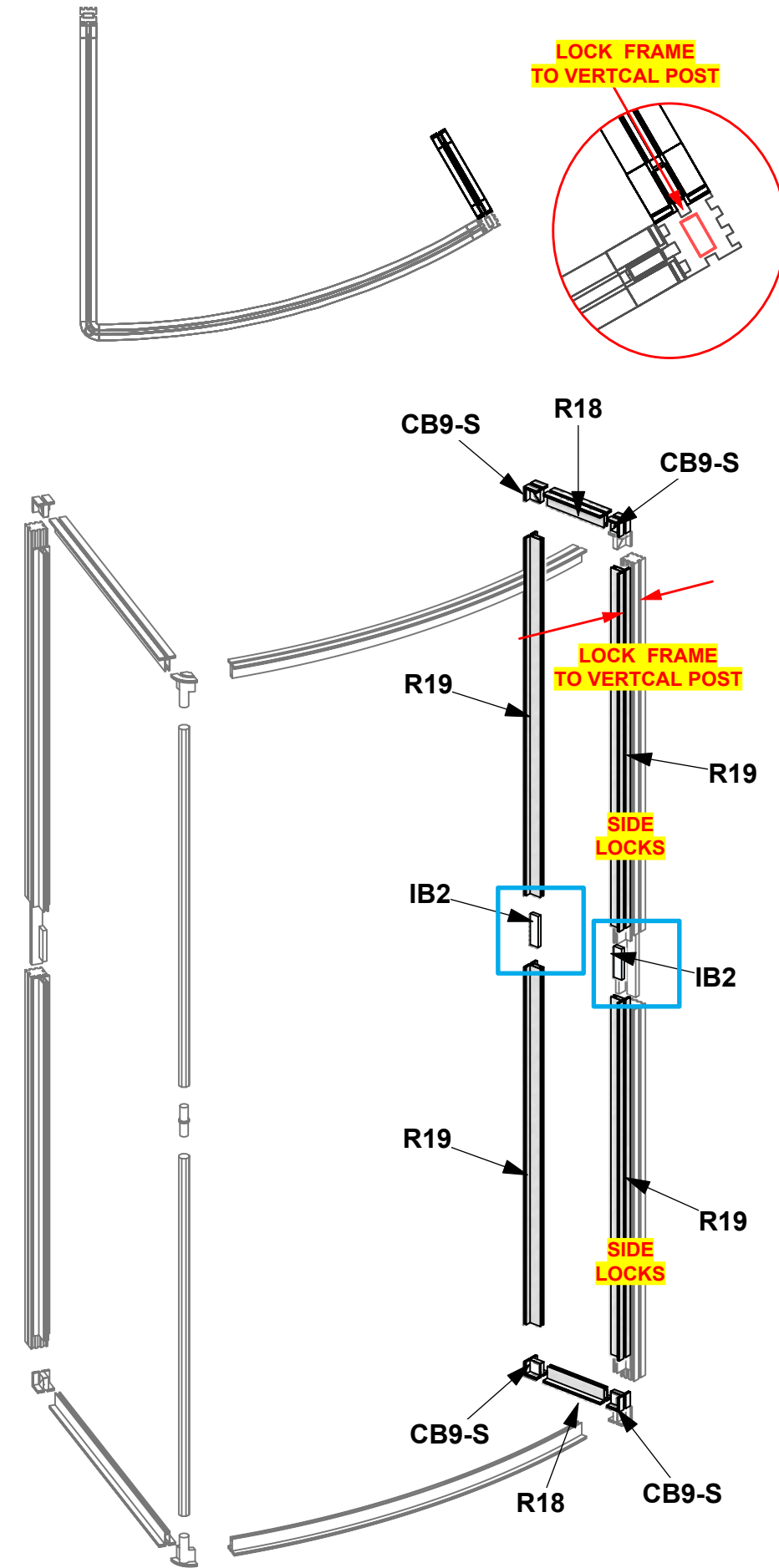
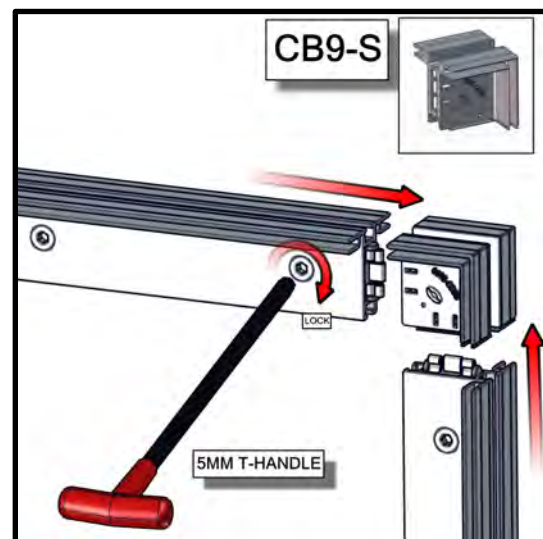
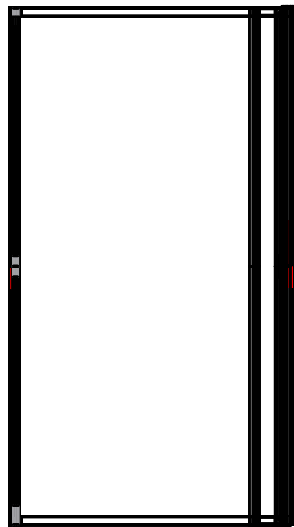

1. Redesign of this exhibit without approval by manufacturer may result in dangerous and unsafe structures. Manufacturer disclaims any responsibility for redesigned exhibits it does not approve in writing.

2. Parts and components such as panels and extrusions are manufactured to metric sizing. Where ever possible sizes have been noted in feet and inches as well as in metric. Below is the imperial to metric sizing table as reference. "Nominal" refers to approximate size.

2400mm = (94 1/2")	Phone Line / Fax
2100mm = (82 5/8")	Internet connection
1800mm = (70 7/8")	Outlet
1500mm = (59")	Main Drop (point of distrution)
1200mm = (47 1/4")	
900mm = (35 1/2")	
600mm = (23 5/8")	
300mm = (11 7/8")	

--- Wire running under carpet

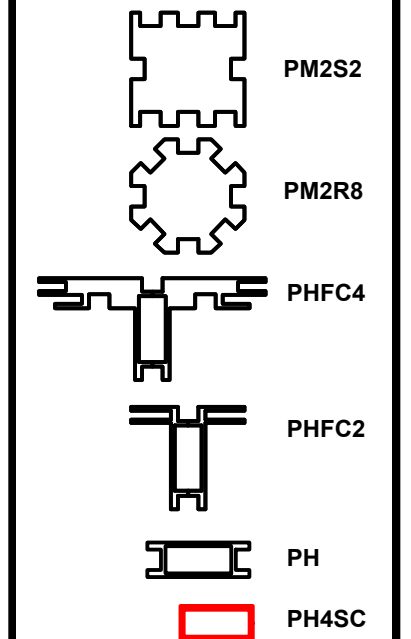

HYBRID PRO RENTAL KIT

Title: SET-UP INSTRUCTIONS

Code	#	Description
R24	2	1200MM (47.24") 50MM50MM PM2S SQUARE EXTRUSION WITH STOP AT 155MM
R25	1	PH4SC-300MM (11.81") EXTRUSION WITH TENSION GLIDES

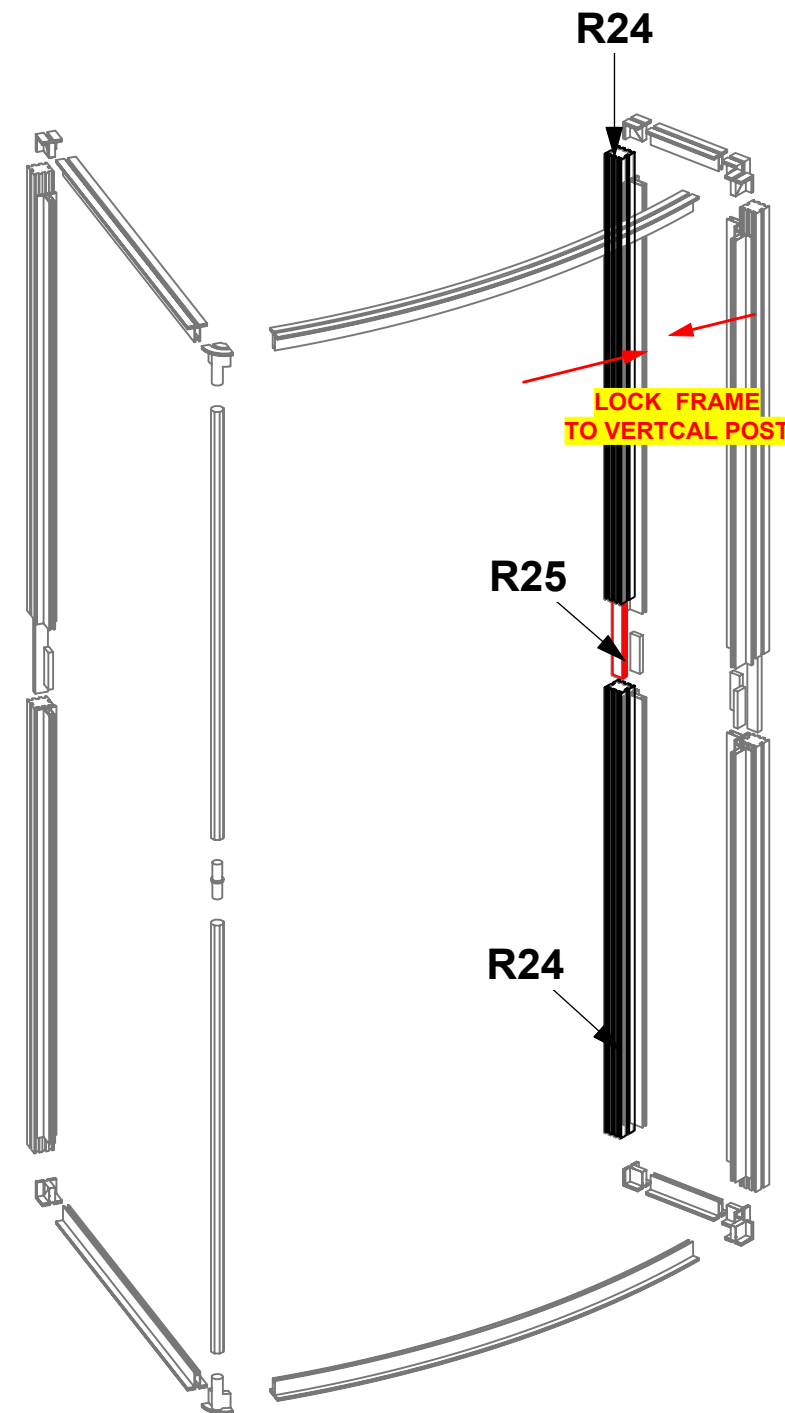
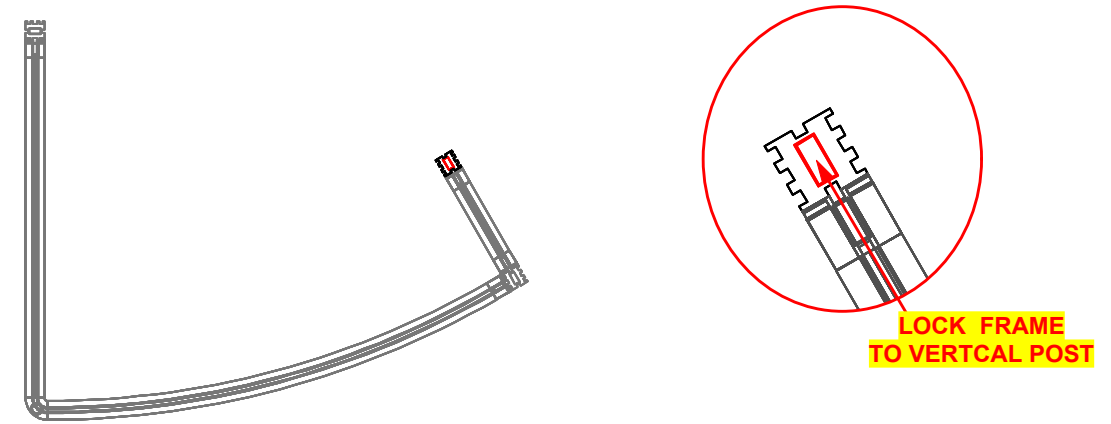
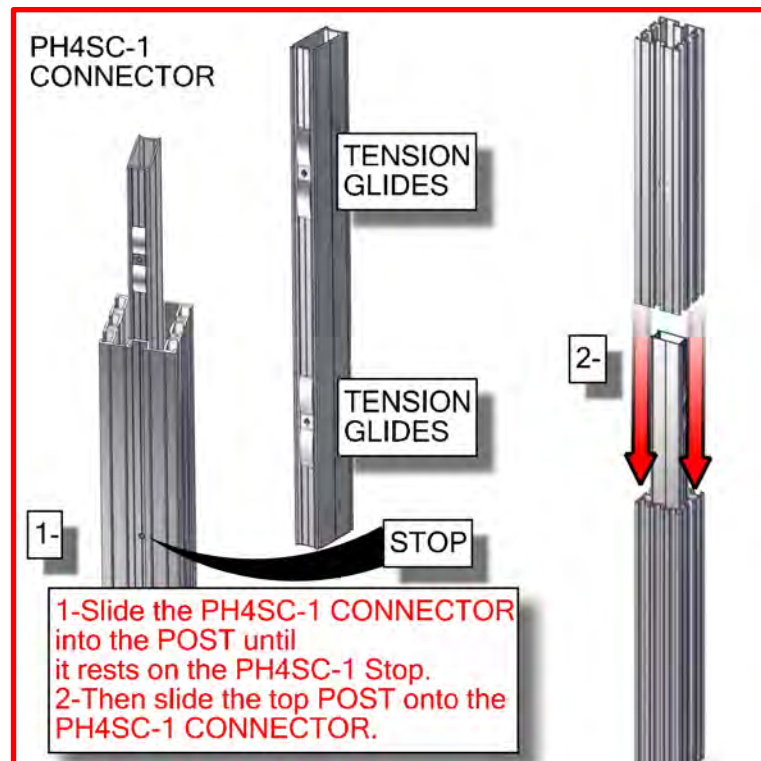
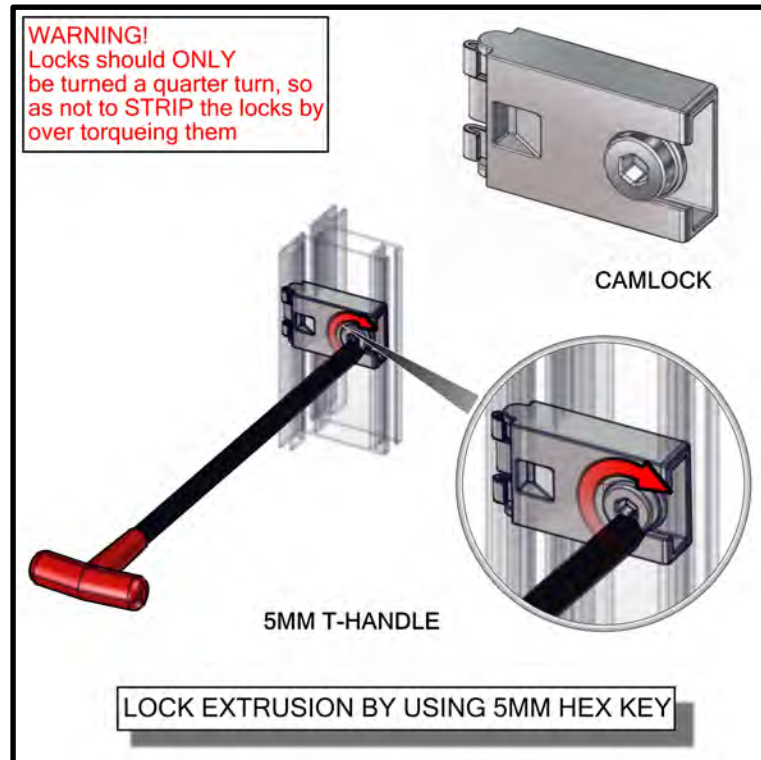

1. Redesign of this exhibit without approval by manufacturer may result in dangerous and unsafe structures. Manufacturer disclaims any responsibility for redesigned exhibits it does not approve in writing.

2. Parts and components such as panels and extrusions are manufactured to metric sizing. Where ever possible sizes have been noted in feet and inches as well as in metric. Below is the imperial to metric sizing table as reference. "Nominal" refers to approximate size.

2400mm = (94 1/2")	Phone Line / Fax
2100mm = (82 5/8")	Internet connection
1800mm = (70 7/8")	Outlet
1500mm = (59")	Main Drop (point of distrution)
1200mm = (47 1/4")	
900mm = (35 1/2")	
600mm = (23 5/8")	
300mm = (11 7/8")	

--- Wire running under carpet

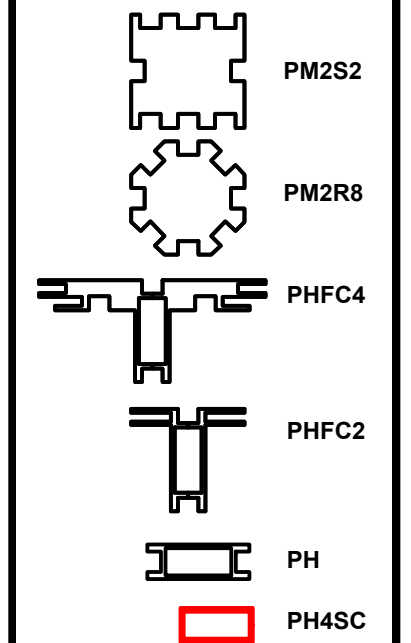

**HYBRID PRO RENTAL KIT**

Title: SET-UP INSTRUCTIONS



Code	#	Description
R21	2	PHFC2-8R-30 EXTRUSION WITH LOCKS 1 END
CB9-S	4	50MM SQUARE PHCF2 CORNER BRACKET
R19	4	1155MM (45.47") PHFC2 EXTRUSION WITH IB2 HOLE ONE SIDE-WITH LOCK 1 END WITH SIDE LOCKS
R24	2	1200MM (47.24") 50MM50MM PM2S SQUARE EXTRUSION WITH STOP AT 155MM
R25	2	PH4SC-300MM (11.81") EXTRUSION WITH TENSION GLIDES
R17	2	450MM (17.72") PHFC2 EXTRUSION WITH IB2 HOLE ONE SIDE-WITH LOCK 1 END
R22	2	1155MM (45.47") 50MM50MM PM2R8 8 WAY ROUND EXTRUSION WITH STOP AT 155MM WITH LOCK 1 END
IB2	4	PH INLINE CONNECTOR
R23	1	381MM (15") PH EXTRUSION WITH LOCKS 2 ENDS

1. Redesign of this exhibit without approval by manufacturer may result in dangerous and unsafe structures. Manufacturer disclaims any responsibility for redesigned exhibits it does not approve in writing.

2. Parts and components such as panels and extrusions are manufactured to metric sizing. Where ever possible sizes have been noted in feet and inches as well as in metric. Below is the imperial to metric sizing table as reference. "Nominal" refers to approximate size.

2400mm = (94 1/2")	Phone Line / Fax
2100mm = (82 5/8")	Internet connection
1800mm = (70 7/8")	Outlet
1500mm = (59")	Main Drop (point of distrution)
1200mm = (47 1/4")	
900mm = (35 1/2")	
600mm = (23 5/8")	
300mm = (11 7/8")	

--- Wire running under carpet

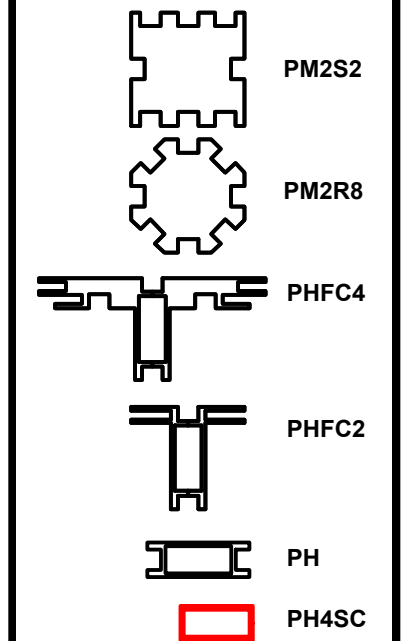

HYBRID PRO RENTAL KIT

Title: SET-UP INSTRUCTIONS

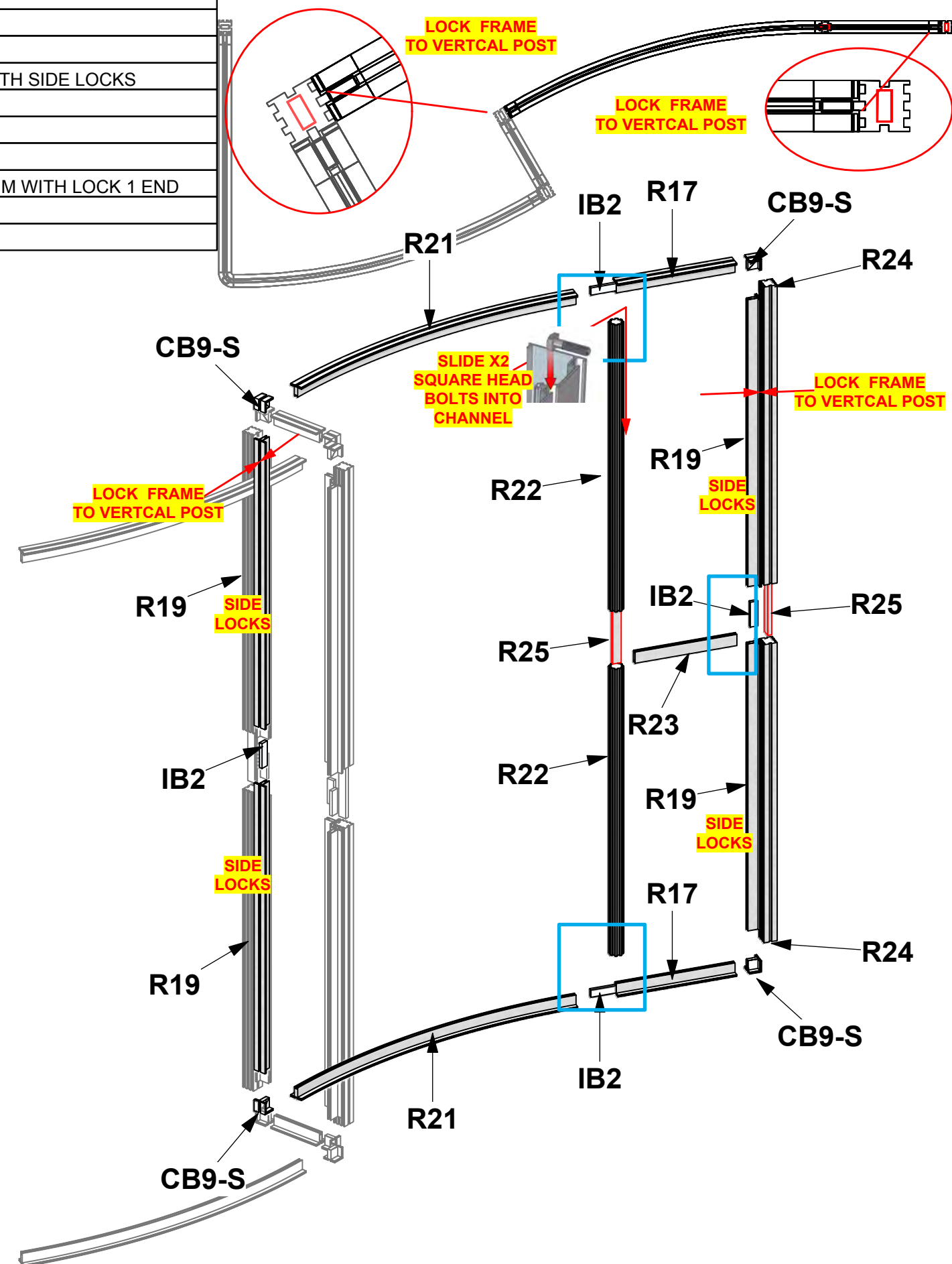
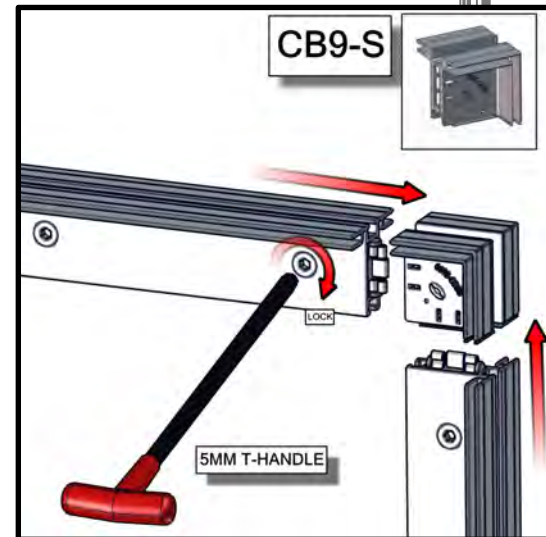
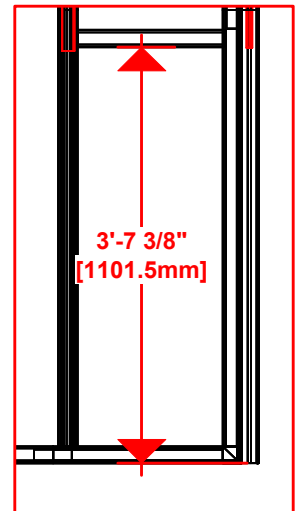

Code	#	Description
GRAPHIC C	1	94.5"H X 69.172"W SINGLE SIDED DYESUB GRAPHIC W/FCE-2 ON PERIMETER
GRAPHIC A	1	94.5"H X 91.53"W SINGLE SIDED DYESUB GRAPHIC W/FCE-2 ON PERIMETER
GRAPHIC B	1	94.5"H X 11.81"W SINGLE SIDED DYESUB GRAPHIC W/FCE-2 ON PERIMETER

1. Redesign of this exhibit without approval by manufacturer may result in dangerous and unsafe structures. Manufacturer disclaims any responsibility for redesigned exhibits it does not approve in writing.

2. Parts and components such as panels and extrusions are manufactured to metric sizing. Where ever possible sizes have been noted in feet and inches as well as in metric. Below is the imperial to metric sizing table as reference. "Nominal" refers to approximate size.

2400mm = (94 1/2")	Phone Line / Fax
2100mm = (82 5/8")	Internet connection
1800mm = (70 7/8")	Outlet
1500mm = (59")	Main Drop (point of distrution)
1200mm = (47 1/4")	
900mm = (35 1/2")	
600mm = (23 5/8")	
300mm = (11 7/8")	

--- Wire running under carpet

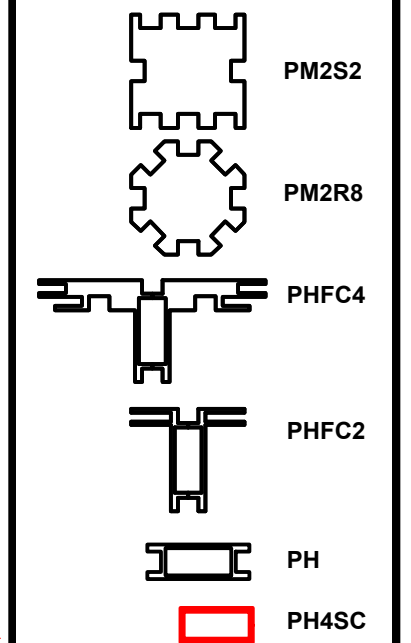

FCE-2 TO PHFC4

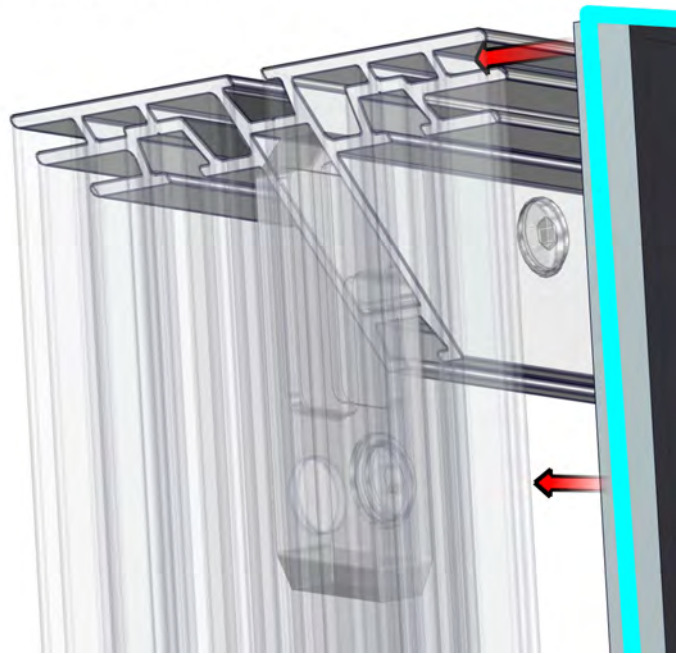

FCE-2 TO PHFC4

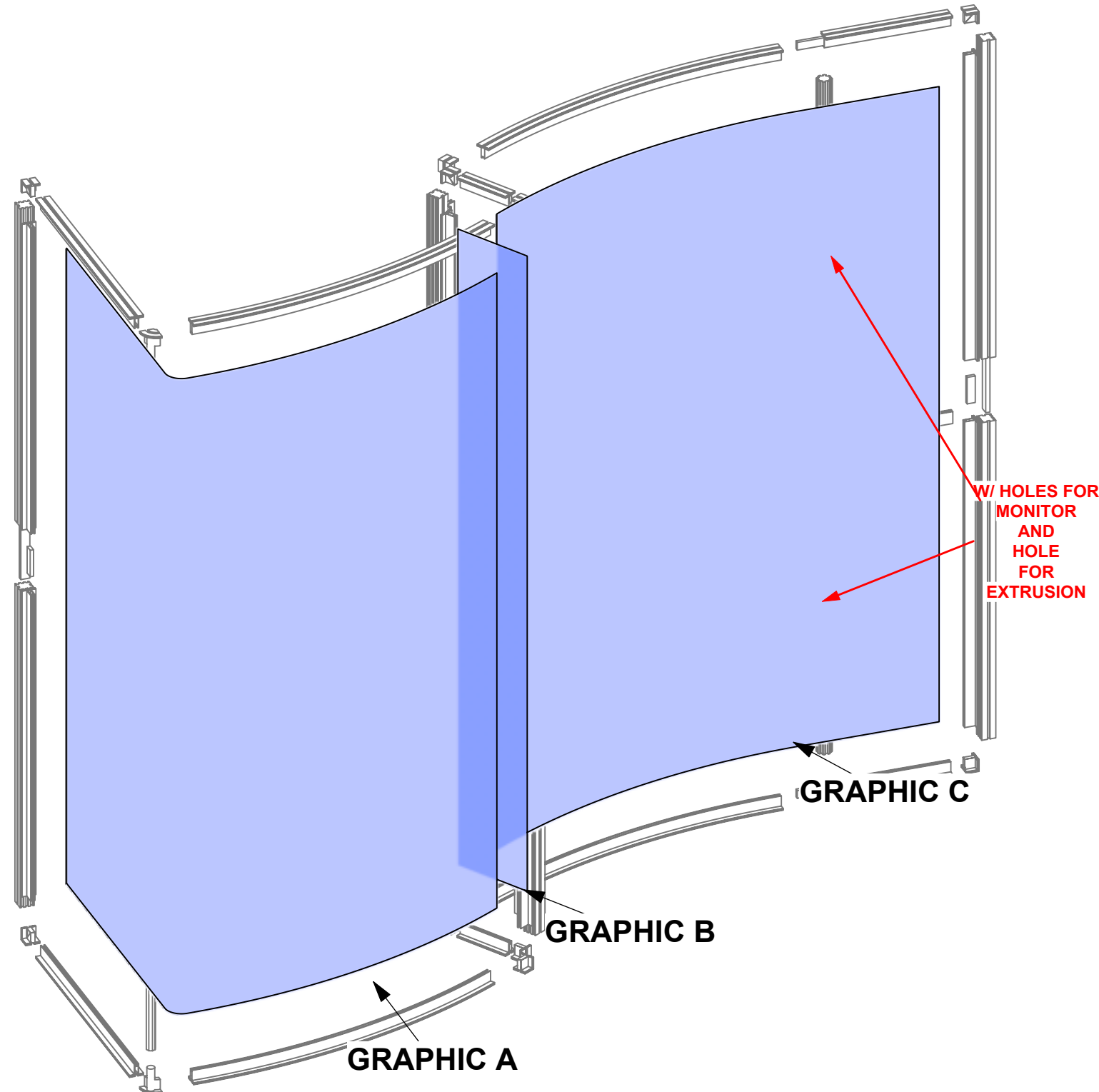
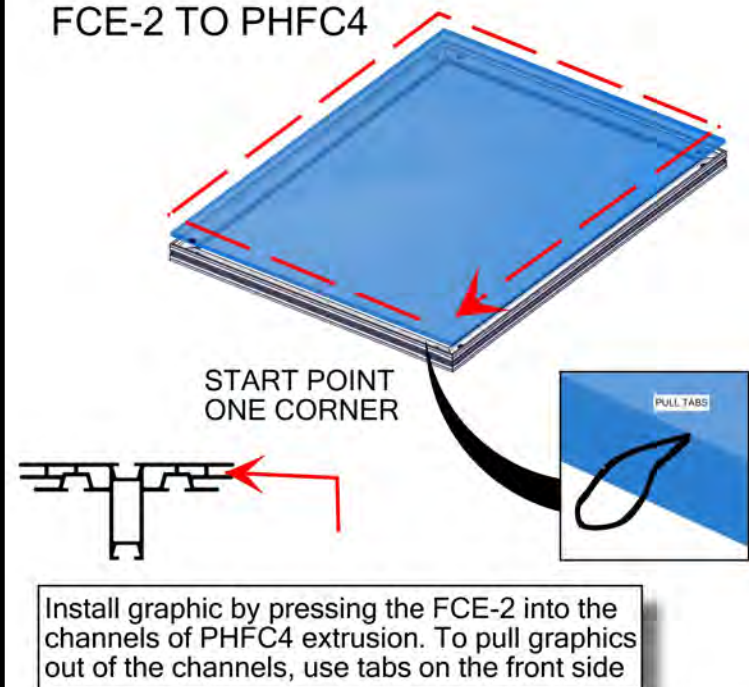



HYBRID PRO RENTAL KIT

Title: SET-UP INSTRUCTIONS

Code	#	Description
R8	1	300MM (11 13/16") PH WITH SLIDE LOCK AT BOTH ENDS
V-LG-05	1	1005MM X 425MM (39 9/16" X 16 3/4") RECTANGLE LEG 50MM CHANNEL
V-WS-CT-01	1	500MM X 538MM (19 11/16" X 21 3/16") TAPERED WORKSTATION TOP
MM-MB	1	MEDIUM MONITOR BRACKET FOR MONITORS 15"-40"

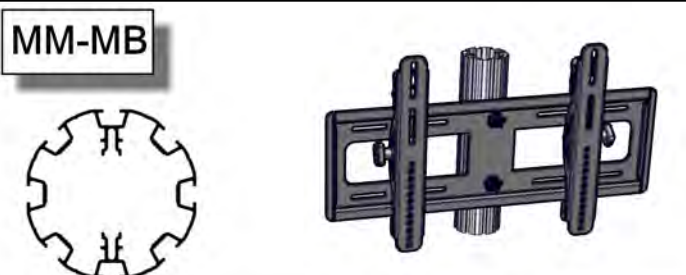
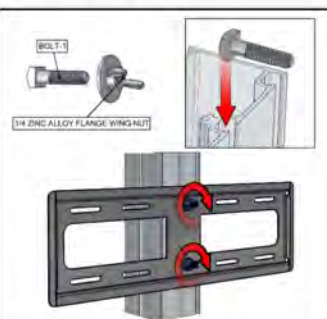
**MM-MB**

1- INSERT BOLTS INTO MIDDLE CHANNEL. THEN SECURE MONITOR MOUNT WITH WING NUTS.

2- ATTACH MONITOR TO BRACKETS SEE SANUS MANUAL FOR MORE INFO

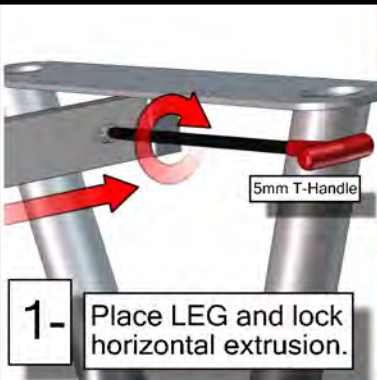

1- Place LEG and lock horizontal extrusion.

5mm T-Handle



thumb connector

2- Insert the thumb connector into the bottom of the counter top and make a 1/4 turn clockwise to tighten in place.

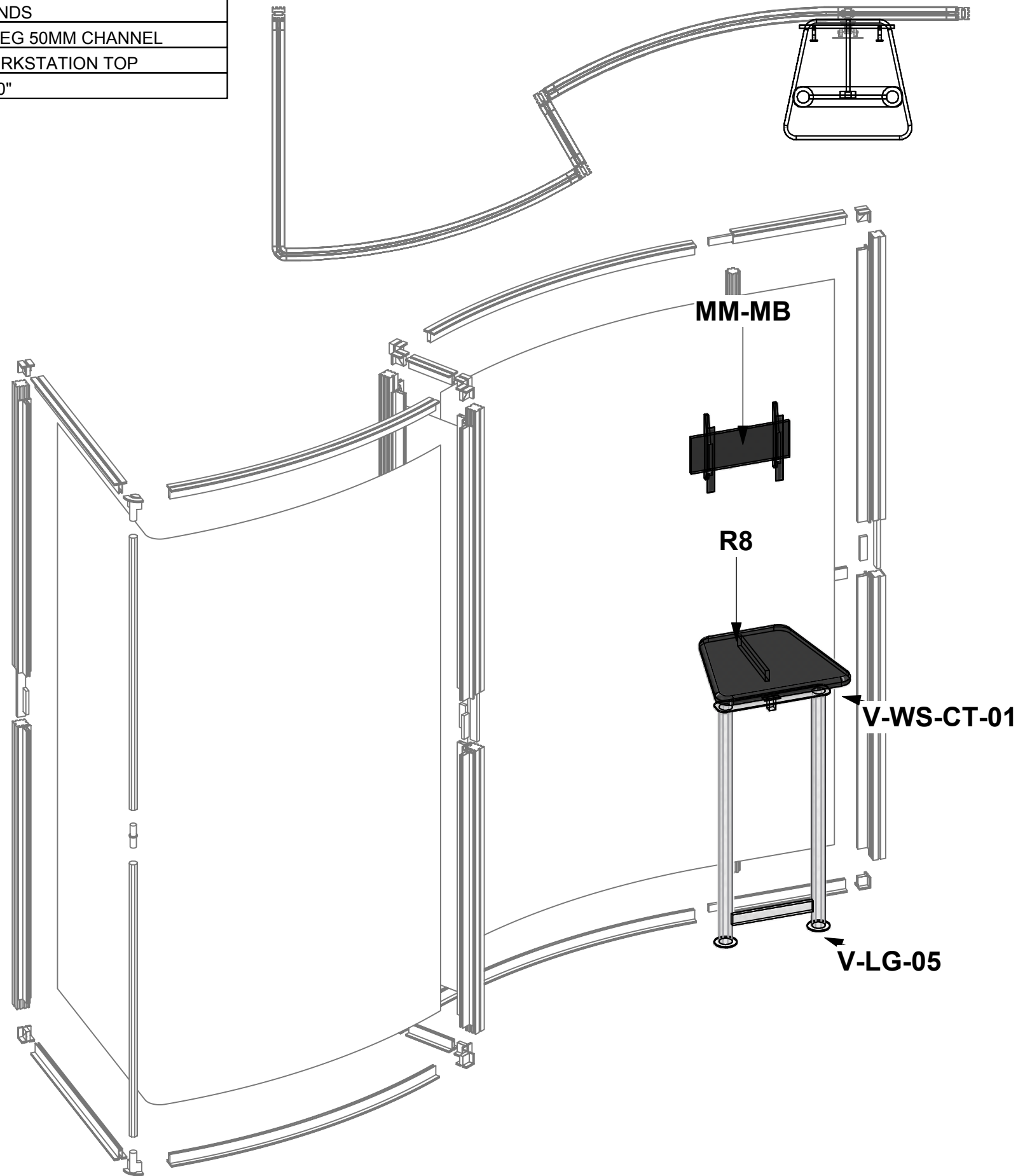

1. Redesign of this exhibit without approval by manufacturer may result in dangerous and unsafe structures. Manufacturer disclaims any responsibility for redesigned exhibits it does not approve in writing.

2. Parts and components such as panels and extrusions are manufactured to metric sizing. Where ever possible sizes have been noted in feet and inches as well as in metric. Below is the imperial to metric sizing table as reference. "Nominal" refers to approximate size.

2400mm = (94 1/2")	Phone Line / Fax
2100mm = (82 5/8")	Internet connection
1800mm = (70 7/8")	Outlet
1500mm = (59")	Main Drop (point of distrution)
1200mm = (47 1/4")	
900mm = (35 1/2")	
600mm = (23 5/8")	
300mm = (11 7/8")	

--- Wire running under carpet

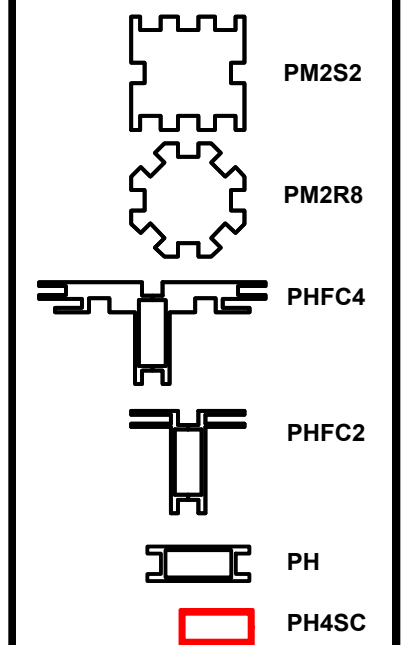

**HYBRID PRO RENTAL KIT**

Title: SET-UP INSTRUCTIONS

Code	#	Description
LN112	3	UNIVERSAL BROCHURE HOLDER WITH THUMB SCREW AND SUPPORT BAR
LN112	3	A4 UNIVERSAL LITERATURE HOLDER
LEDL10B	2	LED SPOTLIGHT,3M,UL PLUG W/TRANSFORMER BLACK

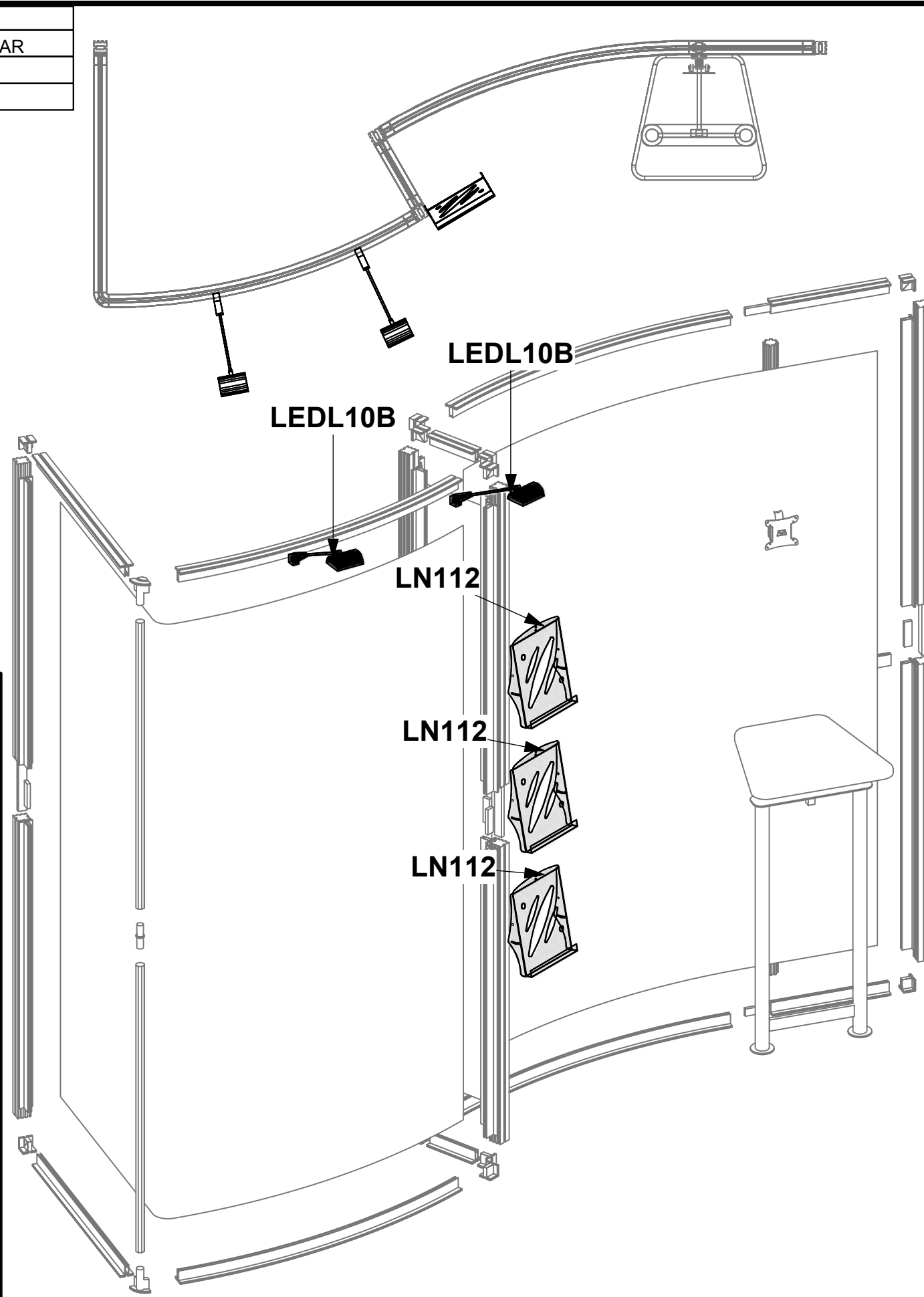
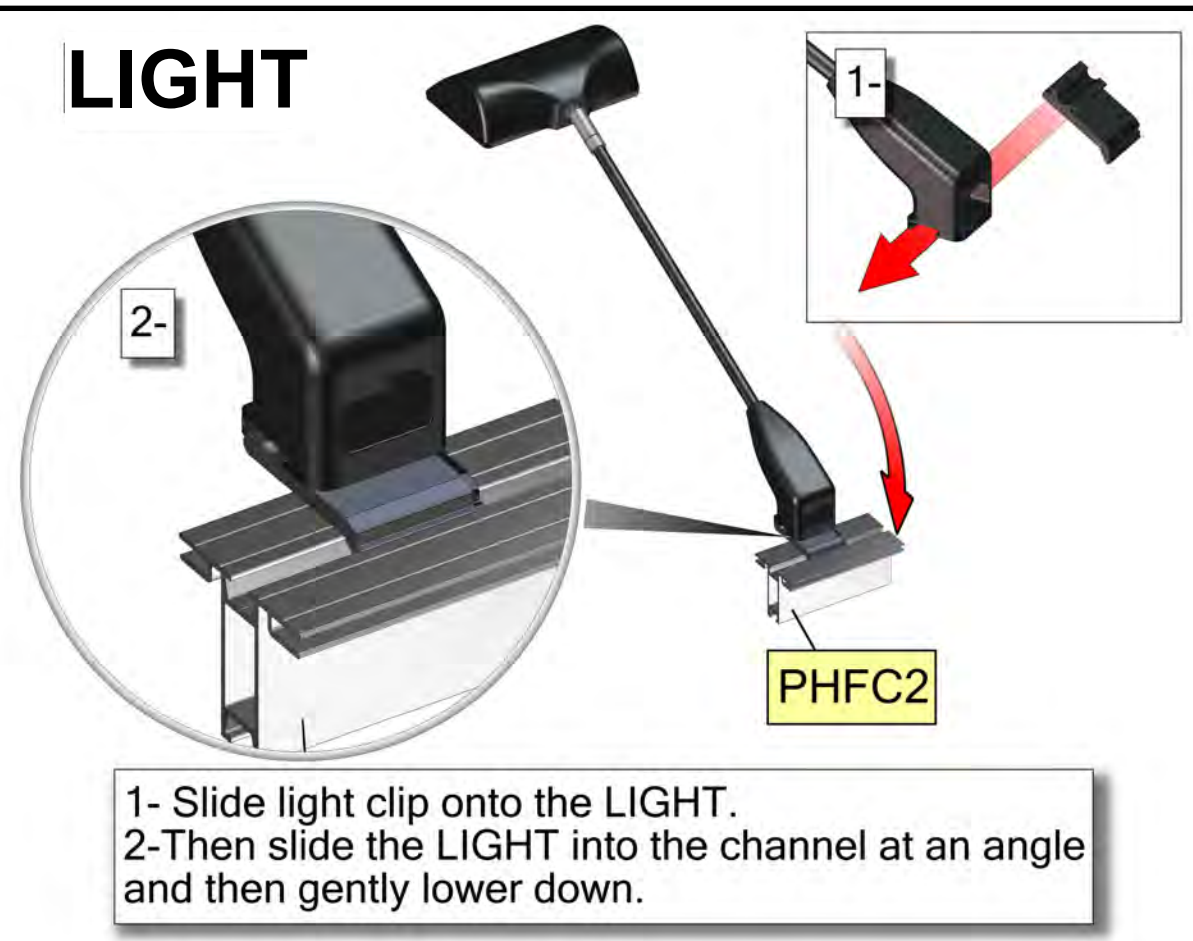
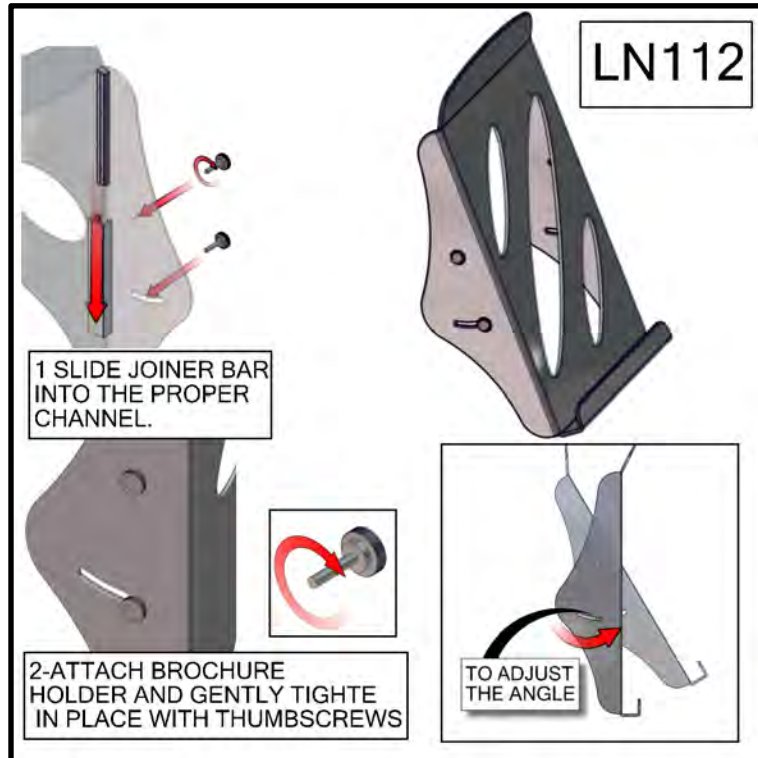

1. Redesign of this exhibit without approval by manufacturer may result in dangerous and unsafe structures. Manufacturer disclaims any responsibility for redesigned exhibits it does not approve in writing.

2. Parts and components such as panels and extrusions are manufactured to metric sizing. Where ever possible sizes have been noted in feet and inches as well as in metric. Below is the imperial to metric sizing table as reference. "Nominal" refers to approximate size.

2400mm = (94 1/2")	Phone Line / Fax
2100mm = (82 5/8")	Internet connection
1800mm = (70 7/8")	Outlet
1500mm = (59")	Main Drop (point of distrution)
1200mm = (47 1/4")	
900mm = (35 1/2")	
600mm = (23 5/8")	
300mm = (11 7/8")	

--- Wire running under carpet

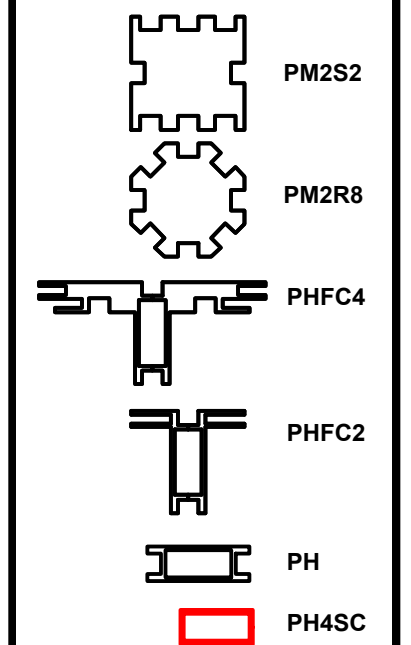

**HYBRID PRO RENTAL KIT**

Title: SET-UP INSTRUCTIONS

# **PACKING INSTRUCTIONS**



**1**  
 (2) TUBE-30-1155, (8) IB2, (2) CB10R,  
 (2) R19, (6) R25, (2) LED-10S LIGHTS,  
 (1) R23, (1) MM-MB

**2**  
 (2) R17, (12) CB9, (6) R19,  
 (6) R19, (2) K21, (2) R49,  
 (2) R18

**3**  
 (8) R24, (2) R22, (2) R19

**4**  
 (2) R19

# CASE # 1

<b>LEGEND</b>		GREY FOAM FOLDED TO FILL EMPTY SPACES OR USED AS PROTECTION
		1/8" CARDBOARD SPACER (PUT IN BETWEEN EVERY PANEL)
		DIVIDER
		1/4" WHITE FOAM (USED AS PROTECTION DOOR PANELS W/ LOCKS)





1

(1) STEAMER,  
(3) LN-112



2

(1) R9  
(1) V-WS-CT-01



3

(1) DV-LG-01

## CASE # 2

<b>LEGEND</b>		GREY FOAM FOLDED TO FILL EMPTY SPACES OR USED AS PROTECTION
		1/8" CARDBOARD SPACER (PUT IN BETWEEN EVERY PANEL)
		DIVIDER
		1/4" WHITE FOAM (USED AS PROTECTION DOOR PANELS W/ LOCKS)

