

# Freestanding iPad Stand

Black: PAD12-02A-BLACK

White: PAD12-02A-WHITE

Silver: PAD12-02A-SILVER

The Freestanding iPad Stand is a smart, lightweight and portable holder used to display the iPad 2nd, 3rd, 4th generations or Air. It can be positioned in either portrait or landscape configurations. Security screws, allen key and bolts make the unit both durable and theft resistant. For extra security, the base can also be bolted to the floor.



Portrait view



Landscape view



Back

We are continually improving and modifying our product range and reserve the right to vary the specifications without prior notice. All dimensions and weights quoted are approximate and we accept no responsibility for variance. E&OE. See Graphic Templates for graphic bleed specifications.

## features and benefits:

- Available in black, white or silver finish
- Holder compatible with 2nd, 3rd, 4th iPad generations, or iPad Air
- Can be positioned in either portrait or landscape view
- Made from steel
- Quick to set up
- Security screws/Allen key and bolts make unit both durable and theft resistant
- Unit can be bolted to floor
- One year hardware warranty against manufacturer defects

## dimensions:

### Hardware

Assembled unit:  
Landscape view:  
14.17" w x 41.14" h  
360mm(w) x 1045mm(h)

Portrait view:  
14.17" w x 41.73" h  
360mm(w) x 1060mm(h)

Weight:  
9.25 lbs / 4.2 kgs

### Shipping

Shipping dimensions - unit ships in 1 box:  
40.5" l x 15" w x 6" h  
1029mm(l) x 381mm(w) x 152mm(h)

Shipping weight:  
15 lbs / 6.8 kgs

## additional information:

\*iPad not included

\*Power cord not included

- Includes rubberized push button or black button cover for iPad home button











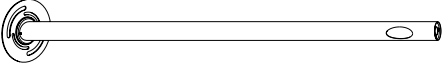





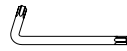
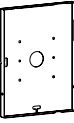
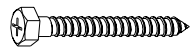
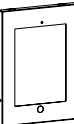

- Optional carry bag available:  
PAD12-02A-BAG

- iPad must be removed from face plate after use; storing iPad in the unit during transit is not recommended

- Packaged well in foam protective covering

- Unit cannot be shipped in molded case due to parts possibly getting scratched

**Parts Included:**

Part No. / Description	Qty	Part No. / Description	Qty
A  tube	1	M  M5x8(tamper-proof screw)	5
B  plastic cover	1	N  M6x20	3
C  washer	1	O  $\Phi 13.5 \times \Phi 5.5 \times 3.2$	2
D  base	1	P  TORX tool	1
E  rear cover	1	Q  ST6.3x55	3
F  front cover	1	R  concrete anchor	3
G  silicone pad(A)	2	S  turn-knob	1
H  silicone pad(B)	2	T  D5 washer	2
I  silicone pad(C)	1	U  5mm Allen key	1
J  silicone pad(D)	1	V  button	1
K  silicone pad(E)	1		
L  silicone pad(F)	1		

Parts B, C, G-N are packaged together in plastic bag

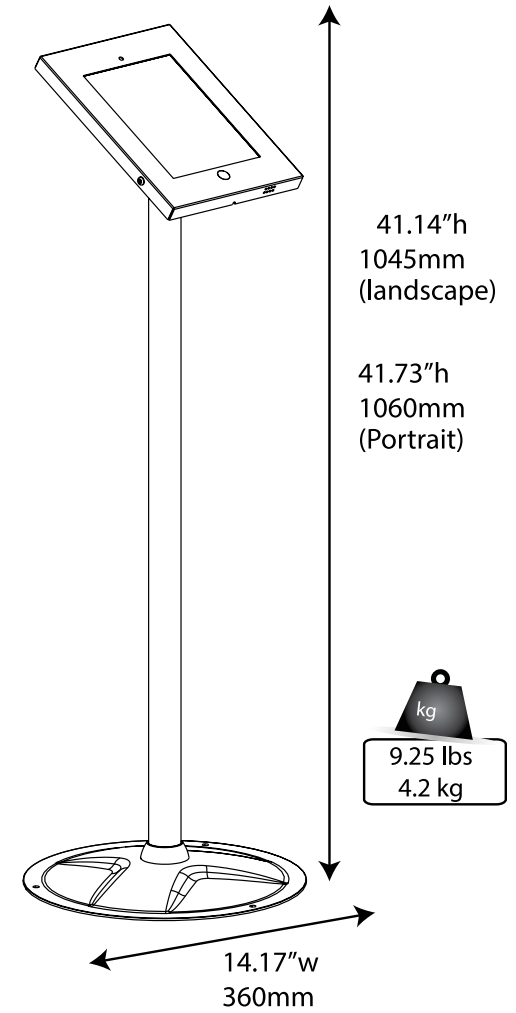

\*Optional upgrade bag shown above

**Set-up:**

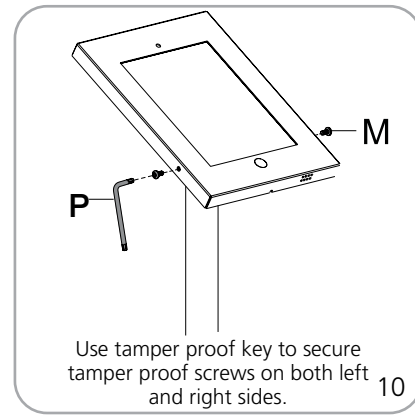
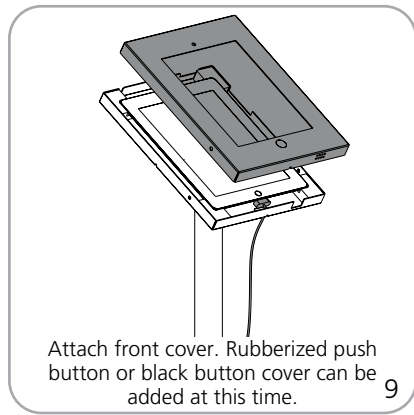
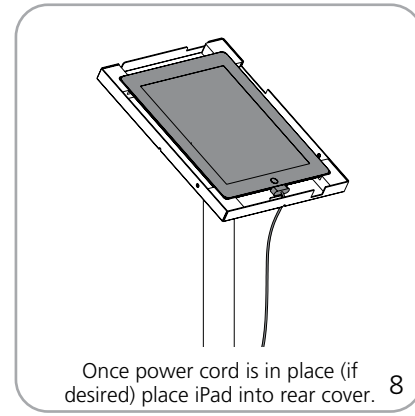
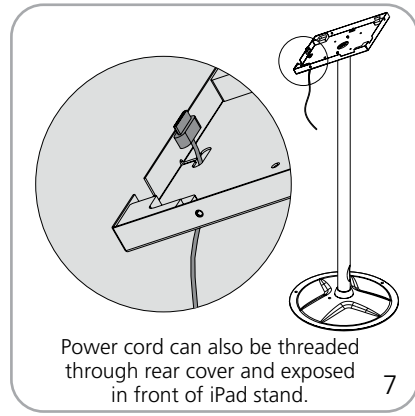
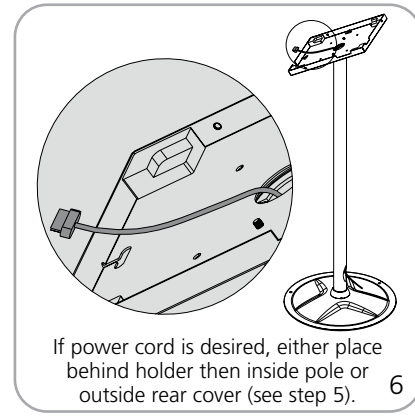
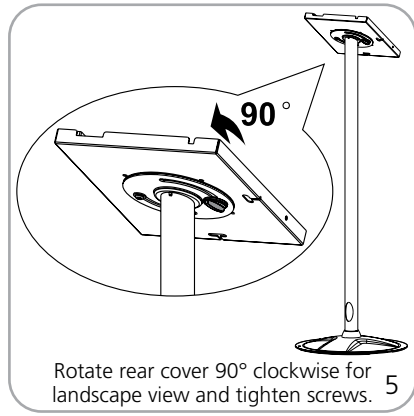
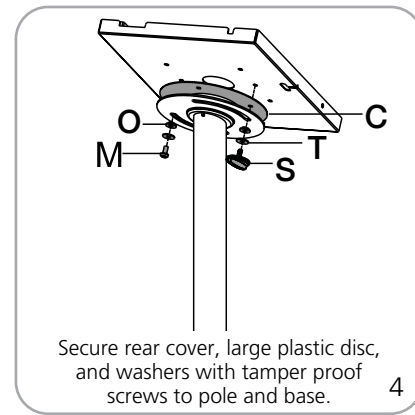
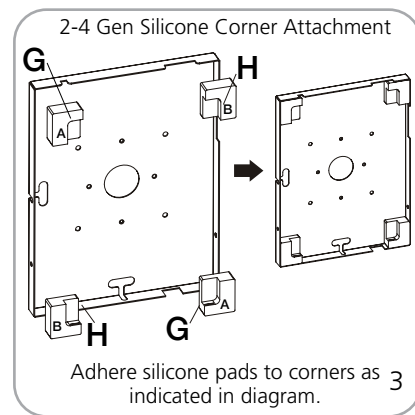
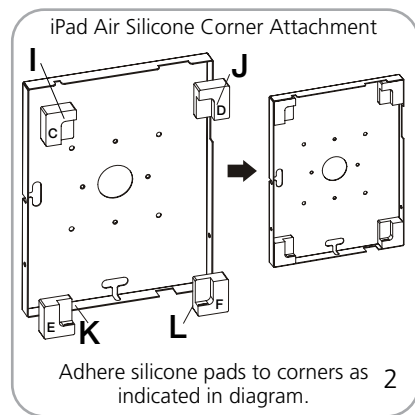
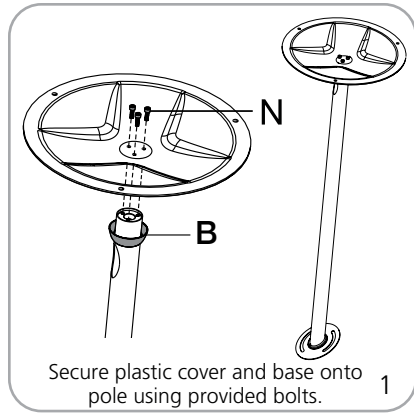

**Optional Base Attachment:**

